



## **NATIONAL HIGHWAYS AUTHORITY OF INDIA**

(MINISTRY OF ROAD TRANSPORT & HIGHWAYS, GOVT.OF INDIA)

Regional Office, Madurai  
Plot No. 3, Surya Towers, 2<sup>nd</sup> Floor,  
1<sup>st</sup> East Street, K.K. Nagar,  
Madurai - 625 020.

Consultancy Services for Supervision Consultant (SC) of Operation & Maintenance of 4 laning of Madurai - Tirunelveli - Panagudi - Kanniyakumari Section from Km 0/000 to Km 243/170 of NH-7 (New NH.44) including construction of Bridge at Narikulam Tank Portion at km 230/700 to Km 231/250 and Improvement of Approach Road to ROB at Km 0/600 at Samayanallur of NH-7(New NH.44) and Operation & Maintenance of Tuticorin - Tirunelveli Section from Km 0/000 to km 47/250 of NH-7A (New NH.138) in the State of Tamil Nadu.

*(Consultancy Package No. RO Madurai/SC/O&M/2017/Package-I)*

***(2<sup>nd</sup> Call)***

***January, 2018***

---

**CONTENTS**

<b>Particulars</b>	<b>Page Nos.</b>
SECTION 1. INFORMATION TO CONSULTANTS .....	(i-vi)
SECTION 2. LETTER OF INVITATION TO CONSULTANTS .....	7-25
SECTION 3. FORMATS FOR SUBMISSION OF FIRMS CREDENTIALS.....	26-29
SECTION 4. FORMAT FOR SUBMISSION OF TECHNICAL PROPOSAL .....	30- 62
SECTION 5. FORMAT FOR SUBMISSION OF FINANCIAL PROPOSAL. ....	63-70
SECTION 6. TERMS OF REFERENCE FOR SUPERVISION CONSULTANT .....	71-191
SECTION 7. DRAFT FORM OF CONTRACT .....	192-254

**REQUEST FOR PROPOSAL (RFP)****SECTION 1. INFORMATION TO CONSULTANTS**

**Sub: Supervision Consultant (SC) Services (2<sup>nd</sup> Call) for Operation & Maintenance of 4 laning of Madurai - Tirunelveli - Panagudi - Kanniyakumari Section from Km 0/000 to Km 243/170 of NH-7 (New NH.44) including construction of Bridge at Narikulam Tank Portion at km 230/700 to Km 231/250 and Improvement of Approach Road to ROB at Km 0/600 at Samayanallur of NH-7(New NH.44) and Operation & Maintenance of Tuticorin - Tirunelveli Section from Km 0/000 to km 47/250 of NH-7A (New NH.138) in the State of Tamil Nadu**

**GENERAL:-**

1. The National Highways Authority of India (NHAI) invites proposals for engaging a Supervision Consultant on the basis of International Competitive Bidding for the following contract package in the State of Tamil Nadu.

**Table : Details of Project**

S. No.	Consultancy Package	NH No.	State	Project Stretch	Project Length (Km) / Total Project Cost (Cr.)	Assignment period (months)
1	RO Madurai/SC/O&M/2017/Packag e-I (2 <sup>nd</sup> Call)	7 & 7A (New NH. 44 & 138)	Tamil Nadu	Operation & Maintenance of 4 laning of Madurai - Tirunelveli - Panagudi - Kanniyakumari Section from Km 0/000 to Km 243/170 of NH-7 (New NH.44) including construction of Bridge at Narikulam Tank Portion at km 230/700 to Km 231/250 and Improvement of Approach Road to ROB at Km 0/600 at Samayanallur of NH-7(New NH.44) and Operation & Maintenance of Tuticorin - Tirunelveli Section from Km 0/000 to km 47/250 of NH-7A (New NH.138) in the State of Tamil Nadu. (2 <sup>nd</sup> Call)		

The RFP shall be received through “INFRACON” ([www.infracon.nic.in](http://www.infracon.nic.in)) and will be evaluated based on details furnished on “INFRACON”. As such before submitting the proposal, the Consultant (the firm and all key personnel) shall mandatorily register and enlist themselves, on the MoRT&H portal “INFRACON” and upload all relevant information to enable correct evaluation of RFP.

All the bidders registered on “INFRACON” shall form a Team on “INFRACON” which would be assigned unique INFRACON Team ID. Bidders while submitting the RFP proposal shall furnish registration details including INFRACON Team ID. A copy of INFRACON Operation Procedure is enclosed for bidder’s reference.

2. Selection of SC shall be as per selection procedures given in the Model Contract Agreement and general procurement methods followed in NHAI. The selected SC shall be intimated to the Contractor
3. The proposal shall be submitted in English Language and all correspondence would be in the same language.
4. The Operation & Maintenance of project broadly include Operation and Maintenance activities of the Contractor for completed construction works and Projects Facilities are opened to traffic as per the Contract Agreements.
5. As per the Terms and Conditions of the Contract Agreement(s), the Supervision Consultant is broadly required to:
  - i. Survey (Including Traffic Survey) and examination of stretch for requirements of additional structures, project facilities, road furniture's and other items warranted for implementation including structural designs.
  - ii. Pavement condition survey for the entire stretch for the entire including plan and profile and working out required pavement strengthening measures and improvements.
  - iii. Condition survey of all existing structures and working out strengthening measures.
  - iv. Cost valuation of proposed items/works after conducting survey examination of complete stretch.
  - v. Preparation of RFP document
  - vi. Review of the Drawings and Documents;
  - vii. Review, inspection and monitoring of Construction Works;
  - viii. Conducting Tests on completion of construction and issuing Completion Certificate;
  - ix. Review, inspection and monitoring of O&M;
  - x. Review, inspection and monitoring of Divestment Requirements;
  - xi. Determining, as required under the Agreement, the costs of any works or services and/or their reasonableness;
  - xii. Determining, as required under the Agreement, the period or any extension thereof, for performing any duty or obligation;
  - xiii. Providing all requisite data on monthly basis in Monthly Progress Report (MPR) within a period of 7 days from the close of month, as required by Authority, for updating the project specific website and PMIS substantially in the format prescribed at Annexure-III
  - xiv. Assisting the Parties in resolution of disputes; and
  - xv. Undertaking all other duties and functions in accordance with the Contract Agreement.
  - xvi. Provide assistance in dispute resolution/arbitration case/court case pertain to the project highway even from the commencement of construction of the (4 lane) project.
  - xvii. To perform the function/duties as directed by the PIU/Authority for the project stretch without any additional cost.
6. The interested consultancy firms may download the RFP from NHAI Website 13.01.2018 to 08.02.2018 upto 10.00 hrs. The Consultant who download the RFP document from the website will be required to pay the non- refundable fee of Rs.5,000/- at the time of the

submission of the Bid proposal. The RFP will be invited through e- tendering portal. Refer Procedure under e-tendering for submission of RFP through e- tendering.

7. In this document, unless the context otherwise requires, reference to a firm or consultant or bidder or applicant shall be construed as reference to any individual firm, organization, company or their JV, reputed engineering institutions such as IITs/NITs/Deemed Universities.
8. The proposal should be submitted by consultancy firms in two parts in two separate envelopes/package duly marked and put together in one single outer envelope/package. The two parts of the proposal are Part 1: Technical Proposal and Part 2: Financial Proposal. For a given Project, Stage-1 of the Evaluation shall consider the evaluation of the Technical Proposal (i.e. Part 1). The firm scoring the qualifying marks (minimum 75%) as mentioned in RFP shall be listed in the descending order of their technical score and 5 top ranking firms shall only be considered for further evaluation provided none of them is in conflict of interest with the Contractor. The firms in conflict of interest shall be substituted by next ranking firm not having conflict of interest with the Contractor. Under stage 2, the financial proposal of such five firms as selected above shall be opened and evaluated. The weightage of Technical and Financial score shall be 80% & 20% respectively. The final selection of the firm shall be based on the highest combined score of Technical and Financial Proposal.
9. The total time period for the assignment as Supervision Consultant will be for 36 months. On expiry or termination of aforesaid period, the Authority may in its discretion renew the appointment.
10. Consultants may apply either as a sole firm or forming Joint Venture with other consultants. In case of Joint Venture, the maximum number of Joint Venture partners is limited to 2 (i.e. one lead + 1 JV partners). Formulation of more than one JV with different partners for the same work is not allowed and all such proposal involving the firms shall be treated as non-responsive.
11. (A) The Applicant whether a sole applicant or lead member with joint venture may include any number of Associate to provide technology in the assignment (Ref para 9 (iii) of Data Sheet). The associate firm can provide equipment based road inspection services for any of the 5 equipment viz., (i) Network Survey Vehicle including all modules required as per technical specifications, (ii) Falling Weight Deflectometer, (iii) Mobile Bridge Inspection Unit and (iv) Retro Reflectometer (v) Automatic Traffic Counter cum Classifier (ATCC). However, the associate(s) cannot be common for 2 or more bidders. If any associate is common with 2 or more bidders, all those bids shall be declared non-responsive. Hence, the bidder may ensure on his own that the associate proposed by him is not proposed by any other bidder participating in the same assignment and the bidder is solely responsible in this regard.  
  
(B) In addition, the applicant whether a sole applicant or lead member with joint venture may also include an Associate for providing key personnel. In such case, the applicant should submit a MOU with associate regarding role and responsibility

of Associate Company. However the maximum no. of key personnel from Associate firm during RFP proposal and implementation of contract should be limited to two (2).

12. Consulting firms meeting the following criteria and not in conflict of interest with the Contractor are only eligible for applying for this assignment. Firms not meeting these criteria need not apply.

A. Eligibility criteria for sole applicant.

S. No.	Experience of the applicant in completed projects in last seven years		Annual Turnover*
	Preparation of DPR (NH/SH/Equivalent)	Project Supervision/IC (NH/SH/Equivalent)	
1.	The firm should have prepared DPR/FS cum PPR for at least Two projects of 4/6 laning** of 30% of project length each or one project of 4/6 laning of 50% of project length.	The firm should have experience of Project Supervision/IE of a. At least two construction projects of four/six laning** of 30% of project length each or one project of 4/6 laning of 50% of project length and At least one O&M project under DBFOT/OMT/ O & M of four/six laning** of 50% of project length.	Annual turnover (average of last 5 years or in each of the preceding two years) of the firm from consultancy business should be equal to or more than Rs.2.5 Crore.

\* Annual Turnover should be duly certified by statutory body like Chartered Accountant or Independent Auditors who are competent to do so as recognized by the State concerned.

- B. Eligibility Criteria for partners in case of JV (not more than 1 JV partner shall be allowed).

Lead Partner should meet at least 75% and JV partner should meet at least 40% eligibility criteria of Annual Turnover. Lead partner and the JV partner both shall have experience of at least one project of eligible category as in para 12 (A) above

Note: The weightage given for experience of a firm would depend on the role of the firm in the respective assignments. The firm's experience would get full credit if it was the sole firm in the respective assignment. Experience weightage for firms joining Lead partner JV partner shall be considered in the same proportion as payment has been received \*\* by the firm towards consultancy work in the project.

\*\*For weightage of experience in any past Consultancy assignment experience certificate from the client shall be accepted. In the absence of experience

*certificate from the client, proportion of payment received towards Consultancy work duly certified by statutory body like Chartered Accountant or Independent Auditors who are competent to do so as recognised by the State concerned shall be accepted. Annual turnover duly certified by Chartered Accountant shall be accepted. In case of non-availability of such documents no weightage of turnover/experience will be considered.*

13. Following enhancement factor will be used for the cost of services provided and for the turnover from consultancy business to a common base value for works completed in India:

<b>Year of completion of services / turnover</b>	<b>Enhancement factor</b>
Financial year in which RFP invited	1.00
One year prior to RFP	1.10
Two year prior to RFP	1.21
Three year prior to RFP	1.33
Four year prior to RFP	1.46
Five year prior to RFP	1.61

Applicant should indicate actual figures of costs and amount for the works executed by them without accounting for the above mentioned factors.

In case the financial figures and values of services provided are in foreign currency, the above enhancement factors will not be applied. Instead, current market exchange rate (State Bank of India BC Selling rate as on last date of submission of the bid) will be applied for the purpose of conversion of amount in foreign currency into Indian Rupees.

14. The Bidder including individual or any of its Joint Venture Member should, in the last 2 years, have neither failed to perform for the works of Expressways, National Highways, ISC (Inter State Connectivity) & EI (Economic Importance) works, as evidenced by imposition of a penalty by an arbitral or judicial authority or a judicial pronouncement or arbitration award against the Bidder including individual or any of its Joint Venture Member, as the case may be, nor has been expelled or terminated by Ministry of Road Transport & Highways or its implementing agencies for breach by such Bidder including individual or any of its Joint Venture Member. Consultants (sole firm or lead firm and any of the JV partners) who have been debarred by NHAI and the debarment is in force as on date of application, need not apply as their RFP proposal will not be entertained.
15. NHAI will not be responsible for any delay, loss or non-receipt of RFP document sent by post/courier. Further, NHAI shall not be responsible for any delay in receiving the Proposal and reserves the right to accept/reject any or all applications without assigning any reason thereof.
16. The Technical proposal (in Original) must be submitted in a hard bound form with all pages numbered serially, along with an index of submission. (Hard bound implies binding

between two covers through stitching or otherwise whereby it may not be possible to replace any paper without disturbing the documents). Spiral bound form, loose form, etc. will be not accepted. A copy of the Technical Proposal should also be uploaded on the e-portal. Financial Proposals shall have to be submitted only in Electronic Form (to be uploaded on the e-portal). In the event, any of the instructions mentioned herein have not been adhered to, NHAI may reject the Proposal

17. NHAI will be at liberty to keep the credentials submitted by the Consultants at bidding stage, in public domain and the same may be uploaded on NHAI web-site. By submitting the proposal, the Consultants shall be deemed to have no objection to upload/hoist the information pertaining to their credentials as well as of their key personnel on NHAI web-site.
18. The individual key personnel proposed in the bid by the consultants or any replacement thereof should undertake that they shall have no objection in uploading/hoisting of their credentials by NHAI in public domain
19. RFP submission must be received not later than **12.00 hrs on 09.02.2018** in the manner specified in the RFP document at the address given below.

**General Manager (Tech) & Regional Officer,  
National Highways Authority of India  
Plot No. 3, Surya Towers,  
2<sup>nd</sup> Floor, 1<sup>st</sup> East Street,  
K.K Nagar,  
Madurai - 625 020.  
Tamil Nadu.**

## SECTION 2. LETTER OF INVITATION TO CONSULTANTS

### 1. INTRODUCTION

- 1.1 Bids are invited from consulting firms either as a sole firm/ joint venture with other consultant willing to act as SC to submit a proposal for providing consulting services required for the assignment named in the attached Letter of Invitation.
- 1.2 A brief description of the assignment and its objectives are given in the Terms of Reference (TOR).
- 1.3 This RFP is neither an agreement nor an offer by the Authority to the prospective Applicants or any other person. The purpose of this RFP is to provide interested parties with information that may be useful to them in the formulation of their Proposals pursuant to this RFP. This RFP includes statements and assumptions, which reflect various assessments arrived at by the Authority in relation to the Consultancy. Such assessments and statements do not purport to contain all the information that each Applicant may require. The information contained in this RFP, may not be complete, accurate, adequate or correct. Each Applicant should, therefore, conduct its own investigations about the assignment and the local conditions before submitting the proposal by paying a visit to the Client and the project site, sending written queries to the client, before the date and time specified in the Data Sheet.
- 1.4 Please note that (i) the costs of preparing the proposal, including visits to site, are not reimbursable as a direct cost of assignment and (ii)NHAI is not bound to accept any of the proposals received by it and reserves the right to annul the selection process at any time prior to contract award, without thereby incurring any liability to the Consultants.
- 1.5 We wish to remind you that in order to avoid conflict of interest situations, any firm associated with the Contractor of the Project Highway as its Design and/or Supervision Consultant during construction period and defect liability period of the project or previous Operation and Maintenance period and/or the Contractor(s) as Design Consultant and/or Construction Supervision Consultant is not eligible to participate in the bidding. The restriction herein shall not apply after a period of 5(five) years from the completion of their consultancy assignment
- 1.6 Those Consultants who were engaged by Ministry/ NHAI for the above project as Design Consultants for preparation of Detail Project Reports shall not be permitted to submit proposal for providing the consultancy services as Independent Consultant for the same project for first Operation and Maintenance period of the project either individually or in JV with other firms. The restriction herein shall not apply after a period of 5 (five) years from the completion of their DPR consultancy assignment for the project.

- 1.7 The Consultant will not propose any personnel who had been engaged by the Contractor on the same project within last one year.
- 1.8 Consultant have an obligation to disclose any situation of actual or potential conflict that impacts their capacity to serve the best interest of their Client, or than may reasonably be perceived as having this effect. Failure to disclose said situations may lead to the disqualification of the Consultant or the termination of its Contract and/or any other action as deemed fit by the Authority at any stage.
- 1.9 It is the NHA's policy that the consultants observe the highest standard of ethics during the selection and execution of such contracts. In pursuance of this policy, the NHA:
  - i. Defines, for the purpose of this paragraph, the terms set forth below as follows:
    - a "corrupt practice" means the offering, giving, receiving, or soliciting, directly or indirectly, of anything of value to influence the action of a public official in the selection process or in contract execution;
    - b "fraudulent practice" means a misrepresentation or omission of facts in order to influence a selection process or the execution of a contract;
    - c "collusive practices" means a scheme or arrangement between two or more consultants with or without the knowledge of the Client, designed to establish prices at artificial, non-competitive levels;
    - d "coercive practices" means harming or threatening to harm, directly or indirectly, persons or their property to influence their participation in a procurement process, or affect the execution of a contract.
  - ii. Will reject a proposal for award if it determines that the Consultant recommended for award has, directly or through an agent, engaged in corrupt, fraudulent, collusive or coercive practices in competing for the contract in question;
  - iii. Will declare a firm ineligible, either indefinitely or for a stated period of time, to be awarded a contract if it at any time determines that the firm has engaged in corrupt or fraudulent practices in competing for, or in executing, a contract; and
  - iv. Will have the right to require that a provision be included requiring consultants to permit the NHA to inspect their accounts and records relating to the performance of the contract and to have them audited by authorized representatives of NHA.
- 1.10 Consultants, their Sub-Consultants, and their associates shall not be under a declaration of ineligibility for corrupt and fraudulent practices. Furthermore, the Consultants shall be aware of the provisions on fraud and corruption stated in the specific clauses in the General Conditions of Contract.

Consultants shall furnish information on commissions and gratuities, if any, paid or to be paid to agents relating to this proposal and during execution of the assignment if the Consultant is awarded the Contract, in the Financial Proposal.

- 1.11. The Data Sheet indicates how long Consultants' Proposals must remain valid after the submission date. During this period, Consultants shall maintain the availability of Professional staff nominated in the Proposal. The Client will make its best effort to complete the process within this period. Should the need arise, however, the Client may request Consultants to extend the validity period of their proposals. Consultants who agree to such extension shall confirm that they maintain the availability of the Professional staff nominated in the Proposal, or in their confirmation of extension of validity of the Proposal, Consultants could submit new staff in replacement. If any consultant seeks any replacement(s), while extending the bid validity, then the same shall be evaluated for ascertaining suitability of replacement as per the provisions of the RFP and no remuneration shall be deducted for any such replacement(s). However, the technical evaluation shall take into account of the originally submitted CV(s) only irrespective of replacement sought. Consultants who do not agree have the right to refuse to extend the validity of their Proposals.

## **2. CLARIFICATIONS AND AMENDMENT OF RFP DOCUMENTS**

- 2.1. The Consultants may request a clarification of any of the RFP documents up to the number of days indicated in the Data Sheet before the Proposal submission date. Any request for clarification must be sent in writing by paper mail, facsimile, or electronic mail to the Client's address indicated in the Data Sheet. The Client will respond by cable, facsimile, or electronic mail to such requests and will send copies of the response (including an explanation of the query but without identifying the source of inquiry) to all consultants who have purchased the RFP document. Clarification/amendment will also be hosted on NHA web-site.
- 2.2. At any time before the submission of Proposals, the Client may for any reason, whether at its own initiative or in response to a clarification requested by a Consulting firm, modify the RFP documents by amendment. Any amendment shall be issued in writing through addendum. Addendum may be sent by mail, cable, telex, facsimile or electronic mail to consultants or/and will be hosted on NHA website which will be binding on them. The Client may at its discretion extend the deadline for the submission of Proposals.

## **3. PREPARATION OF PROPOSAL**

- 3.1 You are requested to submit your proposal in Two Parts strictly using the formats enclosed herewith (refer section 3 and 4). The two parts shall be:

**Part 1: Technical Proposal and**

**Part 2: Financial Proposal.**

The Technical Proposal (Hard Bound) should be enclosed in an envelope which should be marked as “Part - 1 - Technical Proposal”. The Financial Proposal should be submitted only in Electronic Form. No hard copy of the Financial Proposal is to be submitted. Please also refer “procedure under e-tendering” defined in the RFP in this regard. The proposal shall be written in the English language as specified in the Data Sheet. All pages of the Proposal shall be signed by an authorized representative. The representative’s authorization shall be confirmed by written Power of Attorney duly notarized to be submitted with the proposal. In case of JV a MoU indicating the specific Projects, input and role of each Partner etc. shall be submitted with the proposal.

**Part 1: Technical Proposal**

- 3.2 You are expected to examine all terms and conditions included in the documents. Failure to act or to provide all requested information will be at your own risk and may result in rejection of your proposal.
- 3.3 During preparation of the Technical proposal you may give particular attention to the following:
- i. The man-months for the assignment shall be that stated in the Terms of Reference. The same shall be considered for the purpose of evaluation as well as award.
  - ii. The Consultants should prefer to field as many of their permanent staff as possible and higher marks shall be given in this regard. The permanent staff would be considered those already employed with the firm prior to one year from the month during which this Tender Notice is issued. More weightage will be given to those key personnel who are employed with more years with the firm.
  - iii. No alternative to key professional staff may be proposed and only one Curriculum Vitae (CV) may be submitted for each position and
  - iv. A good working knowledge of the language specified in the data sheet is essential for key professional staff on this assignment. Reports must be in the language (s) specified in the data sheet.
  - v. For Key Personnel e.g. Team Leader, Highway Maintenance cum Resident Engineer, Bridge/ Structural Engineer and Road Safety Expert, the Consultants should prefer candidates having worked on EPC Projects. Such personnel shall be rated higher than the candidates having no such experience at all”.
- 3.4 Your Technical Proposal must provide the following information, using but not limited to the formats attached in the Section 3 & 4.

- i) A brief description of the firm's organisation and an outline of recent experience of the Consultants and, in the case of Joint Venture, for each partner, on assignments of a similar nature. The information which you shall provide on each assignment should indicate, *inter-alia*, the profiles of the staff provided, duration, contract amount and firm's involvement. ***The details of assignments on hand shall also be furnished.***
- ii) Site Appreciation: limited to four A4 size pages in 1.5 space and 12 font including photographs, if any;
- iii) Proposed methodology for the execution of the services illustrated with bar charts of activities. The proposed methodology should be accompanied by the consultants initial view, key challenges they foresee and potential solutions. The proposal shall indicate as to whether the firm is having the facilities for carrying out the following field activities or these are proposed to be outsourced to specialized agencies.
  - Surface defects detection and roughness measurement using Network Survey Vehicle
  - Pavement strength measurement using FWD
  - Bridge inspection using Mobile Bridge Inspection Unit
  - Road signs inspection using Retro Reflectometer
  - Traffic count using Automatic Traffic Counter cum Classifier (ATCC)
- iv) Proposed Quality Audit Methodology including Quality Assurance Plan
- v) In case the consultant envisages outsourcing any or all of the above services to the expert agencies, the details of the same indicating the arrangement made with the agencies need to be furnished. These agencies would however, be subject to approval of the client to ensure quality input by such agencies before award of the work. For out-sourced services, proposed firms/consultants should have such experience on similar projects.
- vi) The composition of the proposed staff team, the tasks which shall be assigned to each and their timing;
- vii) Requirement for submission of CVs.
  - a. CVs strictly in the prescribed format and recently signed in blue ink on each page by both the proposed professional staff and the Managing Director/Head or the authorized representative of the firm.
  - b. Key information should include years with the firm and degree of responsibility held in various assignments. In CV format, at summary, the

individual shall declare his qualification & total experience (in years) against the requirements specified in TOR for the position (Ref. Enclosure-B of TOR). If any information is found incorrect, at any stage, action including termination and debarment from future NHAI projects upto 2 years may be taken by NHAI on the personnel and the Firm.

- c. If same CV is submitted by two or more firms, zero marks shall be given for such CV.
- d. CVs of Key Personnel having intermittent inputs will be considered only if the assignments on hand, including those for which LOA has been received from the Client or for which Consultant has been declared as H1, do not exceed 3(three)for team leader, 2 (two) for Road Safety Expert and 3(three) for bridge/structural engineer as on 7 days before due date of proposal.
- e. All the CVs which are to be evaluated should be complete in all respects including signing and certification by the individual and the firm. In order to overcome the difficulties in furnishing the duly signed CVs due to time prescribed for submission for RFP, maximum 3 CVs (except Team Leader and Highway Maintenance Engineer) with scanned signatures of the candidates on all pages shall be permitted. However, the authorized representative of the firm shall sign on each page. If the firm is selected, then the firm shall submit duly signed CVs before the signing of contract.
- f. If a CV score less than 75% marks, whatever marks it score will be carried forward for maximum 2 nos. key personnel for determining the total score of the firm. However, if the Key Personnel does not fulfil the minimum academic qualification (as mentioned at Enclosure-B of TOR of RFP), the overall score of his CV will be evaluated as zero. If the Key Personnel does not fulfil the minimum qualification related to experience (as mentioned at Enclosure-B of TOR of RFP), then zero marks will only be assigned for that sub criteria, but the marks obtained by the CV of the Key Personnel will be carried forward for maximum 2 nos. key personnel for determining the total score of the firm. In case, a firm is H-1, then maximum 2 (two) such Key Personnel (whose CV scores less than 75% or who does not fulfil the minimum qualification) will have to be replaced by the firm before signing the contract. The reduction in remuneration of such replacements will be at the rate of 10% for each replacement. In case CV of a person is turned out to be fake/incorrect/inflated during the assignment, the consultancy firms shall have to refund the salary and perks drawn including interest @12% per annum in respect of the person apart from other consequences. In addition to above, 10% of the salary and perks to be refunded shall be recovered from the Firm as penalty.

- viii) Deployment Schedule for each key personnel should be formulated and incorporated in the Technical Proposal which will be reviewed on quarterly basis.
- ix) Estimates of the total time effort (person x months) to be provided for the services, supported by bar chart diagrams showing the time proposed (person x months) for each professional staff and sub professional staff.
- x) A certification to the effect should be furnished by the Consultant that they have checked the qualifications and experiences details submitted by the key personnel in their CVs and found to be correct. This certification should be made in CVs of all key personnel after the certification by the candidate. The format of CV includes certification to this effect.
- xi) Detailed Evaluation criteria of the Firm and Key Personnel, which will be used for evaluation of Technical Bids is enclosed as Appendix B10 to Section-4. The consultants shall submit the self-evaluation as per Appendix B10 duly filled in based on the Detailed Evaluation criteria mentioned therein at Appendix-B10. While submitting the self-evaluation, Consultant shall make reference to the documents along with page nos., which have been relied upon in his self-evaluation.

3.5 The technical proposal must not include any financial information.

## Part 2: Financial Proposal

- 3.6 Your Financial Proposal must be strictly using the formats attached in Section 5. No additional items/quantities other than that specified in the formats should be proposed by the Consultants since the same shall not be considered for the evaluation/award. For the first 12 months from the Date of Commencement of Services, Consultants shall be paid billing rates as indicated above. Beginning 13<sup>th</sup> months of the services provided, billing rates shall be increased on all items of contract inter alia including vehicle hire, office rent, consumables, furniture etc @ 5% every 12 months for local currency for the subsequent period of services rendered by the personnel of all categories namely (i) key Personnel; (ii) sub-Professional personnel and (iii) Support staff. However, for evaluation and award of the Bid proposals, the quoted initial rate (as applicable for first 12 months) shall be multiplied by the total time input for each position on this contract, i.e. without considering the increase in the billing rates.
- 3.7 The Financial Proposal should clearly identify as a separate amount, the local taxes (including social security), duties, fees, levies and other charges imposed under the applicable law, on the consultants, the sub-consultants, and their personnel (other than nationals or permanent residents of the government's country); unless the Data Sheet specifies otherwise. This cost, however, will not be considered in evaluation.

3.8 Consultants may express the price of their services in the Local currency (Indian Rupees)

3.9 The Goods and service tax shall be considered for release along with invoice, subject to condition that Consultant submits the proof of deposit of the same with a Certificate from CA firm within a period of 90 days of receipt of such Goods and service tax.

\*(This will be the exchange rates as per Reserve Bank of India rounded off to nearest Rupee applicable at the time of RFP invitation).

#### 4. SUBMISSION, RECEIPT AND OPENING OF PROPOSALS

##### 4.1. PREPARATION & SUBMISSION OF APPLICATIONS:

The Applicants shall submit the proposal (Proof of Eligibility and Technical Proposal) in hard bound form with all pages numbered serially and by giving an index of submissions. Applications submitted in other forms like spiral bound form; loose form etc. shall be rejected. Copies of Applications shall not be submitted and considered.

Financial proposal are only to be submitted online and no hard copy of the financial proposal should be submitted.

- i. Detailed RFP may be downloaded from <https://etenders.gov.in> and the Application may be submitted online following the instructions appearing on the screen. A Vendor manual containing the detailed guidelines for e-tendering system is also available on <https://etenders.gov.in>.
- ii. The following shall be the form of various documents in the Application:

##### **A. Only Electronic Form (to be uploaded on the <https://etenders.gov.in>)**

- a. Technical proposal as indicated in para 'B' below
- b. Financial proposal as per format prescribed in SECTION-5 OF RFP.

##### **B. Hard copy of Technical proposal in Original to be submitted in Sealed Envelope and also in Electronic form to be uploaded on the <https://etenders.gov.in>**

- (I) Technical Proposal in Hard Bound Form including
  - a. Power of Attorney for signing the Application
  - b. If applicable, the Power of Attorney for Lead Member of JV;
  - c. Copy of Memorandum of Understanding between JV partners, if applicable;
  - d. Copy of Memorandum of Understanding with Associate, if applicable
  - e. Firm's credentials as per format prescribed in SECTION-3 OF RFP.
  - f. Technical Proposal as per format prescribed in SECTION-4 OF RFP.

- (II) Demand Draft (DD) of Rs.5,000/- (Rupees Five thousand only)towards the cost of RFP in favor of National Highways Authority of India.
- iii. The Applicant shall submit the original documents specified above in point no. 4.1(ii)B together with their respective enclosures and seal it in an envelope and mark the envelope as “Technical Proposal” for the Project for which proposal is submitted and name and address of the Applicant. The envelope must be clearly marked “DO NOT OPEN, EXCEPT IN THE PRESENCE OF THE EVALUATION COMMITTEE”. In addition, the Application due date should be indicated on the right hand corner of the envelope. The original documents should be submitted before 12:00 hours Indian Standard Time on the Application due date i.e. on 09.02.2018, at the below mentioned address in the manner and form as detailed in the RFP. A receipt thereof should be obtained from the below mentioned person.

General Manager (Tech) & Regional Officer,  
National Highways Authority of India  
Plot No. 3, Surya Towers,  
2<sup>nd</sup> Floor, 1<sup>st</sup> East Street,  
K.K Nagar,  
Madurai - 625 020.  
Tamil Nadu.  
Tel. No. 0452 2587750  
Fax No. 044 - 2587750  
E mail: [nhairomadurai@gmail.com](mailto:nhairomadurai@gmail.com)

- The Applicant shall upload scanned copies of the Technical Proposal and Financial Proposal as specified in point nos. 4.1 (ii) A & B above on the <https://etenders.gov.in> before 12:00 hours Indian Standard Time on the Application due date i.e. on 08.02.2018. Hard copy of the documents as specified in point nos. 4.1 (ii) B above only is required to be submitted. Financial Proposal is to be submitted On-line only and no hard submission is to be made. In the event of any discrepancy between the original and the copy (in electronic form), the original shall prevail.
- iv. It may be noted that the scanned copies can be prepared in file format i.e. PDF and/or ZIP only. The Applicants can upload a single file of size of 10 MB only but can upload multiple files.
- C. Procurement of Consultants through INFRACON Portal (to be uploaded on [www.infracon.nic.in](http://www.infracon.nic.in))**
- i) All the Consultancy Firms and key personnel have to register on [www.infracon.nic.in](http://www.infracon.nic.in) portal and should upload their technical proposals / credentials in public domain. This Portal has facility to host Firms & Personnel credentials online with option to link to Aadhaar & Digi locker for data validation & purity.

- ii) The Applicant shall ensure that they have uploaded modules stipulated in MoRT&HCircular No.RW-NH-35075/1/2010-S&R dt. 28.10.2015 on [www.infracon.nic.in](http://www.infracon.nic.in), failing which the bid submitted will be summarily rejected. Hard copy of the documents as specified in the said MoRT&H Circular only is required to be submitted. Financial Proposal is to be submitted online only and no hard copy submission is to be made. In the event of any discrepancy between the original and the copy (in electronic form), the original shall prevail.

#### **4.2. Modification / Substitution/ Withdrawal of bids:**

- i. The Bidder may modify, substitute or withdraw its e- bid after submission. Prior to the Bid Due Date. No Bid shall be modified, substituted or withdrawn by the Bidder on or after the Bid Due Date.
- ii. Any alteration/ modification in the Bid or additional information supplied subsequent to the Bid Due Date, unless the same has been expressly sought for by the Authority, shall be disregarded.
- iii. For modification of e-bid, bidder has to detach its old bid from e-tendering portal and upload / resubmit digitally signed modified bid.
- iv. For withdrawal of bid, bidder has to click on withdrawal icon at e-tendering portal and can withdraw its e-bid.
- v. Before withdrawal of a bid, it may specifically be noted that after withdrawal of a bid for any reason, bidder cannot re-submit e-bid again.

#### **4.3. OPENING AND EVALUATION OF APPLICATIONS:**

Opening of Proposals will be done through online for Financial Proposal and both on-line and manually for Technical Proposal.

- i. For participating in the tender, the authorized signatory holding Power of Attorney shall be the Digital Signatory. In case the authorized signatory holding Power of Attorney and Digital Signatory are not the same, the bid shall be considered non- responsive.

The Authority shall open Envelope containing Technical Proposal received as mentioned in point nos. 4.1 (ii) B at 15:00 hours Indian Standard Time on the Application due date i.e. on 09.02.2018, in the presence of the Applicants who choose to attend. This Authority will subsequently open the Technical Proposal as mentioned in point no.4.1A(a) above and evaluate the Applications in accordance with the provisions set out in the RFP.

- ii. The Financial Proposal 4.1 (ii) A (b) will be opened of the short listed applicants who qualify for financial opening as per RFP. The date of opening of Financial Proposal will be notified later on.

## 5. PROPOSAL EVALUATION

5.1. A two -stage procedure shall be adopted for evaluating the proposals.

5.2. Deleted.

### Technical Proposal

5.3.

- i. The Evaluation Committee appointed by the NHAI shall carry out its evaluation applying the evaluation criteria at Appendix-B10 and point system specified in the data sheet. Each responsive proposal shall be attributed a technical score (St.) The technical proposal should score at least 75 points to be considered responsive. The Authority shall shortlist 5 (five) top firms on the basis of their technical score not in the conflict of interest with the contractor.
- ii. The Technical Evaluation made by NHAI based on the criteria at Appendix-B10 will be made available on NHAI website i.e. [www.nhai.org](http://www.nhai.org), giving opportunities to respond within 7 days in case of objections, if any.

### Financial Proposal

- 5.4. After the evaluation of Technical Proposals is completed and the shortlist of 5 firms is finalized, NHAI may notify those consultants whose proposals were not considered as per conditions of RFP indicating that their Financial Proposal will not be opened online. The NHAI shall simultaneously notify the finally selected 05 (five) short listed firms indicating the date and time set for opening of the Financial Proposals.
- 5.5. The Financial Proposals shall be opened through e-proc publicly in the presence of the consultants' representatives who choose to attend. The name of the consultant, the technical scores, and the proposed prices shall be read aloud and recorded when the Financial Proposals are opened. The Client shall prepare minutes of the public opening.
- 5.6. The Evaluation Committee will determine whether the submitted Financial Proposals are complete (i.e. whether they have included cost of all items of the corresponding proposals; if not, then the cost towards such missing items will be considered as NIL, but the Consultant shall, however, be required to carry out such obligations without any additional compensation. In case under such circumstances, if Client feels that the work cannot be carried out within the overall cost as per the submitted financial proposal, such proposals shall be considered non responsive.
- 5.7. The Evaluation Committee shall determine if the financial proposal is complete and without computational errors. The order of priority as among these firms on the basis of financial bids will also be determined and the lowest financial bid shall rank first for award of contract.

- 5.8. The lowest Financial Proposal (Fm) will be given a financial score (Sf) of 100 points. The financial scores (Sf) of the other Financial Proposals will be computed as

$S_f = 100 \times F_m / F$ , where  $S_f$  is the financial score.  $F_m$  is the lowest price and  $F$ , the price of the proposal under consideration. Proposals shall finally be ranked according to their combined technical ( $S_t$ ) and financial ( $S_f$ ) scores using the weights indicated in the data sheet:

$$S = S_t \times T\% + S_f \times P\%.$$

The Firm achieving the highest combined technical financial score shall be declared as the most preferred bidder.

## 6. Replacement of Personnel

- 6.1. Prior to the expiration period of validity of proposal, the NHAI shall notify the successful firm (first ranking firm) in writing by registered letter or facsimile and issue LOA. In case two or more firms offer same lowest financial bid, the firm achieving the highest Technical score shall be considered for LOA.
- 6.2. The proposal shall include methodology (work plan), staffing and bar charts, which shall indicate activities, staff, periods in the field and in the home office, staff months, logistics and reporting. Special attention shall be paid to optimise the required outputs from the firm within the available budget and to define clearly the inputs required from the NHAI to ensure satisfactory implementation of the assignment.
- 6.3. It is the responsibility of the Consultant, before submitting the financial proposal, to contact the local tax authorities to determine the local tax amount to be paid by the Consultant under the Contract. Having selected a firm, among other things, on the basis of an evaluation of proposed key professional staff, the Contract will be finalized.
- 6.4 All replacements shall be governed by Clause 4.5 ( Renewal and/or Replacements of Personnel) of General Condition of the Contract.

## 7. AWARD OF CONTRACT

- 7.1. The Client shall award the Contract to the selected Consultant. However, after signing of the Contract, the Client may return the unopened Financial Proposals to the unsuccessful Consultants.
- 7.2. The successful firm with whom the contract is signed is expected to commence the assignment on the date and at the location specified in the data sheet.

## 8. PERFORMANCE CLAUSE

Supervision Consultant shall be expected to fully comply with all the provisions of the 'Terms of Reference', and shall be fully responsible for supervising and ensuring that the Designs, Construction and Maintenance and Operation of the facility takes place in accordance with the provisions of the Contract Agreement. Failure of the Supervision Consultant to notifying NHAI and the Contractor on non-compliance of the provisions of the Contract Agreement by the Contractor, non-adherence to the provision of ToR and non-adherence to the time schedule prescribed under ToR shall amount to non-performance.

The Supervision Consultant shall appoint senior most technical director or equivalent as its authorised representative, who shall correspond with the NHAI besides Team Leader to monitor the performance of its staff, undertake quarterly site inspections and give a report to NHAI on such inspection for comments and suggestions of NHAI for future compliance. The proposal submitted shall also include the name of the authorised representative along with the authorization letter and power of attorney. No separate payment shall be made for such inputs and site visits of the authorized representative as the same shall be treated as incidental to the assignment.

## 9. CONSULTANT'S PROPOSAL

- 9.1. Broad job-description and minimum qualification and experience requirements for key personnel mentioned above are given in Enclosure-B. However, higher marks shall be accorded to the Candidate with higher relevant qualification and experience in EPC projects. The age of the Key Personnel should not be more than 65 years on the date of submission of proposal. Consultants are advised in their own interest to frame the technical proposal in an objective manner as far as possible so that these could be properly assessed in respect of points to be given as part of evaluation criteria. The bio-data of the key personnel should be signed on every sheet by the personnel concerned and the last sheet of each bio-data should also be signed by the authorised signatory for the Consultant. The key personnel shall also certify at the end of their bio-data proforma that they have not left any of the NHAI works without completing of their assignment and have not accepted any other offer at the time of signing of the bio-data and as such shall be available to work with the Supervision Consultant, if the Project is awarded. In case the key personnel leaves the assignment without approval of NHAI, NHAI would be at liberty to take any appropriate action against that key personnel including debarment.
- 9.2. In addition to above, the consultants are required to propose sub-professional staff as detailed in Enclosure-A with the minimum qualification and experience requirements as given in Enclosure-B.

## 10. PERFORMANCE SECURITY

- 10.1 The successful consulting firm shall have to submit a Bank Guarantee (BG) for an amount of 10% of the Contract Value within 15 days of issue of LOA. The BG shall be valid for a period of 38 months i.e. upto 2 months beyond the expiry of the Contract of 36 months. The BG shall be in the format specified in Appendix I of draft contract form and furnished from a Nationalized Bank, IDBI or ICICI/ICICI Bank/Foreign Bank/EXIM Bank / Any Scheduled Commercial Bank approved by RBI having a networth of not less than 500 crore as per latest Annual Report of the Bank. In the case of a Foreign Bank (issued by a Branch in India) the networth in respect of Indian operations shall only be taken into account. In case of Foreign Bank, the BG issued by Foreign Bank should be counter guaranteed by any Nationalized Bank in India. In case of JV, the BG shall be furnished on behalf of the JV and not individually by the members.
- 10.2 Alternatively, a single Bank Guarantee to cover for the performance of all projects under NHAI may also be deposited as tabulated below, at the discretion of the consultant, instead of depositing separately again and again. The Consultant may initially provide the Performance Security for a period of two years provided that it shall procure the extension of the validity of the Performance Security at least one month prior to the date of expiry thereof. Once the appropriate single Bank Guarantee for Performance Security has been submitted by the Consultant, the existing BGs shall be returned. The Bank Guarantee be submitted in prescribed Performa.

Performance Security	
Remaining cumulative Value of Consultancy Fee as per Contracts under a Agency (NHAI) (Cr)	BG Value (in Rs. Crores.)
0-20	0.5
20-40	1
40-100	2.50
100-200	4.0
Beyond 200	5.0

## 11. AUTHORISED SIGNATORIES

The Authority shall require the Supervision Consultant to designate and notify to the Authority and the Contractor up to 2 (two) persons employed in its firm to sign for and on behalf of the Supervision Consultant, and any communication or document required to be signed by the Supervision Consultant shall be valid and effective only if signed by any of the designated persons; provided that the Supervision Consultant may, by notice in writing, substitute any of the designated persons by any of its employees.

**DATA SHEET****(As Mentioned in Letter of Invitation to Consultants)**

1. No Pre-Proposal Conference shall be held.
2. The proposal shall be valid for 120 days after the last date of submission.
3. Clarification may be requested 7 days prior to last date of submission of bids. The address for requesting clarification is:

General Manager (Tech) & Regional Officer,  
National Highways Authority of India  
Plot No. 3, Surya Towers,  
2<sup>nd</sup> Floor, 1<sup>st</sup> East Street,  
K.K Nagar,  
Madurai - 625 020.  
Tamil Nadu.  
Tel. No. 0452 2587750  
Fax No. 044 - 2587750  
E mail: [nhairomadurai@gmail.com](mailto:nhairomadurai@gmail.com)

The Language of documents and correspondence will be English

4. All the personnel shall have working knowledge of English and all the reports etc. shall be written in English.
5. NHAI shall reimburse only Goods and service tax. Consultant has to assess all other taxes and should inbuilt them in their financial proposal. These taxes (other than Goods and service tax) should not be provided separately. The Consultants to state cost in INR only.
6. The Consultants to ensure that their firms and key personnel should register their credentials / modules on [www.infracon.nic.in](http://www.infracon.nic.in) as stipulated in MoRT&H Circular No. RW-NH-35075/1/2010-S&R® dt. 28.10.2015.
7. The time and date of submission: 12.00 hrs. on.08.02.2018
8. The points assigned to Technical Evaluation criteria are:

S. No.	Description	Marks
1.	Relevant experience for the assignment	35
2.	Quality of approach and methodology	05
3.	Experience in use of technology for road inspection	20
4.	Qualifications and competence of the key staff for the assignment	40
	Total	100

**i. Sub criteria for Relevant Experience of the firm for the assignment**

Year of Establishment of the Firm (In case of JV year of establishment of LM shall be considered) (Min 5 Years)	2
Average Annual Turnover (last 5 years) from consultancy business (Min. 5 crore)	2
No. of key personnel with the firm	2
Experience in DPR/Feasibility cum PPR preparation for two projects of 4/6 laning of 30% of project length each or one project of 4/6 laning of 50% of project length in last 7 years	5
In hand DPRs for NHAI Projects ( presently under progress)	10
Experience as Independent Engineer/ Authority Engineer/ Supervision consultants for two construction projects of four/six laning of 30% of project length each or one projects of four/six laning of 50% of project length in last 7 years	6
Experience as Independent Engineer/ Supervision consultants one O&M project under DBFOT/OMT of four/six laning** of 50% of project length in last 7 years.	8

Employer's certificate should be submitted substantiating the experience claimed by the firm.

*\*\*Consultants should give details of the experience of the firm considering the completed and the on-going highway assignments, separately for PPP and non-PPP Projects along with experience certificates from clients. This list of the completed works should also include those assignments which are substantially (90% of Contract value) completed. No Qualification/Experience etc. shall be considered without proof of experience.*

Experience of Consultant for having offered consultancy services to a private organization shall also be considered as relevant experience for current assignment, provided the experience is duly endorsed by the respective Government Agency.

**ii. Sub criteria for Adequacy of the proposed work plan and methodology**

Site Appreciation	1
Quality of Approach and Methodology (approach and initial view on project plan including key challenges envisaged and potential solutions)	2
Internal Quality Audit Methodology to be adopted (Quality Assurance Plan)	2
<b>Total</b>	<b>5</b>

**iii. Sub criteria for Experience in use of technology for road inspection**

<b>S.No</b>	<b>Description</b>	<b>Maximum Points</b>	<b>Sub-Points</b>
<b>1</b>	<b>Experience in Network Survey Vehicle (NSV) or better technology for pavement inspection</b>	<b>6</b>	
1.1	Own an equipment/MOU with Associate		3
1.2	1-2 projects		4
1.3	3-5 projects		5
1.4	> 5 projects		6
<b>2</b>	<b>Experience in Falling Weight Deflectometer (FWD) or better technology for pavement strength measurement</b>	<b>3</b>	
2.1	Own an equipment/MOU with Associate		2
2.2	1-3 projects		2.5
2.3	> 3 projects		3
<b>3</b>	<b>Experience in Mobile Bridge Inspection Unit or better technology for bridge inspection</b>	<b>4</b>	
3.1	Own an equipment/MOU with Associate		2
3.2	1-3 projects		3
3.3	>3 projects		4
<b>4</b>	<b>Experience in Retro reflectometer technology</b>	<b>4</b>	
4.1	Own an equipment/MOU with Associate		2
4.2	1-3 projects		3
4.3	> 3 projects		4
<b>5</b>	<b>Experience in Automatic Traffic Counter cum Classifier (ATCC)</b>	<b>3</b>	
5.1	Own an equipment/MOU with Associate		1

S.No	Description	Maximum Points	Sub-Points
5.2	1-3 projects		2
5.3	> 3 projects		3
	<b>Total</b>	<b>20</b>	

**Note: A.** The consultants owning the equipments shall be required to submit proof of ownership.

**B.** The experience of the associate firms in use of technology shall also be counted in the evaluation. The experience of firm or associate firm in NSV, FWD, MBIU, Retro reflectometer, ATCC or equivalent technology shall be supported by experience certificate. The experience of a firm/associate firm for a private concessionaire/contractor shall be considered only if the experience certificate is authenticated by the concerned competent Government department/authority.

**iv. Qualification and competence of following professional/sub-professional staff** for the assignment shall be evaluated. The weightage for various key staff are as under:-

S.No	Staff Position	No. of Professional Staff	Marks per Staff	Total Marks
1	Team Leader cum Sr. Highway Engineer	1	19	19
2	Highway maintenance cum Resident Engineer	3	4	12
3	Bridge/Structural Engineer	1	4	4
4	Road Safety Expert	1	5	5
	<b>Total</b>			<b>40</b>

**Sub criteria for qualification of key Personnel (i.e. Professional staff)**

General qualifications	25
Adequacy for the project	70
Employment with firm	5
<b>Total</b>	<b>100</b>

**v.** The technical proposal should score at least 75 points to be considered responsive for financial evaluation.

- vi. Detailed evaluation criteria which is to be used for evaluation of technical bids is as indicated below as Appendix-EC.
- vii. The Consultant should carryout self-evaluation based on the evaluation criteria at Appendix-EC. While submitting the self-evaluation along with bid, Consultant shall make references to the documents which has been relied upon in his self-evaluation.
- viii. Result of technical evaluation shall be made available on the website giving opportunity to the bidders to respond within 7 days in case they have any objection.
- ix. The single currency for price conversion is INR. For evaluation of bid proposals, the foreign currency conversation rate of 1US Dollar = Rs. \*\*\*\*\* and 1 Euro = Rs.\*\*\*\*\* shall be used.
- x. The weightage given to technical proposal is  $T = 80\%$ . The weightage given to financial proposal is  $P = 20\%$ .
- xi. Commencement of Assignment: The firm shall begin carrying out the services within 15 days of signing of the Consultancy Agreement.

Remarks: Based on experience and the Consulting Industry's Capacity, Project specific requirement etc., NHAI may modify the above criteria for Selection of SC

### Section 3: FORMATS FOR SUBMISSION OF FIRMS CREDENTIALS

The proposal should contain the following information in enclosed format attached at Appendix A.

- Year of Establishment of Firm
- Average annual turnover (last five years)

Note: The Firm shall submit Certificate of Incorporation and audited balance sheet for the last five years ( FY 2012-2013, FY 2013-2014, 2014-15, 2015-16 & 2016-17)\*\*. For claiming experience of Highway projects, Completion Certificate from Employer should be enclosed. The proposal should also contain the details of the key personnel viz. their name, qualification, expertise area, experience and years of association with the firm.

#### Appendix A

The following information related to the firm should be provided in the proposal.

- i. Name of the package applied for:-
- ii. Year of establishment of firm \*

Consultant	Year of Establishment	Country	Type of Organization			
			Individual	Partnership	Corporation	Other
Individual / Lead Partner (of JV)						

*NOTE: - Year of Establishment of Lead Partner of JV shall be considered.*

*\*Copy of Certificate of incorporation shall be submitted.*

- iii. Office/Business Address/Telephone nos./Cable Address.
- iv. Narrative description of firm (Not more than 2 sheets)
- v. Name of two(2) principals who may be contacted with title and telephone number/fax number.
- vi. Financial Statement of the last five years. \*\*

S.No.	Particulars	2016-17	2015-16	2014-15	2013-14	2012-13
i.	Annual turnover from Consulting business					
ii.	Total Assets					
iii.	Current Assets					

- a. \*\*The amount shall be stated in INR. (Consider US\$1= \*\*\*\*\* INRs. and 1 Euro = \*\*\*\*\* INRs.)
- b. The currency conversion rate for the respective years shall be mentioned for other international currencies.
- c. Balance Sheet/ Auditor Certificate of last 5 years (2012-13 2013-14, 2014-15, 2015-16& 2016-17) shall be submitted as evidence of Annual Turnover”.
- d. Wherever details for Audited Balance Sheet, Financial Statement, Balance Sheet/Auditor Certificate of last 5 years are sought, the last 5 year shall be preceding the year in which Bid submission is to be made.

In case the annual accounts for the latest financial year are not audited and therefore the Applicant cannot make it available, the Applicant shall give an undertaking to this effect duly certified by statutory body like Chartered Accountant or Independent Auditor who are competent to do so as recognized by the state concerned. In such a case, the Applicant shall provide the Audited Annual Reports for 5 (five) years preceding the year for which the Audited Annual Report is not being provided.

- vii. Experience \*\*\* as Independent Engineer or Construction Supervision of Highway Projects, separately for PPP and non-PPP Projects during the last 7 years.

S. No	Projects Name/year	Type Services Rendered	Description of Highway Project/ Length (kms)	Client (with complete address, contact person, telephone Nos and Fax Nos)	Total Fee for the Consultancy Assignment (INR)	Fee Received by Applicant (in case of JV/ Association)	% Age of Total Fee Received by the Firm	Approx. Cost of Highway Project	Period
	Sole consultant Prime Consultant of JV/JV/or Sub Consultant								
1	2	3	4	5	6	7	8	9	10
		A. Completed/Substantially completed projects: 1. 2. 3. B. Projects in progress: 1. 2. 3.							

- viii. Experience \*\*\* in DPR/Feasibility Study of 4/6 laning Highway projects during the last 7 years.

S. No	Projects Name/year	Type Services Rendered	Length of Project (kms)	Client (with complete address, contact person, telephone Nos and Fax Nos)	Total Fee for the Consultancy Assignment (INR)	Fee in INR(Applicant's share in	% age of total fee received by the firm	Period
1	2	3	4	5	6	7	8	9

- ix. Experience \*\*\* in Project Supervision/IE for Operation and Maintenance of Highway Projects, separately for PPP and non-PPP Projects during the last 7 years.

S. No	Projects Name/ year	Type Services Rendered	Description of Highway Project/ Length (kms)	Client (with complete address, contact person, telephone Nos and Fax Nos)	Total Fee for the Consultancy Assignment (INR)	Fee Received by Applicant (in case of JV/ Association)	% Age of Total Fee Received by the Firm	Period
	Sole consultant Prime Consultant of JV/JV/or Sub Consultant							
1	2	3	4	5	6	7	8	9

- a. \*\*\*4/6 lane as applicable for the project for which RFP is invited. Experience of 4/6 lane shall be considered interchangeably for 4/6 laning projects.
- b. Only those projects, to be included in the table which are Highways Projects and for which clients certificates from the concerned Government agencies are enclosed with the proposal. The certificate should be issued by an Officer not below the rank of Executive Engineer.
- c. The weightage given for experience of a firm would depend on the role of the firm in the respective assignments. The firm's experience would get full credit if it was the sole firm in the respective assignment. Experience weightage for firms as Lead partner/JV partner/Associate shall be considered in the same proportion as payment has been received by the firm towards consultancy work in the project.

d. For weightage of experience in any past Consultancy assignment experience certificate from the client shall be accepted. In the absence of experience certificate from the client, proportion of payment received towards Consultancy work duly certified by statutory body like Chartered Accountant or Independent Auditors who are competent to do so as recognized by the State concerned shall be accepted. Annual turnover duly certified by Chartered Accountant shall be accepted. In case of non-availability of such documents no weightage of turnover/experience will be considered.

e. Assignments on hand including those for which the Letter of Acceptance from the clients received as on 7 days prior to due date for submission of proposals: The details shall be given in the following format.

S. No	Name of Assignment	Client	Role of the firm	Date of letter of Acceptance	Date of Agreement if signed	Present status of Assignment	Team Members provided by the firm		
			Sole, Lead/ Other in JV or sub-consultant				Name	DOB	Position
(1)	(2)	(3)	(4)	(5)	(6)	(7)	(8)	(9)	(10)

(f) Number of Key Personnel (as defined in RFP) employed with the firm in highway sector with more than one year from bid submission date:

Key Personnel	Number of key personnel employed		
	Sole Applicant (Lead Member in case of JV)	JV (1)	
Team Leader cum Senior Highway Engineer			
Resident cum Highway Engineer			
Bridge/Structural Engineer			
Road Safety Expert			

#### SECTION 4. FORMAT FOR SUBMISSION OF TECHNICAL PROPOSAL

<b>Appendix B-1</b>	Technical proposal submission form.
<b>Appendix B-2</b>	Site Appreciation
<b>Appendix B-3</b>	Approach paper on methodology for performing the assignment.
<b>Appendix B-4</b>	Facility for Field Investigations and Testing
<b>Appendix B-5</b>	Composition of the Team and Task(s) of each Team member
<b>Appendix B-6</b>	Curriculum vitae of proposed Professional staff.
<b>Appendix B-7</b>	Time schedule for deployment of Professional staff
<b>Appendix B-8</b>	Activity (works) schedule.
<b>Appendix B-9</b>	Affidavit for correctness of CVs of key personnel and experience claimed by the firm.
<b>Appendix B-10</b>	<i>Self-Evaluation by the Firm on the Annexure A, along with Annexure-A-1, Annexure A-2-1 to A-2-8 and Annexure A-3-1 to A-3-8</i>

**APPENDIX B-1**

**Technical Proposal Submission Form.**

From (Name of Firm)

To: (Name and Address of Client)

\_\_\_\_\_  
\_\_\_\_\_  
\_\_\_\_\_

\_\_\_\_\_  
\_\_\_\_\_  
\_\_\_\_\_

Ladies/Gentlemen:

Subject: Submission of Technical and Financial Proposal for engagement as SC for the Operation and Maintenance of

i.

We, the undersigned, offer to provide the consulting services for the above in accordance with your Request for Proposal dated \_\_, and our Proposal dated ..... while duly examining and understanding the contents of RFP. We are hereby submitting our Proposal, which includes this Technical Proposal and a Financial Proposal sealed under a separate envelope for the above mentioned work.

My/Our registration No. on Infracon is ..... and my/our Infracon Team ID is .....

We further certify that in the last 3 years, we or any member of our JV/Associates have neither failed to perform any contract/ assignment nor have been expelled from any contract/assignment nor had any contract/assignment terminated for our breach. our Proposal is binding upon us. We understand you are not bound to accept any Proposal you receive

We remain,

Yours sincerely,

Authorized Signatory  
Name and Address of Firm  
(Lead Member in case of JV)

**APPENDIX B-2 : : SITE APPRECIATION**

Shall give details of site as per actual site visit and data provided in RFP and collected from site supported by photographs to demonstrate that responsible personnel of the Consultant have actually visited the site and familiarized with the salient details/complexities and scope of services.

**APPENDIX B-3 : APPROACH PAPER ON METHODOLOGY FOR PERFORMING THE ASSIGNMENT**

The approach and methodology will be detailed precisely under the following topics.

1) Methodology or services, surveying, road condition data collection and analysis [not more than 2 pages]

2) Key challenges foreseen and proposed solutions in carrying out the assignment [not more than 1page]

3) Proposed Quality Audit Methodology and Quality Assurance Plan[not more than 6 pages]

**APPENDIX B-4 : FACILITY FOR FIELD INVESTIGATION AND TESTING**

1. State whether applicant has in-house (created in house at site)/ outsourced/ not available facility for
  - Surface defects detection and roughness measurement using Network Survey Vehicle
  - Pavement strength measurement using FWD
  - Bridge inspection using Mobile Bridge Inspection Unit
  - Road signs inspection using Retro Reflectometer
  - Traffic count using ATCC
2. In-case answer to 1 is available (created in house at site) a list of field investigation and testing equipment is to be attached
3. In case answer to 1 is outsourced/not available - arrangements made or proposed to be made for each of the above field investigations is to be attached
4. For experience in NSV, FWD, MBIU and reflectometer, references need to be provided in the following format:

**REFERENCES****Relevant Services Carried Which Best Illustrate Qualifications**

The following information should be provided in the form at below for each reference assignment for which your firm, either individually as a corporate entity or as one of the major companies within a consortium, was legally contracted by the client:

Assignment Name:		Country:
Location within Country:		Professional Staff Provided by your firm:
Name of Client :		No. of Staff :
Address :		No. of Staff Months :
Technology Used:		
Start Date (Month / Year)	Completion Date (Month / Year)	Approx. Value of Services :(in INR/current USD):
Name of JV/Association Firm(s)if any:		No. of Months of Professional Staff provided by Associated Firm(s)
Status of your Company in the Assignment i.e., Sole/Lead Member/Other Member/Associate		
Narrative Description of Project :		
Description of Actual Services Provided by your Company:		

**Signature of Authorised Representative**

**(Certificate from Employer regarding experience should be furnished)**

**APPENDIX B-5 : COMPOSITION OF THE TEAM PERSONNEL, AND TASK(S) OF EACH TEAM MEMBER**

## 1. Technical/Managerial Staff

Sl. No.	Name	Position	Task
1			
2			
3			
4			
...			
...			

## 2. Support Staff

Sl. No.	Name	Position	Task
1			
2			
3			
4			
...			
...			

## APPENDIX B-6 : FORMAT OF CURRICULUM VITAE (CV) FOR PROPOSED PROFESSIONAL STAFF

Proposed Position : .....

Name ..... of ..... Firm  
:.....

INFRACON ID (Firm) .....

Name ..... of ..... Staff  
:.....

INFRACON ID (Individual) .....

Profession :.....

Date of Birth :

Years with Firm/Entity :..... Nationality :  
..... Membership of Professional  
Societies:.....

Detailed Task Assigned :  
.....

Summary of Qualification & Experience vis-à-vis the requirements as per TOR

S. No	Name of Employer	Post Held	Project Name	Period		Assignment in the Project	Client of the Project	Remark
				From	To			

### Education:

[Summarise college/university and other specialised education of staff member, giving their names, dates attended, and degrees obtained. Use about one quarter of a page.]

### Key Qualifications:

[Give an outline of staff member's experience and training most pertinent to tasks on assignment. Describe degree of responsibility held by staff member on relevant previous assignments and give dates and locations. Use about half a page.]

### Employment Record:

[Starting with present position, list in reverse order every employment held. List all positions held by staff member since graduation, giving dates, name of employing organisations, titles

of positions held, and locations of assignments. For experience in last ten years, also give types of activities performed and client references, where appropriate. Use about three-quarters of a page.]

### Languages:

[For English language indicate proficiency: excellent, good, fair, or poor; in speaking, reading, and writing]

Summary of Qualification & Experience vis-à-vis the requirements as per TOR

Requirements as per TOR (Enclosure-B)	Possessed by the Staff Member	Break-up of experience	
		Brief Description of Project	Man-months provided

### Certification by the Candidate

I, the undersigned, (Name and Address) undertake that this CV correctly describes myself, my qualifications and my experience and NHAI would be at liberty to debar me if any information given in the CV, in particular the Summary of Qualification & Experience vis-à-vis the requirements as per TOR is found incorrect. I further undertake that I have neither been debarred by NHAI nor left any assignment with the consultants engaged by NHAI / contracting firm (firm to be supervised now) for any continuing work of NHAI without completing my assignment. I will be available for the entire duration of the current projects (named-----). If I leave this assignment in the middle of the work, NHAI would be at liberty to debar me from taking any assignment in any of the NHAI works for an appropriate period of time to be decided by NHAI. I have no objection if my services are extended by NHAI for this work in future.

I further undertake that if due to my inability to work on this project due to unavoidable circumstances, due to which consultant's firm is forced to seek replacement. In such unavoidable circumstances, I shall not undertake any employment in NHAI projects during the period of assignment of this project and NHAI shall consider my CV invalid till such time.

I undertake that I have no objection in uploading/hosting of my credentials by Employer in public domain.

For Key Personnel having intermittent inputs, add the following:

I further certify that I am associated with the following assignments as on date (as on 7 days prior to due date for submission of proposal) including those for which LOA has been received by the firm and the inputs in these assignments shall not effect the work of the current assignment.

Name of Assignment	Client	Date of LOA	Likely start (Month / Year)	Likely end (Month / Year)	Total input of the person (man-months)

.....  
(Signature of Key Personnel)

Date : .....  
(Day/Month/Year)

### Certification by the firm

The undersigned on behalf of ..... ( name of consulting firm) certify that the qualification and experience details of Shri ..... (name ..... of the proposed personnel and address) as described in the CV has been checked and found to be correct. It is also certified that Shri..... (name of proposed personnel) to the best of our knowledge has neither been debarred by NHAI nor left his assignment with any other consulting firm engaged by NHAI / Contracting firm (firm to be supervised now) for the ongoing projects. We understand that if the information about leaving the past assignment is known to NHAI, NHAI would be at liberty to remove the personnel from the present assignment and debar him for an appropriate period to be decided by NHAI.

.....  
[Signature of authorised representative of the Firm]

Date : .....  
(Day/Month/Year)

### Note:-

- Personnel is to affix his recent photograph on first page of CV.
- Complete address and phone number of the Personnel is to be provided.
- Document for proof of age is to be enclosed.
- Document for proof of qualification is to be enclosed.
- Age of the personnel shall not be more than as specified.
- Experience Certificates from Employers to be attached.

**APPENDIX B-7: TIME SCHEDULE FOR PROFESSIONAL PERSONNEL****A. Activity Schedule**

Sl.No	Name	Position	Monthwise Program (in form of Bar Chart) [1 <sup>st</sup> , 2 <sup>nd</sup> , etc. are months from the start of assignment]												Number of Months
			1 <sup>s</sup> t	2 <sup>n</sup> d	3 <sup>r</sup> d	4 <sup>t</sup> h	5 <sup>t</sup> h	6 <sup>t</sup> h	7 <sup>t</sup> h	8 <sup>t</sup> h	9 <sup>t</sup> h	10 <sup>t</sup> h	11 <sup>t</sup> h	12 <sup>th</sup> and subsequent years	
1															Subtotal (1)
2															Subtotal (2)
3															Subtotal (3)
4															Subtotal (4)
-															-
-															-

**APPENDIX B-8 : ACTIVITY (WORKS) SCHEDULE****A. Activity Schedule**

Sl. No.	Item of Activity (Works)	Monthwise Program (in form of Bar Chart) [1st, 2nd, etc. are months from the start of											
		1st	2nd	3rd	4th	5th	6th	7th	8th	9th	10th	11th	12th
1	..... .....												
2	..... .....												
3	..... .....												
4	..... .....												
-	..... .....												
-	..... .....												

**B. Completion and Submission of Reports**

Sl. No	Reports :	Programme : (Date)
1	Monthly reports(Design and Construction)	
2	Quarterly Reports	
3	Various others reports as provided in the Contract Agreement such as Completion Report	

**APPENDIX B-9: AFFIDAVIT FOR CORRECTNESS OF CV OF KEY PERSONNEL AND EXPERIENCE CLAIMED BY THE FIRMS**

(To be submitted on non-judicial Stamp Paper)

I, the undersigned, on behalf of \_\_ (name of the Consultant submitting the proposal), do hereby certify that the details furnished in this proposal including CV of key personnel and experience claimed by the firm/firms are true and correct to the best of my knowledge and belief.

Managing Director/Head of the  
Firm/Authorised Representative of the firm\*

Address

\*Lead Member in case of JV

**APPENDIX B-10: Self Evaluation by the Firm on the Annexure A, along with Annexure-A-1, Annexure A-2, Annexure A-3, Annexure A-4-1 to A-4-4 and Annexure A-5-1 to A-5-9.**

Name of the Firm:.....				
S. No.	Name of the Professional Staff	Marks of out of 100	Weightage Marks	Remark
Details			Marks	
1	Team Leader cum Sr. Highway Engineer (As per Annexure-A-4-1)		x/100*19	
2	Highway Maintenance cum Resident Engineer (As per Annexure- A-4-2)		x/100*12	
3	Road Safety Expert (As per Annexure-A-4-3)		x/100*4	
4	Bridge/Structural Engineer (As per Annexure- A-4-4)		x/100*5	
Maximum Marks 40		Total		0
Evaluation of the Firm (As per Annexure-A-1) Maximum 35			0	
Grand Total of Evaluation			0	
Managing Director/Head of the Firm/Authorized Representative of the firm				
Address:				
Lead Member in case of JV				

**APPENDIX B-11:****INTEGRITY PACT**

(To be executed on plain paper and submitted along with Technical Bid/Tender documents for tenders having a value between Rs.5 Cr and 100 Cr. To be signed by the bidder and same signatory competent/ authorized to sign the relevant contract on behalf of the NHAI)

Tender No. \_\_\_\_\_

This integrity Pact is made at \_\_\_\_\_ on this \_\_\_\_\_ day of \_\_\_\_\_ 2016.

Between

National Highways Authority of India (NHAI), a statutory body constituted under the National Highways Authority of India Act, 1988, which has been entrusted with the responsibility of development, maintenance and management of National Highways, having its office at Plot No. 3, Surya Towers, 1<sup>st</sup> East Street, K.K Nagar, Madurai – 625 020, hereinafter referred to as “**The Principal**”, which expression shall unless repugnant to the meaning or contract thereof include its successors and permitted assigns.

and

\_\_\_\_\_ hereinafter referred to as “**The Bidder/Contractor /Concessionaire/Consultant**” and which expression shall unless repugnant to be meaning or context thereof include its successors and permitted assigns.

**Preamble**

Whereas, the Principal intends to award, under laid down organizational procedures, contract/s for “Supervision Consultant services for the project of Operation & Maintenance of 4 laning of Madurai – Tirunelveli – Panagudi – Kanniyakumari Section from Km 0/000 to Km 243/170 of NH-7 (New NH.44) including construction of Bridge at Narikulam Tank Portion at km 230/700 to Km 231/250 and Improvement of Approach Road to ROB at Km 0/600 at Samayanallur of NH-7(New NH.44) and Operation & Maintenance of Tuticorin – Tirunelveli Section from Km 0/000 to km 47/250 of NH-7A (New NH.138) in the State of Tamil Nadu”. The Principal values full compliance with all relevant laws of the land, rules of land, regulations, economic use of resources and of fairness/ transparency in its relations with its Bidder(s) and/ or Contractor(s)/Concessionaire(s)/ Consultant(s).

And whereas to meet the purpose aforesaid, both the parties have agreed to enter into this Integrity Pact (hereafter referred to as Integrity Pact) the terms and conditions of which shall also be read as integral part and parcel of the Tender documents and contract between the parties. Now, therefore, in consideration of mutual covenants stipulated in this pact, the parties hereby agree as follows and this pact witnesses as under:-

**Article-1 Commitments of the Principal**

- 1) The Principal commits itself to take all measures necessary to prevent corruption and to observe the following principles:-

- a. No employee of the Principal, personally or through family members, will in connection with the tender for, or the execution of a contract, demand, take a promise for or accept, for self, or third person, any material or immaterial benefit which the person is not legally entitled to.
  - b. The Principal will, during the tender process treat all Bidder(s) with equity and reason. The Principal will in particular, before and during the tender process, provide to all Bidder(s) the same information and will not provide to any Bidder(s) confidential/ additional information through which the Bidder(s) could obtain an advantage in relation to the tender process or the contract execution.
  - c. The Principal will exclude all known prejudiced persons from the process, whose conduct in the past has been of biased nature.
- 2) If the Principal obtains information on the conduct of any of its employees which is a criminal offence under the IPC/PC Act or any other Statutory Acts or if there be a substantive suspicion in this regard, the Principal will inform the Chief Vigilance Officer and in addition can initiate disciplinary actions as per its internal laid down Rules/Regulations.

#### **Article – 2 Commitments of the Bidder(s)/ Contractor(s)/ Concessionaire(s)/ Consultant(s).**

The Bidder(s)/ Contractor(s)/ Concessionaire(s)/ Consultant(s) commit himself to take all measures necessary to prevent corruption. He commits himself to observe the following principles during his participation in the tender process and during the contract execution.

- a. The Bidder(s)/ Contractor(s)/ Concessionaire(s)/ Consultant(s) will not, directly or through any other person or firm, offer, promise or give to any of the Principal's employees involved in the tender process or the execution of the contract or to any third person any material or other benefit which he/she is not legally entitled to, in order to obtain in exchange any advantage of any kind whatsoever during the tender process or during the execution of the contract.
- b. The Bidder(s)/ Contractor(s)/ Concessionaire(s)/ Consultant(s) will not enter with other Bidders into any undisclosed agreement or understanding, whether formal or informal. This applies in particular to prices, specifications, certifications, subsidiary contracts, submission or non-submission or bids or any other actions to restrict competitiveness or to introduce cartelization in the bidding process.
- c. The Bidder(s)/ Contractor(s)/ Concessionaire(s)/ Consultant(s) will not commit any offence under the relevant IPC/PC Act and other Statutory Acts; further the Bidder(s)/ Contractor(s)/ Concessionaire(s)/ Consultant(s) will not use improperly, for purposes of completion or personal gain, or pass on to others, any information or document provided by the Principal as part of the business relationship, regarding plans, technical proposals and business details, including information contained or transmitted electronically.
- d. The Bidder(s)/ Contractor(s)/ Concessionaire(s)/ Consultant(s) of foreign-origin shall disclose the name and address of the Agents/ Representatives in India, if any. Similarly the Bidder(s)/ Contractor(s)/ Concessionaire(s)/ Consultant(s) of Indian Nationality shall furnish the name and address of the foreign principle, if any.
- e. The Bidder(s)/ Contractor(s)/ Concessionaire(s)/ Consultant(s) will, when presenting his bid, disclose any and all payments he has made, is committed to or intends to make to agents,

- brokers or any other intermediaries in connection with the award of the contract. He shall also disclose the details of services agreed upon for such payments.
- f. The Bidder(s)/ Contractor(s)/ Concessionaire(s)/ Consultant(s) will not instigate third persons to commit offences outlined above or be an accessory to such offences.
  - g. The Bidder(s)/ Contractor(s)/ Concessionaire(s)/ Consultant(s) will not bring any outside influence through any Govt. bodies/quarters directly or indirectly on the bidding process in furtherance of his bid.

### **Article – 3 Disqualification from tender process and exclusion from future contracts.**

1. If the Bidder(s)/ Contractor(s)/ Concessionaire(s)/ Consultant(s), before award or during execution has committed a transgression through a violation of any provision of Article-2, above or in any other form such as to put his reliability or credibility in question, the Principal is entitled to disqualify the Bidder(s)/ Contractor(s)/ Concessionaire(s)/ Consultant(s) from the tender process.
2. If the Bidder/ Contractor/ Concessionaire/ Consultant has committed a transgression through a violation of Article-2 such as to put his reliability or credibility into question, the Principal shall be entitled to exclude including blacklist and put on holiday the Bidder/ Contractor/ Concessionaire/ Consultant for any future tenders/ contract award process. The imposition and duration of the exclusion will be determined by the severity of the transgression. The severity will be determined by the Principal taking into consideration the full facts and circumstances of each case particularly taking into account the number of transgressions, the position of the transgressors within the company hierarchy of the Bidder/ Contractor/ Concessionaire/ Consultant and the amount of the damage. The exclusion will be imposed for a minimum of 1 year.
3. A transgression is considered to have occurred if the Principal after due consideration of the available evidence concludes that “On the basis of facts available there are no material doubts”.
4. The Bidder/ Contractor/ Concessionaire/ Consultant with its free consent and without any influence agrees and undertakes to respect and uphold the Principal’s absolute rights to resort to and impose such exclusion and further accepts and undertakes not to challenge or question such exclusion on any ground, including the lack of any hearing before the decision to resort to such exclusion is taken. This undertaking is given freely and after obtaining independent legal advice.
5. The decision of the Principal to the effect that a breach of the provisions of this Integrity Pact has been committed by the Bidder/ Contractor/ Concessionaire/ Consultant shall be final and binding on the Bidder/ Contractor/ Concessionaire/ Consultant.
6. On occurrence of any sanctions/ disqualification etc arising out from violation of integrity pact, the Bidder/ Contractor/ Concessionaire/ Consultant shall not be entitled for any compensation on this account.
7. Subject to full satisfaction of the Principal, the exclusion of the Bidder/ Contractor/ Concessionaire/ Consultant could be revoked by the Principal if the Bidder/ Contractor/ Concessionaire/ Consultant can prove that he has restored/ recouped the damage caused by him and has installed a suitable corruption prevention system in his organization.

### **Article – 4 Compensation for Damages.**

1. If the Principal has disqualified the Bidder(s) from the tender process prior to the award according to Article-3, the Principal shall be entitled to forfeit the Earnest Money Deposit/ Bid Security or demand and recover the damages equivalent to Earnest Money Deposit/ Bid Security apart from any other legal right that may have accrued to the Principal.
2. In addition to 1 above, the Principal shall be entitled to take recourse to the relevant provisions of the contract related to Termination of Contract due to Contractor/ Concessionaire/Consultant's Default. In such case, the Principal shall be entitled to forfeit the Performance Bank Guarantee of the Contractor/ Concessionaire/ Consultant and/ or demand and recover liquidated and all damages as per the provisions of the contract/concession agreement against Termination.

#### **Article – 5 Previous Transgression**

1. The Bidder declares that no previous transgressions occurred in the last 3 years immediately before signing of this Integrity Pact with any other Company in any country conforming to the anti corruption/ Transparency International (TI) approach or with any other Public Sector Enterprise/ Undertaking in India or any Government Department in India that could justify his exclusion from the tender process.
2. If the Bidder makes incorrect statement on this subject, he can be disqualified from the tender process or action for his exclusion can be taken as mentioned under Article-3 above for transgressions of Article-2 and shall be liable for compensation for damages as per Article-4 above.

#### **Article-6 Equal treatments of all Bidders/ Contractors/ Concessionaires/ Consultants/ Subcontractors.**

1. The Bidder(s)/ Contractor(s)/ Concessionaire(s)/ Consultant(s) undertake(s) to demand from all sub-contractors a commitment in conformity with this Integrity Pact, and to submit it to the Principal before contract signing.
2. The Principal will enter into agreements with identical conditions as this one with all Bidders/ Contractors/ Concessionaires/ Consultants and Subcontractors.
3. The Principal will disqualify from the tender process all Bidders who do not sign this Pact or violate its provisions.

#### **Article – 7 Criminal charges against violating Bidder(s)/ Contractor(s)/ Concessionaire(s)/ Consultant(s)/ Sub-contractor(s).**

If the Principal obtains knowledge of conduct of a Bidder/ Contractor/ Concessionaire/ Consultant or Subcontractor, or of an employee or a representative or an associate of a Bidder/ Contractor/ Concessionaire/ Consultant or Subcontractor, which constitutes corruption, or if the Principal has substantive suspicion in this regard, the Principal will inform the same to the Chief Vigilance Officer.

#### **Article – 8 Pact Duration**

This Pact begins when both parties have legally signed it. (In case of EPC i.e. for projects funded by Principal and consultancy services). It expires for the Contractor/ Consultant 12 months after his Defect Liability period is over or 12 months after his last payment under the contract whichever is later and for

all other unsuccessful Bidders 6 months after this Contract has been awarded. (In case of BOT/OMT Projects) It expires for the Contractor 24 months after his Contract period is over and for all other unsuccessful Bidders 6 months after this Contract has been awarded.

If any claim is made/ lodged during this time, the same shall be binding and continue to be valid despite the lapse of this pact as specified above, unless it is discharged/ determined by Chairman of NHAI.

**Article - 10 Other Provisions.**

1. This pact is subject to Indian Law. Place of performance and jurisdiction is the Registered Office of the Principal, i.e. Madurai.
2. Changes and supplements as well as termination notices need to be made in writing.
3. If the Bidder/Contractor/Concessionaire/Consultant is a partnership or a consortium, this pact must be signed by all partners or consortium members.
4. Should one or several provisions of this agreement turn out to be invalid, the remainder of this agreement remains valid. In this case, the parties will strive to come to an agreement to their original intentions.
5. Any disputes/ differences arising between the parties with regard to term of this pact, any action taken by the Principal in accordance with this Pact or interpretation thereof shall not be subject to any Arbitration.
6. The actions stipulated in this Integrity Pact are without prejudice to any other legal action that may follow in accordance with the provisions of the extant law in force relating to any civil or criminal proceedings.

In witness whereof the parties have signed and executed this Pact at the place and date first done mentioned in the presence of following witness:-

\_\_\_\_\_  
(For & On behalf of the Principal)

\_\_\_\_\_  
(For & On behalf of the Bidder/  
Contractor/ Concessionaire/ Consultant )

(Office Seal )

Place\_\_\_\_\_

Date\_\_\_\_\_

**Witness 1 :**

(Name & Address):\_\_\_\_\_

**Witness 2 :**

(Name & Address): \_\_\_\_\_

## Annexure-A-1

Evaluation Sheet (Relevant Experience of Firm for the Assignment Total Marks = 35)				
S. No.	Description	Marks	Name of Firm:-	Certificate attached (Page No.)/Remark
1	Year of Establishment of the Firm (In case of JV year of establishment of Lead Member shall be considered) (Min 5 years) For 5 years - 1.5 marks More than 5 years - 2 marks	2		
2	Average Annual Turnover (last 5 years or in each of the preceding two years) from consultancy business (Min 5 Crore) For >50 Crores - 2 marks For 20-50 Crores- 1.5 marks For 10-20 Crores- 1 mark For 5-10 Crores- 0.5 mark	2		
3	Numbers of key personnel with the firm more than one year with the firm. <4 personnel - 0 marks 4 to 12 - Linearly varying from 0.25 to 2 > 12 personnel - 2 marks	2		
4	Experience in DPR/Feasibility cum PPR preparation for two projects of 4/6 laning of 30% of project length each or one project of 4/6 laning of 50% of project length in last 7 years 2 project 4/6 laning of 30% of project length each - 4 marks Or 1 project of 4/6 laning of 50% of project length - 4 marks Add 0.25 (Zero point two five) marks extra for each additional project subject to maximum 1 marks.	5		
5	In hand DPRs for NHAI Projects For DPR project length > the length of project for which RFP invited -5 Marks For DPR project length > two times the length of project for which RFP invited -7.5	10		

<b>Evaluation Sheet (Relevant Experience of Firm for the Assignment Total Marks = 35)</b>				
<b>S. No.</b>	<b>Description</b>	<b>Marks</b>	<b>Name of Firm:-</b>	<b>Certificate attached (Page No.)/Remark</b>
	Marks For project length > three times the length of project for which RFP invited - 10 Marks			
6	Experience as Independent Engineer/Authority Engineer/Supervision Consultant two construction projects of four/six laning ** of 30% of project length each or one projects of four/six laning ** of 50% project length in last 7 years. 2 construction projects 4/6 laning of 30% of project length each - 4marks Or 1 construction project of 4/6 laning of 50% of project length - 4 marks Add 1(one) mark extra for completed assignment of Independent Engineer/ supervision consultancy subject to maximum 2 (two) mark.	6		
7	Experience as Independent Engineer/Supervision Consultants one O&M project under DBFOT/OMT/O&M of four/six laning** of 50% of project length in last 7 years 1 project - 6 marks Add 0.5 (Zero point five) marks extra for each additional project subject to maximum 2 marks.	8		
	<b>Total</b>	<b>35</b>		

**Anneuxre-A-2**

<b>Evaluation Sheet (Adequacy of the Proposed Approach and Methodology)</b>			
<b>Description</b>	<b>Maximum Marks</b>	<b>Reference/Details of projects Claimed for self assessment</b>	<b>Marks self assessed by the bidder</b>
Site Appreciation (i) Average 0.50 (ii) Good 0.75 (iii) Very Good 1.00	<b>1</b>		
Quality of Approach and Methodology (Review of scope of work and design review, construction supervision methodology, contract management approach, safety review/audit and O&M stage, initial view on project plan including key challenges envisaged and potential solutions to be judged).€ (i) Average 0.75 (ii) Good 1.50 (iii) Very Good 2.00	<b>2</b>		
Quality Audit Methodology and Quality Assurance Plan (i) Average 0.75 (ii) Good 1.50 (iii) Very Good 2.00	<b>2</b>		
<b>Total Marks</b>	<b>5</b>		

**Anneuxre-A-3**

<b>Evaluation sheet for assessment of experience in use of technology for road inspection</b>				
<b>S.No</b>	<b>Description</b>	<b>Maximum Points</b>	<b>Reference/Details of projects Claimed for self assessment</b>	<b>Marks self assessed by the bidder</b>
<b>1</b>	<p>Experience in Network Survey Vehicle (NSV) or better technology for pavement inspection</p> <ul style="list-style-type: none"> <li>• Own an equipment/MOU with Associate - 3</li> <li>• 1-2 projects- 4</li> <li>• 3-5 projects- 5</li> <li>• &gt;5 projects- 6</li> </ul>	<b>6</b>		
<b>2</b>	<p>Experience in Falling Weight Deflectometer (FWD) or better technology for pavement strength measurement</p> <ul style="list-style-type: none"> <li>• Own an equipment/MOU with Associate - 2</li> <li>• 1-3 projects- 2.5</li> <li>• &gt;3 projects- 3</li> </ul>	<b>3</b>		
<b>3</b>	<p>Experience in Mobile Bridge Inspection Unit (MBIU) or better technology for bridges inspection</p> <ul style="list-style-type: none"> <li>• Own an equipment/MOU with Associate - 2</li> <li>• 1-3 projects -3</li> <li>• &gt;3 projects -4</li> </ul>	<b>4</b>		
<b>4</b>	<p>Experience in Retro reflectometer technology</p> <ul style="list-style-type: none"> <li>• Own an equipment/MOU with Associate - 2</li> </ul>	<b>4</b>		

<b>Evaluation sheet for assessment of experience in use of technology for road inspection</b>				
<b>S.No</b>	<b>Description</b>	<b>Maximum Points</b>	<b>Reference/Details of projects Claimed for self assessment</b>	<b>Marks self assessed by the bidder</b>
	<ul style="list-style-type: none"> <li>• 1-3 projects- 3</li> <li>• &gt;3 projects- 4</li> </ul>			
<b>5</b>	Experience in ATCC <ul style="list-style-type: none"> <li>• Own an equipment/MOU with Associate - 1</li> <li>• 1-3 projects- 2</li> <li>• &gt;3 projects- 3</li> </ul>	<b>3</b>		
	<b>Total</b>	<b>20</b>		

**Anneuxre-A-4-1**

<b>Evaluation Sheet -Team Leader cum Sr. Highway Engineer</b>				
<b>S. N.</b>	<b>Description</b>	<b>Max. Marks</b>	<b>Name of Firm:.....</b>	<b>Remarks</b>
<b>1</b>	<b>General Qualification/Name/DOB</b>	<b>25</b>	<b>Name of Team Leader:.....</b>	
	i. Graduate in Civil Engineering -21 marks ii. Post Graduation in Management/ Construction/ Transportation/ Highway Engineering/ Structural Engineering/ any other specialized stream of civil engineering. - 04 marks.	25		
<b>2</b>	<b>Adequacy for the project</b>	<b>70</b>		
<b>Professional Experience in Highway Projects:</b>				
i)	Total Highway Professional Experience < 10 years -0 10 years -22 Add two marks extra for each additional completed year of experience subject to maximum 8 (eight) marks.	30		
ii)	Experience as Team leader/Project Manager or in Similar Capacity* in O&M of completed 4/6 lane highway sections < 3 years -0 3 years -30 Add 2.5 marks extra for each additional year of experience subject to maximum 5 (five) marks.	35		
iii)	Experience in similar capacity* in Highway Development Projects taken up under EPC 1 projects - 4 marks add 1 mark extra for additional projects subject to maximum 1 (one) marks	5		
<b>3</b>	<b>Employment with the Firm</b> < 1 year -0 1 year -3 Add 0.5 marks for each subsequent year subject to maximum 2 marks	<b>5</b>		
	<b>Total</b>	<b>100</b>		

\*Similar Capacity includes the following positions

- i. On behalf of Consultant: Team Leader/Resident Engineer (Construction Supervision/IE)
- ii. On behalf of Contractor: Project Manager (Construction/Construction Supervision)
- iii. In Government Organizations: Superintending Engineer (or equivalent) and above

In case of experience on behalf of Consultant or Contractor, the experience shall be duly endorsed by the respective Government agency. In case of non-availability of endorsement from Govt. Agency, the experience uploaded on Infracon Portal will be taken into consideration. However, the key personnel/ bidder will be solely responsible for any fake information/ CV, which may result in debarment.

**Annexure-A-4-2**

<b>Evaluation Sheet - Highway Maintenance cum Resident Engineer</b>				
<b>S. No.</b>	<b>Description</b>	<b>Max. Marks</b>	<b>Name of Firm:.....</b>	<b>Remark</b>
	<b>General Qualification/Name/DOB</b>	<b>25</b>	<b>Name of Highway Maintenance Engineer:.....</b>	
	i. Graduate in Civil Engineering- 21 marks ii. Post Graduation in Highway Engg.- 04 marks	25		
<b>2</b>	<b>Adequacy for the project</b>	<b>70</b>		
<b>Professional Experience</b>				
i)	Experience in Highway works (inspection/design/construction/maintenance) <7 years -0 7years -22 Add two marks extra for each additional completed year of experiences subject to maximum 8 (eight) marks.	30		
ii)	Experience in similar capacity* in highway Construction / Maintenance works of similar nature < 3 years -0 3 years -12 Add one marks extra for each additional completed year of experiences subject to maximum 3 (three) marks.	15		
iii)	Experience in similar capacity* in project involving Construction/Maintenance works of 4/6 laning/Expressways 1 project -20 Add 2.5 marks extra for each project to maximum 5 (five) marks.	25		
<b>3</b>	<b>Employment with the Firm</b> < 1 year -0 1 year -3 Add 0.5 marks for each subsequent year subject to maximum 2 marks	<b>5</b>		
	<b>Total</b>	<b>100</b>		

\*Similar Capacity includes the following positions

- i. On behalf of Consultant: Highway Engineer/ Highway Maintenance Engineer/ Resident Engineer (Construction Supervision/IE)
- ii. On behalf of Contractor: Highway Engineer / Project Manager (Construction/Construction Supervision)
- iii. In Government Organizations: Executive Engineer (or equivalent) and above

In case of experience on behalf of Consultant or Contractor, the experience shall be duly endorsed by the respective Government agency. In case of non-availability of endorsement from Govt. Agency, the experience uploaded on Infracon Portal will be taken into consideration. However, the key personnel/ bidder will be solely responsible for any fake information/ CV, which may result in debarment.

**Annexure-A-4-3**

<b>Evaluation Sheet - Road Safety Expert</b>				
<b>S. No.</b>	<b>Description</b>	<b>Max. Marks</b>	<b>Name of Firm:.....</b>	<b>Remark</b>
<b>1</b>	<b>General Qualification/Name/DOB</b>	<b>25</b>	<b>Name of Road Safety Expert:.....</b>	
	Graduate in Civil Engineering - 21 marks Post-Graduation in Traffic/Transportation/Safety Engineering- 04 marks	25		
<b>2</b>	<b>Adequacy for the project</b>	<b>70</b>		
<b>Professional Experience</b>				
i)	Total Professional Experience <7years -0 7years -22 Add two mark extra for each additional year of experience subject to maximum 8 (eight) marks.	30		
ii)	Experience in similar capacity in Road Safety Works of Major Highway Projects (4/6 laning Projects) < 3years -0 3years -17 Add one mark extra for each additional year of experience subject to maximum 3(three) marks.	20		
iii)	Experience in similar capacity in Road Safety Audit of 4/6 lane highway/Expressway projects. 1 nos. -12 Add 1 (one) mark extra for each additional project subject to maximum 3(three) marks.	15		
iv)	Experience in similar capacity in preparation of Road Safety Management Plan for Inter Urban Highways 1project -3marks More than one project - 5 marks	5		
<b>3</b>	<b>Employment with the Firm</b> < 1 year - 0 1 year - 3 Add 0.5 marks for each subsequent year subject to maximum 2 marks	<b>5</b>		
	<b>Total</b>	<b>100</b>		

\*Similar Capacity includes the following positions

- i. On behalf of Consultant: Road Safety Expert (Construction Supervision/IE)
- ii. On behalf of Contractor: Road safety Expert (Construction/Construction Supervision)
- iii. In Government Organizations: Executive Engineer (or equivalent) and above

In case of experience on behalf of Consultant or Contractor, the experience shall be duly endorsed by the respective Government agency. In case of non-availability of endorsement from Govt. Agency, the experience uploaded on Infracon Portal will be taken into consideration. However, the key personnel/ bidder will be solely responsible for any fake information/ CV, which may result in debarment.

**Annexure-A-4-4**

<b>Evaluation Sheet - Bridge/Structural Engineer</b>				
<b>S. No.</b>	<b>Description</b>	<b>Max. Marks</b>	<b>Name of Firm:.....</b>	<b>Remark</b>
<b>1</b>	<b>General Qualification/Name/DOB</b>	<b>25</b>	<b>Name of Bridge/Structural Engineer:.....</b>	
	Graduate in Civil Engineering - 21 marks Post Graduation in Structural Engineering - 04 marks.	25		
<b>2</b>	<b>Adequacy for the project</b>	<b>70</b>		
<b>Professional Experience</b>				
i)	Total Professional Experience <7 years -0 7years -22 Add two mark extra for each additional completed year subject to maximum 8(eight) marks.	30		
ii)	Experience in similar capacity in Construction/Construction Supervision of Bridge/Interchange/any other structures including rehabilitation < 3 years -0 3 years -16 Add one marks extra for each additional completed year of experience subject to maximum 4 (four) marks.	20		
iii)	Experience in similar capacity in Construction/Construction Supervision of Bridge/Interchange/any other structures including rehabilitation of 4/6 lane highway/expressway or similar project. 1 Project -16 Add1 (one) mark extra for each additional project subject to maximum 4 (four) mark	20		
<b>3</b>	<b>Employment with the Firm</b> < 1 year -0 1 year -3 Add 0.5 marks for each subsequent year subject to maximum 2 marks	<b>5</b>		
	<b>Total</b>	<b>100</b>		

\*Similar Capacity includes the following positions

- i. On behalf of Consultant: Bridge Engineer/ Bridge Design Engineer/ Structural Engineer
- ii. On behalf of Contractor: Bridge Engineer/ Bridge Design Engineer/ Structural Engineer
- iii. In Government Organizations: Executive Engineer (or equivalent) and above

In case of experience on behalf of Consultant or Contractor, the experience shall be duly endorsed by the respective Government agency. In case of non-availability of endorsement from Govt. Agency, the experience uploaded on Infracon Portal will be taken into consideration. However, the key personnel/ bidder will be solely responsible for any fake information/ CV, which may result in debarment.

**Note applicable to all key personnel:**

1.If a key personnel has worked in next lower category to the similar capacity, the marks allotted to key personnel in the category 'experience in similar capacity' shall be reduced to two thirds of marks in this category. This shall be applicable for evaluation of all key personnel.

2. Similar projects means 2/4/6 lane as applicable for the project for which RFP is invited. For 2-lane projects experience of 4/6 lane also to be considered with a multiplication factor of 1.5. Experience of 4/6 lane shall be considered interchangeably for 4/6 laning projects. For 4/6 laning projects, experience of 2 lane will be considered with a multiplication factor of 0.4.

**Annexure-A-5-1 Evaluation Sheet Details -Team Leader-**

S. No.	Name of Employee	Post Held	Nature of work	Name of Employer	Client	Total Period	Period		Experience certificate Page No.
							From	To	

**Annexure-A-5-2 Evaluation Sheet Details -Highway Maintenance Engineer-**

S. No.	Name of Employee	Post Held	Nature of work	Name of Employer	Client	Total Period	Period		Experience certificate Page No.
							From	To	

**Annexure-A-5-3 Evaluation Sheet Details -Road Safety Expert**

S. No.	Name of Employee	Post Held	Nature of work	Name of Employer	Client	Total Period	Period		Experience certificate Page No.
							From	To	

**Annexure-A-5-4 Evaluation Sheet Details -Bridge/Structural Engineer**

S. No.	Name of Employee	Post Held	Nature of work	Name of Employer	Client	Total Period	Period		Experience certificate Page No.
							From	To	

**SECTION 5 FORMAT FOR SUBMISSION OF FINANCIAL PROPOSAL.**

**Appendix C-1:**Financial proposal submission form

**Appendix C-2:**Summary of costs

**Appendix C-3:**Breakdown of local currency costs

**APPENDIX C-1 : FINANCIAL PROPOSAL SUBMISSION FORM****FROM : (Name of Firm)****TO :**

General Manager (Tech) & Regional  
Officer,  
National Highways Authority of India  
Plot No. 3, Surya Towers,  
2<sup>nd</sup> Floor, 1<sup>st</sup> East Street,  
K.K Nagar,  
Madurai - 625 020.  
Tamil Nadu.  
Tel. No. 0452 2587750  
Fax No. 044 - 2587750  
E mail: [nhairomadurai@gmail.com](mailto:nhairomadurai@gmail.com)

**Subject :**

We, the undersigned, offer to provide the consulting services for the above in accordance with your Request for Proposal dated [Date], and our proposal. Our attached financial proposal is for the sum of [Amount in words and figures]. This amount is exclusive of the local taxes which we have estimated at (Amount in Words and Figures).

Our financial proposal shall be binding upon us up to the expiration of the validity period of the proposal, i.e., [Date].

We undertake that, in competing for (and, if the award is made to us, in executing) the above contract, we will strictly observe the laws against fraud and corruption in force in India namely "Prevention of Corruption Act 1988".

Commission and gratuities, if any, paid or to be paid by us to agents relating to this proposal and contract execution, if we are awarded the contract, are listed below:

Name and Address of Agents	Amount and Currency	Purpose of Commission or Gratuity
.....	.....	.....
.....	.....	.....

We understand you are not bound to accept any proposal you receive.

We remain, Yours sincerely,

**Managing Director/Head of the firm/  
Authorised Representative of the firm\***

Name of the firm

Address

\*Lead Member in case of JV

**APPENDIX C-2 :SUMMARY OF COSTS**

No.	Description	Amount (:LC)*
	<b>Local Consultants</b>	
I	Remuneration for Local Professional Staff	
II	Supporting Staff	
III	Transportation	
IV	Duty Travel to Site	
V	Office Rent	
VI	Office Supplies, Utilities and Communication	
VII	Office Furniture and Equipment	
VIII	Reports and Document Printing	
IX	Road Survey Equipment	
	<b>Sub total Local Consultant</b>	
	<b>Foreign Consultants</b>	
F-1	Remuneration for Expatriate Staff	
F-II	Mobilization and Demobilisation	
F-IV	Other Costs	
	<b>Subtotal Foreign Consultants</b>	
	Goods and Services Tax Payable in India	
	<b>Total Costs (Including Tax)</b>	

LC\* Local Currency

Note:

- i. The remuneration shall include the cost of accommodation and all other miscellaneous personal expenses as required for carrying out the assignment.
- ii. Any travel related expenditure incurred by the Team Leader on account of his/her involvement in multiple projects shall be deemed to be included in the cost quoted for the project and shall not be payable separately.
- iii. Payments will be made as per stipulations of the Conditions of Contract.



**APPENDIX C-3 : BREAKDOWN OF LOCAL CURRENCY COSTS****I. REMUNERATION FOR LOCAL PROFESSIONAL STAFF**

No.	Position	Name	3 Years		
			No. of man-months*	Rate	Amount
	<b>Key Personnel (Professional Staff)</b>				
1.	Team Leader cum Sr. Highway Engineer		1 x 36		
2	Highway Maintenance Cum Resident Engineer		3 x 36		
3	Road Safety Expert		1 x 9		
4	Bridge/Structural Engineer		1 x 14		
	<b>Sub - Total</b>		<b>167</b>		
	<b>Sub-professional</b>				
1	Assistant Highway Maintenance Engineer	TBN	5 x 36		
2	Assistant Quality cum Material Engineer	TBN	2 X 36		
3	Assistant Bridge Engineer	TBN	2 X 24		
4	CAD Expert	TBN	1 x 10		
5	Electrical Engineer	TBN	1 x 7		
6	Horticulture Expert	TBN	1 x 36		
7	Quantity Surveyor	TBN	2 X 36		
8	IT Expert	TBN	5 X 36		
	<b>Total</b>		<b>605</b>		

Note: The S. No. 2,3,7,8,of sub professional staff will be mobilized as per requirement of PIU, Madurai

TBN = To Be Named

\*The man-month against each key personnel/sub - professional shall be same as specified in Enclosure A.

**II. Support Staff**

S.No.	Position	Name	Staff Months	Billing Rate ( )	Amount ( )
1	Technical Supervisor	TBN	5 x 36		
2	Office Manager	TBN	1 x 36		
3	Accountant-cum-Cashier	TBN	1 x 36		
4	Steno-Cum- Computer Operator	TBN	2 x 36		
5	Office Boy	TBN	2 x 36		
		<b>Total</b> :	<b>396</b>		

**Note :** Billing rates as indicated above shall be increased in accordance with clause 6.2(a) Special Conditions of Contract for the personnel of all categories namely (i) key Personnel; (ii) sub- Professional personnel and (iii) Support staff. The increase as above shall be payable only on the remuneration part of Key Personnel, Sub-Professional Personnel and support staff. However, for evaluation of Bid proposals, the quoted initial rate shall be multiplied by the total time input for each position on this contract, i.e. without considering the subsequent increase in the billing rates.

**III. Transportation (Fixed rate on rental basis)**

The vehicles provided by the Consultants shall include the cost for rental, drivers, operation, maintenance, repairs, insurance, etc. for all complete approx. 4000km/month run. (The vehicles shall not be more than 3 years old.)

The requirement of vehicles be assessed and details provided in the table below:

**Requirements**

S. No	Description of Vehicles	Qty. (No. of vehicle- month)	Rate/ Vehicle-Month	Amount
1.	Team Leader Office - Innova/scorpio or equivalent	1 x 36		
2.	Support staff - Tata Sumo or Equivalent	4 x 36		
	Total	180		

**IV. Duty Travel to Site (Fixed Costs): Professional and Sub-Professional Staff**

Trips	Number of Trips	Rate*	Amount
Site to NHAI HQ/RO office and back for key personnel	36		
Site to NHAI HQ/RO office and back for sub-professional staff	18		

\*Rate quoted includes Hotel charges (lodging & boarding), travel cost etc. complete for one person.

#### V. Office Rent (Fixed Costs) - Minimum 200 sqm area of office shall be rented.

The office shall be located at Tirunelveli and the office rent includes electricity and water charges, maintenance, cleaning, repairs, security etc. complete.

Nos of Months	Rate/month	Amount
36		

#### VI. Office Supplies, Utilities and Communication (Fixed Costs)

The cost shall include of office supplies, drafting supplies, computer running cost, domestic and international communication etc. as required for office functioning.

Nos of Months	Rate/month	Amount
36		

#### VII. Office Furniture and Equipment (Rental)

The cost shall include rental charges towards all such furniture and equipment as required for proper functioning of the office. Office furniture shall include executive tables, chairs, visitor chairs, steel almirahs, computer furniture, conference table etc. Office equipment shall include as a minimum of telephone (2 external & 10 internal lines), photocopier (15ppm, 12000 copies per month with A3 & A4 input) fax machine, PCs (5 No., Intel Core 2 Duo E8300, 19" colour TFT, Cache - 6MB, RAM - 2 GB, HDD - 250 GB, DVD Writer, Key board, optical scroll mouse, MS- Windows Vista Business, pre loaded anti virus etc.), laser printers(2 no., 14 ppm, 266 MHz, 5000 pages per month, 600 x 600 dpi or better etc., Engineering Plan printer(1 no.), binding machine(1 no.), plotter A0 size, overhead projector, AC(4 no., 1.5 Ton), Water Coolers (as required) etc.

Nos of Months	Rate/month	Amount
36		

#### VIII. Reports and Document Printing

No.	Description	No. of Reports	No. of Copies per Report	Total Nos. of copies	Rate per Copy (Rs.)	Amount
1	Monthly reports	36	3	108		
2	Half yearly Reports	6	3	18		
3	Various others reports as provided in the Contract Agreement	30	3	90		
	<b>Total</b>					

All reports are to be provided in electronic form/soft copy also

#### **IX. Road Survey Equipment**

The cost shall include carrying out survey using equipment, manpower, software and report processing.

Item	Kms	Rate per km (INR)	No of times survey to be conducted	Amount (INR)
Surface defects detection and roughness measurement using network survey vehicle			6	
Pavement strength measurement using FWD			3	
Bridge inspection using mobile bridge inspection unit			6	
Road signs inspection using Retro Reflectometer			6	
Traffic sampling using ATCC			6	
<b>Total</b>				

## SECTION 6. TERMS OF REFERENCE FOR SUPERVISION CONSULTANT

### 1. Scope

- 1.1 These Terms of Reference for the Supervision Consultant(the “TOR”) are being specified pursuant to the Contract Agreement dated 10.04.2013 (the “Agreement”), which has been entered into between the Authority and M/s. RAIMA Toll Road Private Limited (the “Concessionaire”) for Operation & Maintenance Period of 4 laning of Madurai – Tirunelveli – Panagudi – Kanniyakumari Section from Km 0/000 to Km 243/170 on OMT Basis and Concession Agreement dated 20.05.2016, which has been entered into between the Authority and Shri. Rajagopal (O & M Contractor) 4 Laning and Strengthening of Existing 2 Lanes of Tirunelveli – Tuticorin Road from Km 4/300 to Km 51/200 of NH-7A in the State of Tamil Nadu and a copy of which is annexed hereto and marked as Annex-A to form part of this TOR.

S. No.	Consultancy Package	NH No.	Project Stretch	Project Length (Km) / Total Project Cost (Cr.)
	Supervision Consultant Services during Operation & Maintenance of following project in State of Tamil Nadu			
1	Operation & Maintenance of 4 laning of Madurai – Tirunelveli – Panagudi – Kanniyakumari Section from Km 0/000 to Km 243/170 of NH-7 (New NH.44) including construction of Bridge at Narikulam Tank Portion at km 230/700 to Km 231/250 and Improvement of Approach Road to ROB at Km 0/600 at Samayanallur of NH-7(New NH.44) and Operation & Maintenance of Tuticorin – Tirunelveli Section from Km 0/000 to km 47/250 of NH-7A (New NH.138) in the State of Tamil Nadu (2 <sup>nd</sup> Call)	7 (New NH.44 & 7A New NH.138)	Madurai – Kanniyakumari Section.  Tuticorin to Tirunelveli Section	243.170  47.250

## **2. Definitions and interpretation**

- 2.1 The words and expressions beginning with or in capital letters used in this TOR and not defined herein but defined in the Agreement shall have, unless repugnant to the context, the meaning respectively assigned to them in the Agreement.
- 2.2 References to Articles, Clauses and Schedules in this TOR shall, except where the context otherwise requires, be deemed to be references to the Articles, Clauses and Schedules of the Agreement, and references to Paragraphs shall be deemed to be references to Paragraphs of this TOR.
- 2.3 The rules of interpretation stated in Clauses 1.2, 1.3 and 1.4 of the Agreement shall apply, mutatis mutandis, to this TOR.

## **3. Role and functions of the Supervision Consultant**

3.1 The role and functions of the Supervision Consultant shall include the following:

- i. Survey (Including Traffic Survey) and examination of stretch for requirements of additional structures, project facilities, road furniture's and other items warranted for implementation including structural designs
- ii. Pavement condition survey for the entire stretch for the entire including plan and profile and working out required pavement strengthening measures and improvements
- iii. Condition survey of all existing structures and working out strengthening measures.
- iv. Cost valuation of proposed items/works after conducting survey examination of complete stretch
- v. Preparation of RFP document
- vi. Review of the Drawings and documents as set forth in Para 4;
- vii. Determine the Project facilities completion schedule
- iii. Review, inspection and monitoring of Construction Works as set forth in Paragraph 5;
- iv. Conducting tests on completion of construction and issuing Completion Certificate as set forth in Paragraph 5;
- v. Review, inspection and monitoring of O&M as set forth in Paragraph 6;

- vi. Review, inspection and monitoring of Divestment Requirements as set forth in Paragraph 7;
- vii. Determining, as required under the Agreement, the costs of any works or services and/or their reasonableness;
- viii. Determining, as required under the Agreement, the period or any extension thereof, for performing any duty or obligation;
- ix. providing all requisite data on monthly basis in Monthly Progress Report (MPR) within a period of 7 days from the close of month, as required by Authority, for updating the project specific website and PMIS substantially in the format prescribed at Annexure - III.
- x. Assisting the Parties in resolution of disputes as set forth in Paragraph 9; and
- xi. carrying out minor design works such as design of drainage, blackspot removal design, etc as per the requirements; and
- xii. Undertaking all other duties and functions in accordance with the Agreement.
- xviii. Provide assistance in dealing dispute resolution/arbitration case/court case pertain to the project highway even from the commencement of construction of the (4 lane) project.
- xix. To perform the function/duties as directed by the PIU/Authority for the project stretch without any additional cost.

3.2 The Supervision Consultant shall discharge its duties in a fair, impartial and efficient manner, consistent with the highest standards of professional integrity and Good Industry Practice.

3.3 The Supervision Consultant shall also perform following functions.

- i. to take measurements and keep measurement records, as per direction of NHAI.
- ii. to recommend issue of interim certificates for progress payments within 14 days of the receipt of bill. If the Project Director is satisfied about inordinate delay on part of Supervision Consultant, a penalty of Rs. 10,000/- or 0.5% of the monthly amount payable to the Supervision Consultant whichever is higher shall be levied on this account.
- iii. to maintain records, test data, details of variations, correspondence and diaries in the formats approved / specified by the Employer;

- 
- iv. to examine and attend the measurement of any work which is about to be covered up or put out of view before permanent work is placed thereon and / or examined and attend the measurement of the completed works in the prescribed form;
  - v. to check the contractor's accounts, invoices, and other statements as regards arithmetical errors and compliance with contract and if required, to make corrections thereof;
  - vi. to maintain a day-to-day diary which shall record all events pertaining to the administration of the Contract, request forms and orders given to the contractor and any other information which may at a later date be of assistance in resolving queries which may arise concerning execution of the works;
  - vii. to submit the specific reasons for negative/ positive variations in the various items of the BOQ
  - viii. to prepare BOQ along with estimate and rate analysis based on the surveys/ studies/audits for the future O&M contract and additional project facilities in consultation with clients representatives and submit it to the NHAI, HQ at least 4 months before the expiry of the contract. Consultant should submit three copies for the BOQ.
  - ix. Supervising the obligation of the Toll Collection agency including verifying the toll collection and other mandatory requirements as per contract with toll collection agency.
  - x. The hiring cost of equipments and all other ancillary items shall be part of the contract price for the obligations of supervision consultant under Clause 3.

#### 4. Review of Drawings and Documents

- 4.1 The Supervision Consultant shall undertake a detailed review of the Drawings to be furnished by the Contractor along with supporting data, including the geo-technical and hydrological investigations, characteristics of materials from borrow areas and quarry sites, topographical surveys and traffic surveys. The Supervision Consultant shall complete such review and send its comments/observations to the Authority and the Contractor within 15 (fifteen) days of receipt of such Drawings. In particular, such comments shall specify the conformity or otherwise of such Drawings with the Scope of the Project and Specifications and Standards (if required).
- 4.2 The Supervision Consultant shall review any modified Drawings or supporting Documents sent to it by the Contractor and furnish its comments within 7 (seven) days of receiving such Drawings or Documents.
- 4.3 The Supervision Consultant shall review the Drawings sent to it by the Safety Consultant in accordance with Schedule-H and furnish its comments thereon to the Authority and the Contractor within 7 (seven) days of receiving such Drawings. The Supervision Consultant shall also review the Safety Report and furnish its comments thereon to the Authority within 15 (fifteen) days of receiving such report.

#### 5. Construction Works

- 5.1 In respect of the Drawings, Documents and Safety Report received by the Supervision Consultant for its review and comments relating to the Construction Works, the provisions of Paragraph 4 shall apply, mutatis mutandis.
- 5.2 The Supervision Consultant shall review the monthly progress report furnished by the Contractor and send its comments thereon to the Authority and the Contractor within 7 (seven) days of receipt of such report.
- 5.3 The Supervision Consultant shall inspect the Construction Works and the Project Highway once every month, preferably after receipt of the monthly progress report from the Contractor, but before the 20<sup>th</sup> (twentieth) day of each month in any case, and make out a report of such inspection (the “**Inspection Report**”) setting forth an overview of the status, progress, quality and safety of construction, including the work methodology adopted, the materials used and their sources, and conformity of Construction Works with the Scope of the Project and the Specifications and Standards. In a separate section of the Inspection Report, the Supervision Consultant shall describe in reasonable detail the lapses, defects or deficiencies observed by it in the construction of the Project Facilities. The Inspection Report shall also contain a review of the maintenance of the existing lanes in conformity with the provisions of

- the Agreement. The Supervision Consultant shall send a copy of its Inspection Report to the Authority and the Contractor within 7 (seven) days of the inspection.
- 5.4 The Supervision Consultant may inspect the Project Highway more than once in a month if any lapses, defects or deficiencies require such inspections.
- 5.5 For determining that the Construction Works conform to Specifications and Standards, the Supervision Consultant shall require the Contractor to carry out, or cause to be carried out, tests on a sample basis, to be specified by the Supervision Consultant in accordance with Good Industry Practice for quality assurance. For purpose of this Paragraph 5.5, the tests specified in the IRC Special Publication-11 (Handbook of Quality Control for Construction of Roads and Runways) and the Specifications for Road and Bridge Works issued by MoRT&H (the “**Quality Control Manuals**”) or any modification/substitution thereof shall be deemed to be tests conforming to Good Industry Practice for quality assurance. The Supervision Consultant shall issue necessary directions to the Contractor for ensuring that the tests are conducted in a fair and efficient manner, and shall monitor and review the results thereof.
- 5.6 The sample size of the tests to be specified by the Supervision Consultant under Paragraph 5.5 shall comprise 10% (ten per cent) of the quantity or number of tests prescribed for each category or type of tests in the Quality Control Manuals; provided that the Supervision Consultant may, for reasons to be recorded in writing, increase the aforesaid sample size by up to 10% (ten per cent) for certain categories or types of tests.
- 5.7 The timing of tests referred to in Paragraph 5.5, and the criteria for acceptance/rejection of their results shall be determined by the Supervision Consultant in accordance with the Quality Control Manuals. The tests shall be undertaken on a random sample basis and shall be in addition to, and independent of, the tests that may be carried out by the Contractor for its own quality assurance in accordance with Good Industry Practice.
- 5.8 In the event that the Contractor carries out any remedial works for removal or rectification of any defects or deficiencies, the Supervision Consultant shall require the Contractor to carry out, or cause to be carried out, tests to determine that such remedial works have brought the Construction Works into conformity with the Specifications and Standards, and the provisions of this Paragraph 5 shall apply to such tests.
- 5.9 In the event that the Contractor fails to achieve scheduled progress of the project, the Supervision Consultant shall undertake a review of the progress of construction and identify potential delays, if any. If the Supervision Consultant shall determine that completion of any work is not feasible within the time specified in the Agreement, it shall require the Contractor to indicate within 15 (fifteen) days the steps proposed to

be taken to expedite progress, and the period within which completion shall be achieved. Upon receipt of a report from the Contractor, the Supervision Consultant shall review the same and send its comments to the Authority and the Contractor forthwith.

- 5.10 If at any time during the Contract Period, the Supervision Consultant determines that the Contractor has not made adequate arrangements for the safety of workers and Users in the Contractor zone of construction or that any work is being carried out in a manner that threatens the safety of the workers and the Users, it shall make a recommendation to the Authority forthwith identifying the whole or part of the Construction Works that should be suspended for ensuring safety in respect thereof.
- 5.11 In the event that the Contractor carries out any remedial measures to secure the safety of suspended works and Users, it may, by notice in writing, require the Supervision Consultant to inspect such works, and within 3 (three) days of receiving such notice, the Supervision Consultant shall inspect the suspended works and make a report to the Authority forthwith recommending whether or not such suspension may be revoked by the Authority.
- 5.12 If suspension of Construction Works is for reasons not attributable to the Contractor, the Supervision Consultant shall determine the extension of dates set forth in the Project Facilities Completion Schedule, to which the Contractor is reasonably entitled, and shall notify the Authority and the Contractor of the same.
- 5.13 The Supervision Consultant shall issue a Completion Certificate upon completion of each Project Facility and Major Maintenance Work, if any, specified under and in accordance with this Agreement.
- 5.14 Upon reference from the Authority, the Supervision Consultant shall make a fair and reasonable assessment of the costs of providing information, works and services as directed by authority and certify the reasonableness of such costs for payment by the Authority to the Contractor.
- 5.15 The Supervision Consultant shall aid and advise the Contractor in preparing the Maintenance Manual.

## **6. Operation & Maintenance**

- 6.1 The Supervision Consultant shall review the annual Maintenance Programme furnished by the Contractor and send its comments thereon to the Authority and the Contractor within 15 (fifteen) days of receipt of the Maintenance Programme.

6.2 The Supervision Consultant shall review the monthly status report furnished by the Contractor and send its comments thereon to the Authority and the Contractor within 7 (seven) days of receipt of such report.

### 6.3 Visual Inspection of project highway

6.3.1 The Supervision Consultant shall carry out visual inspection of entire highway stretch as per the frequency defined in the following table

Nature of defect or deficiency	Frequency of inspection
<b>ROADS</b>	
<b>(a) Carriageway and paved shoulders</b>	
(i)	Breach or blockade Daily
(ii)	Pot holes Daily
(iii)	Cracking Weekly
(iv)	Rutting Weekly
(v)	Bleeding/skidding Weekly
(vi)	Ravelling/Stripping of bitumen surface Weekly
(vii)	Damage to pavement edges Weekly
(viii)	Removal of debris Daily
<b>(b) Hard/earth shoulders, side slopes, drains and culverts</b>	
(i)	Variation by more than 2% in the prescribed slope of camber/cross fall Weekly
(ii)	Edge drop at shoulders Weekly
(iii)	Variation by more than 15% in the prescribed side (embankment) slopes Weekly
(iv)	Rain cuts/gullies in slope Weekly
(v)	Damage to or silting of culverts and side drains during and immediately preceding the rainy season Weekly
(vi)	Desilting of drains in urban/semi-urban areas Daily

Nature of defect or deficiency		Frequency of inspection
<b>I</b>	<b>Road side furniture including road signs and pavement marking</b>	
(i)	Damage to shape or position; poor visibility or loss of retro-reflectivity	Daily
<b>(d)</b>	<b>Street lighting and telecom (ATMS)</b>	
(i)	Any major failure of the system	Daily
(ii)	Faults and minor failures	Daily
(iii)	Streetlight with Lux Meter	Weekly
<b>(e)</b>	<b>Trees and plantation</b>	
(i)	Obstruction in a minimum head-room of 5 m above carriageway or obstruction in visibility of road signs	Daily
(ii)	Deterioration in health of trees and bushes	Weekly
(iii)	Replacement of trees and bushes	Weekly
(iv)	Removal of vegetation affecting sight line and road structures	Weekly
<b>(f)</b>	<b>Rest areas/ Wayside Amenities</b>	
(i)	Cleaning of toilets	Daily
(ii)	Defects in electrical, water and sanitary installations	Daily
<b>(g)</b>	<b>Toll plaza[s]</b>	
(i)	Failure of toll collection equipment including ETC or lighting	Daily
(ii)	Damage to toll plaza	Weekly
<b>(h)</b>	<b>Other Project Facilities and Approach roads</b>	
(i)	Damage or deterioration in Approach Roads, -[pedestrian facilities, truck lay-bys, bus-bays, bus- shelters, cattle crossings, Traffic Aid Posts, Medical Aid Posts and other works]	Daily
<b>(j)</b>	<b>Incident Management</b>	

Nature of defect or deficiency		Frequency of inspection
(i)	Instances of Incident Management as reported including time of call, response time, services rendered and time of clearing of the Highway.	Daily
(ii)	List of the Incident Management Services rendered.	Weekly
<b>BRIDGES</b>		
<b>(a)</b>	<b>Superstructure of bridges</b>	
(i)	Cracks	Weekly
(ii)	Spalling/scaling	Weekly
<b>(b)</b>	<b>Foundations of bridges</b>	
(i)	Scouring and/or cavitation	Weekly
<b>I</b>	<b>Piers, abutments, return walls and wing walls of bridges</b>	
(i)	Cracks and damages including settlement and tilting	Weekly
<b>(d)</b>	<b>Bearings (metallic) of bridges</b>	
(i)	Deformation	Weekly
<b>(e)</b>	<b>Joints in bridges</b>	
(i)	Loosening and malfunctioning of joints	Weekly
<b>(f)</b>	<b>Other items relating to bridges</b>	
(i)	Deforming of pads in elastomeric bearings	Weekly
(ii)	Gathering of dirt in bearings and joints; or clogging of spouts, weep holes and vent-holes	Weekly
(iii)	Damage or deterioration in parapets and handrails	Weekly
(iv)	Rain-cuts or erosion of banks of the side slopes of approaches	Weekly
(v)	Damage to wearing coat	Weekly
(vi)	Damage or deterioration in approach slabs, pitching, apron, toes, floor or guide bunds	Weekly

Nature of defect or deficiency		Frequency of inspection
(vii)	Growth of vegetation affecting the structure or obstructing the waterway	Weekly

6.3.2 All elements which have daily inspection frequency shall be inspected weekly as well. Similarly, all elements which have weekly inspection frequency shall be inspected monthly as well.

6.3.3 Daily inspection report format and weekly inspection report format has been provided in Annexure I and II of this document respectively. Manpower which needs to conduct visual inspection and mode of reporting is defined in the following table.

Frequency of inspection	Inspection to be carried out by	Mode of reporting
Daily	Sub-professional staff	Soft copy by Email
Weekly	Key personnel	Soft copy by Email
Monthly	Key personnel	Hard copy and Soft copy

6.3.4 The Consultant shall also be responsible for inspection and monitoring of Wayside Amenities, ETC (Electronic Toll Collection), ATMS (Advanced Traffic Management System) and incident management.

6.3.5 High resolution photographs and video of the highway stretches having defects and/or deficiencies shall be submitted along with Weekly Inspection Report and Monthly Status Report. Summary of key observations around defects and deficiencies in highway stretch shall be reported in Monthly Progress Report and detailed inspection report shall be provided as Annexure to Monthly Progress Report.

#### 6.4 Road conditions surveys

6.4.1 The carrying out of condition surveys will be one of the most important and crucial field tasks under the project. The Supervision Consultant shall carry out condition surveys using equipment and following a frequency as defined under.

S No	Key metrics of Asset	Equipment to be used	Frequency of condition survey
1	Surface defects of pavement	Network Survey Vehicle (NSV)	At least twice a year (As per survey months defined for the state basis rainy season)
2	Roughness of pavement	Laser Profilometer	At least twice a year (As per survey months defined for the state basis rainy season)
3	Strength of pavement	Falling Weight Reflectometer (FWD)	At least once a year
4	Bridges	Mobile Bridge Inspection Unit (MBIU)	At least twice a year (As per survey months defined for the state basis rainy season)
5	Road signs& Road Markings	Retro-reflectometer	At least twice a year (As per survey months defined for the state basis rainy season)
6	Traffic Sampling & Video Recording	ATCC	At least twice a year (As per survey months)

The first equipment based inspection shall be conducted within 30 days of appointed date of the Supervision Consultant. The other inspections shall be conducted before and after the rainy seasons as per the schedule defined in Annexure IV, except for FWD testing which shall be conducted once a year.

Calibration of equipment, wherever needed, is required to be done in presence of Competent Authority. Once approval of equipment, the settings and a sample data set is provided by Competent Authority, network level data for entire project stretch can be collected. Month of survey for each state has been defined in Annexure IV of this document.

### 6.4.2 Measurement of pavement surface defects and roughness

- i. The Supervision Consultant shall use Network Survey Vehicles mounted with equipment such as Laser based automatic crack detection , laser profilometer, high resolution digital cameras for RoW and pavement, high accuracy DGPS receiver etc and in vehicle data processing software or better technology to accurately measure following pavement surface properties

Surface defect	Dimensions to be reported
Cracking	<ul style="list-style-type: none"> <li>• Length</li> <li>• Width</li> <li>• Depth</li> </ul>
Potholes	<ul style="list-style-type: none"> <li>• Area</li> <li>• Depth</li> </ul>
Raveling	<ul style="list-style-type: none"> <li>• Indicator</li> <li>• %</li> <li>• Area</li> </ul>
Rutting	<ul style="list-style-type: none"> <li>• Depth</li> <li>• Width</li> </ul>
Concrete Joint/ Faulting	<ul style="list-style-type: none"> <li>• Length</li> </ul>
Roughness	<ul style="list-style-type: none"> <li>• IRI in both wheel paths</li> </ul>

- ii. The following criteria shall be met by the process of defects detection
- Measurement of 3D road profile using such technologies as laser scanning or other proven technologies.
  - Ability to operate (collect data) at different speeds with a minimum speed of 40km/h.
  - Profile depth accuracy of 0.5mm
  - Capability for lane tracking to control driver wander' and ensure high repeatability of data between surveys.

- Measure at least 3.5m width of highway lane.
  - Transverse Profile including rut depth measurement of pavement surface widths of both carriageway and shoulders. The rut depth data must be convertible to different straightedge lengths (1.8m to 3.5m) and meet industry standards (ASTM E1703 / E1703M).
  - Pavement images with capability to automatically identify and rate distresses
  - Roughness measurement with outputs of both raw longitudinal profiles and International Roughness Index (IRI) calculation shall be reported at least 100m referenced to the preceding Location Reference Post (LRP). The roughness must meet ASTM-E950 (equivalent to Class I road profiler). The IRI shall be determined in both wheel paths.
  - Ability to record images at user-defined intervals (e.g. every 5, 10m, etc.)
  - Minimum images resolution of 1600x1200
  - Outputs must include Standard JPEG image or similar industry standard
  - Distance resolution of <1mm,
  - Capable of achieving distance accuracy of 0.1% (i.e. within 1m over 1km distance)
  - All data outputs should be in a non-proprietary format (e.g. .CSV, .MDB, Excel) and not require specialist software in order to view or format data
  - Data should also be capable of being easily formatted into data compatible with HDM-4
- iii. The following are the set of deliverables which should be submitted after completion of survey as part of Monthly Progress Report
- Raw data generated from the equipment which are part of Network Survey covering the parameters mentioned in above table. It should also include
    - Survey ID, Description, Date, Lane
    - GPS referenced data for GIS mapping
  - Video logging
    - Pavement imagery (AVI/JPEG)
    - 360 degree imagery (JPEG)
  - Interpretation report covering summary of entire survey and analysis of defects and deficiencies

### 6.4.3 Measurement of pavement strength

- i. The Supervision Consultant shall carry out structural strength surveys for existing pavements using Falling Weight Deflectometer technique in accordance with the procedure given in IRC:115-2014 (Guidelines for Structural Evaluation and Strengthening of Flexible Road Pavements Using Falling Weight Deflectometer (FWD) Technique) and IRC: 117-2015 (Guidelines for the Structural Evaluation of Rigid Pavement by Falling Weight Deflectometer)
  - ii. The interval at which deflection measurements are to be taken up are as per IRC:115-2014. For flexible pavements, the sample size and the interval of the data to be collected depends on the length of the uniform section calculated and condition of the pavement section i.e. 'good', 'fair' and 'poor' for each lane, established on the pavement condition data based on the criterion given in IRC:115-2014. For rigid pavements, the deflection data may be collected at interiors, corners, transverse joints and longitudinal joints in the outer lanes at intervals as specified in IRC:117-2015.
  - iii. The following are the set of deliverables which should be submitted after completion of inspection test as part of Monthly Progress Report
    - Data report covering following parameters
      - Deflection Bowl (Transient Deflections at seven different points)
      - Corrected Elastic Modulus Bituminous E1
      - Corrected Elastic Modulus Granular E2
      - Corrected Elastic Modulus Subgrade E3
      - Subgrade CBR
    - Interpretation report covering summary of entire survey results and analysis of key parameters
- 6.4.4 The Supervision Consultant shall carry out the condition and structural assessment survey of the bridges in accordance with IRC-SP; 35 with the use of Mobile Bridge Inspection unit (MBIU) or better technology.
- i. The following criteria shall be met by the process of bridge condition assessment
    - Automatic folding and unfolding of platform
    - 90 degree rotation of platform

- Sufficient safety features to be incorporated such as dedicated power supply, emergency cut off system, etc
  - Complete access to hidden parts of the bridge by the raters
- ii. Detailed bridge inspection report shall be submitted as per the Inspection Proforma provided in IRC-SP 35

#### 6.4.5 Measurement of retroreflection of road signs

- i. The Supervision Consultant shall measure Coefficient of retroreflected luminance  $R_A$  (nighttime retroreflection) of road traffic signs using a portable retroreflectometer.
- ii. The following criteria shall be met by the process of road signs retroreflection measurement
- Measurement of retroreflective signs shall be conducted in accordance with ASTM E1709 and ASTM E2540
  - Measurement time after pressing trigger shall be less than or equal to 1 sec
  - Observation angle adjustment from 0.2 degrees to 2.0 degrees
  - Entrance angle adjustment from -45 degrees to +45 degrees
  - Self-contained commercially available battery
  - Inbuilt data storage of at least 2,000 measurements so that data transfer requirement is minimized while the survey is being conducted
  - Interface for transferring data from device to Computer
  - Built in GPS to capture GPS coordinates of road sign
  - Range shall be at least 0-2000 cd/lx/m<sup>2</sup>
- iii. The following are the set of deliverables which should be submitted after completion of survey as part of Monthly Progress Report
- System generated coefficient of retroreflected luminance  $R_A$  (nighttime retroreflection) of all road signs
  - Interpretation report covering analysis of road signs falling in different range of  $R_A$  and actions to be taken

#### 6.4.6 Performance Assessment of Road Markings

Road Markings shall be subjected to routine inspection in accordance with the inspection methods set out in IRC:35-2015 in respect of following:

Retro-reflectivity Dry and Wet ( $R_L$  and  $R_W$ )

Wear (W)

Luminance coefficient ( $Q_d$ )

Skid resistance (SRT)

#### 6.4.7 Traffic sampling and video recording

- i. Consultant shall use ATCC systems that can meet the following accuracy levels after validation/ calibration:
  - a) Classification of vehicles: better than 95%
  - b) Counting of vehicles: better than 98%

Before validation and calibration, the ATCC system shall meet the following accuracy levels:

- a) Classification of vehicles: better than 90%
- b) Counting of vehicles: better than 95%

For verification of above accuracy levels, audit of raw ATCC shall be done by the consultant on a sampling basis and should submit a certificate in this regard.

- ii. ATCC systems such as Pneumatic Tube Detector, Inductive Detector Loop, Video Image Detection, and Infrared Sensor or latest technologies shall be adopted.
- iii. The classified traffic volume count surveys shall be carried out for 7 days (continuous, direction-wise) at the selected survey stations. The vehicle classification system as given in relevant IRC code may be followed. However, the following generalized classification system is suggested in view of the requirements of traffic demand estimates and economic analysis:

Motorised Traffic		Non-Motorised Traffic
2-Wheeler		Bi-Cycle
3-Wheeler		Cycle-Rickshaw
Passenger Car		Animal Drawn Vehicle(ADV)
Utility Vehicle (Jeep, Van etc.)		Hand Cart
		Other Non-Motorised Vehicle
Bus	Mini Bus Standard Bus	
LCV	LCV-Passenger LCV-Freight	
Truck	MCV : 2-Axle Rigid Chassis	
	HCV : 3-Axle Rigid Chassis	

	MAV	Semi Articulated	
		Articulated	

- iv. All results shall be presented in tabular and graphical form. The survey data shall be analyzed to bring out the hourly and daily variations. The traffic volume count per day shall be averaged to show a weekly average daily traffic (ADT) by vehicle type. The annual average daily traffic (AADT) shall be worked out by applying seasonal factors.

6.5 The Supervision Consultant shall carry out following inspections of ETC lanes at toll plazas on a month basis:

**12. Infrastructure:**

- *Availability of civil infrastructure at toll plazas required for installation of ETC systems*
- *Adequacy of hardware, software and other related items as per IHMCL/NHAI technical specifications and requirements*

**13. Operations:**

- *Adherence of various stakeholders (acquirer bank, system integrator, toll operator, issuer bank etc) of the ETC system to the service level agreements*
- *Efficacy of the ETC system (RFID tagging, AVC, WIM etc) in terms of accuracy and uptime*
- *Tracking and reporting toll plaza experience metrics such as average waiting time, transaction times for different modes of payment (RFID, cash, smart cards, QR codes etc) and congestion levels (eg length of queue in different lanes) across 4 different times in a day*
- *Robustness of dispute resolution mechanisms in place for the tag holder and toll operators by the issuer and acquirer banks*

6.6 The Supervision Consultant shall prepare a Monthly Status Report in respect of its duties and functions under this Agreement and in accordance with the format prescribed in Annexure III. 1<sup>st</sup> deliverable of the report which is an executive summary to the main report (Section 1) shall be submitted to the Authority and updated on the PMIS and project specific website by 4<sup>th</sup> of every month. Main report (Section 2 onwards) shall be submitted to the Authority and updated on the PMIS and project specific website by 7<sup>th</sup> of every month. Key sections of the Monthly Status Report are as follows.

S.No	Sections	Sub sections
1	Executive Summary	1.1 Overall road condition
		1.2 Key reporting metrics

S.No	Sections	Sub sections
		1.3 Key maintenance activities undertaken 1.4 Pending issues 1.5 Recommended actions by IE/SC 1.6 Strip plan for maintenance
2	Project Overview	2.1 Key project details 2.2 Location map 2.3 Key plan 2.4 Summary of project features 2.5 RoW availability
3	Critical issues and action taken	3.1 Issue and action log 3.2 Summary of deficiencies 3.3 Obligations as per contract 3.4 Inspection schedule
4	Monthly Inspection Report	4.1 Summary of NCR issued 4.2 Equipment based inspection report
5	Monitoring of ETC lanes	5.1 Monthly ETC Report 5.2 On-ground infrastructure report 5.3 On-ground ETC operations & SLA adherence
6	Status of damages	6.1 Damages for non completion of project facilities 6.2 Damages for breach of maintenance activities 6.3 Damages for non completion of major maintenance works

<b>S.No</b>	<b>Sections</b>	<b>Sub sections</b>
<b>7</b>	<b>Change of Scope proposals</b>	7.1 Change of Scope proposals
<b>8</b>	<b>Status of pending disputes</b>	8.1 Status of pending disputes
<b>9</b>	<b>Reports</b>	9.1 Toll collection statement
		9.2 Accident Report
		9.3 Details of user complaints
		9.4 Encroachment list
		9.5 Lane closure report
<b>10</b>	<b>Annexures</b>	

- 6.7 The Supervision Consultant shall in its O&M Inspection Report specify the tests, if any, that the Contractor shall carry out or cause to be carried out for the purpose of determining that the Project Highway is in conformity with the Maintenance Requirements. It shall monitor and review the results of such tests and the remedial measures, if any, taken by the Contractor in this behalf.
- 6.8 In respect of any defect or deficiency referred to in Paragraph 3 of Schedule-K, the Supervision Consultant shall, in conformity with Good Industry Practice, specify the permissible limit of deviation or deterioration with reference to the Specifications and Standards and shall also specify the time limit for repair or rectification of any deviation or deterioration beyond the permissible limit.
- 6.9 The Supervision Consultant shall determine if any delay has occurred in completion of repair or remedial works in accordance with the Agreement, and shall also determine the Damages, if any payable by the Contractor to the Authority for such delay.
- 6.10 The Supervision Consultant shall examine the request of the Contractor for closure of any lane(s) of the carriageway for undertaking maintenance/repair thereof, keeping in view the need to minimize disruption in traffic and the time required for completing such maintenance/repair in accordance with Good Industry Practice. It shall grant permission with such modifications, as it may deem necessary, within 3 (three) days of receiving a request from the Contractor. Upon expiry of the permitted period of closure, the Supervision Consultant shall monitor the re-opening of such lane(s), and in case of delay, determine the Damages payable by the Contractor to the Authority as per Contract Agreement.

- 6.11 The Supervision Consultant shall monitor and review the curing of defects and deficiencies by the Contractor as per Contract Agreement.
- 6.12 In the event that the Contractor notifies the Supervision Consultant of any modifications that it proposes to make to the Project Highway, the Supervision Consultant shall review the same and send its comments to the Authority and the Contractor within 15 (fifteen) days of receiving the proposal.
- 6.13 On requirement, the Supervision Consultant shall carry out minor design works such as design of drainage, blackspot removal design, etc
- 6.14 The Supervision Consultant shall undertake traffic sampling, as and when required by the Authority.

#### **14. Termination**

- 7.1 At any time, not earlier than 90 (ninety) days prior to Termination but not later than 15 (fifteen) days prior to such Termination, the Supervision Consultant shall, in the presence of a representative of the Contractor, inspect the Project Highway for determining compliance by the Contractor and, if required, cause tests to be carried out at the Contractor's cost for determining such compliance.
- 7.2 The Supervision Consultant shall inspect the Project Highway once in every 15 (fifteen) days during a period of 90 (ninety) days after Termination for determining the liability of the Contractor in respect of the defects or deficiencies specified therein. If any such defect or deficiency is found by the Supervision Consultant, it shall make a report in reasonable detail and send it forthwith to the Authority and the Contractor.

#### **15. Determination of costs and time**

- 8.1 The Supervision Consultant shall determine the costs, and/or their reasonableness, that are required to be determined by it under the Agreement.
- 8.2 The Supervision Consultant shall determine the period, or any extension thereof, that is required to be determined by it under the Agreement

#### **16. Assistance in Dispute resolution**

- 9.1 When called upon by either Party in the event of any Dispute, the Supervision Consultant shall mediate and assist the Parties in arriving at an amicable settlement.
- 9.2 In the event of any disagreement between the Parties regarding the meaning, scope and nature of Good Industry Practice as set forth in any provision of the Agreement, the Supervision Consultant shall specify such meaning, scope and nature by issuing a reasoned written statement relying on good industry practice and authentic literature.

**17. Other duties and functions**

10.1 The Supervision Consultant shall perform all other duties and functions specified in the Agreement.

**18. Miscellaneous**

11.1 All key personnel and sub professional staff of the Supervision Consultant shall use the fingerprint based (biometric) attendance system for marking their daily attendance. Attendance shall be marked at least once a day and anytime during the day. 1 Biometric Attendance System shall be installed by the Supervision Consultant at its own cost at the site office in order to facilitate the attendance marking. More systems can be installed near the project highway up to a maximum of 1 system per 50 km in order to encourage frequent visits of project highway by key personnel and sub professional staff. A copy of monthly attendance records shall be attached with Monthly Status Report. Proper justification shall be provided for cases of absence of key personnel/ sub professional staff which do not have prior approval from Project Director of concerned stretch.

11.2 The Supervision Consultant shall notify its programme of inspection to the Authority and to the Contractor, who may, in their discretion, depute their respective representatives to be present during the inspection.

11.3 A copy of all communications, comments, instructions, Drawings or Documents sent by Supervision Consultant to the Contractor pursuant to this TOR, and a copy of all the test results with comments of the Supervision Consultant thereon shall be furnished by the Supervision Consultant to the Authority forthwith.

11.4 The Supervision Consultant shall obtain, and the Contractor shall furnish in two copies thereof, all communications and reports required to be submitted under this Agreement by the Contractor to the Supervision Consultant, whereupon the Supervision Consultant shall send one of the copies to the Authority along with its comments thereon.

11.5 The Supervision Consultant shall retain at least one copy each of all Drawings and Documents received by it, including 'as-built' Drawings and keep in its safe custody.

11.6 Upon completion of its assignment hereunder, the Supervision Consultant shall duly classify and list all Drawings, Documents, results of tests and other relevant records, and hand them over to the Authority or such other person as the Authority may specify, and obtain written receipt thereof. Two copies of the said documents shall also be furnished in micro film form or in such other medium as may be acceptable to the Authority.

**Enclosure-A****MAN - MONTHS INPUT FOR KEY PROFESSIONAL STAFF SUPERVISION  
CONSULTANT**

	<b>(A) Key Personnel (Professional Staff)</b>	<b>Man Month</b>
1	Team Leader cum Sr. Highway Engineer	1 x 36
2	Highway Maintenance cum Resident Engineer	3 x 36
3	Road Safety Expert	1 x 9
4	Bridge/Structural Engineer	1 x 14
	<b>Sub - Total</b>	<b>167</b>
	<b>Sub-professional</b>	
1	Assistant Highway Maintenance Engineer	5 x 36
2	Assistant Quality material Engineer	2 X 36
3	Assistant Bridge Engineer	2 X 24
4	CAD Expert	1 x 10
5	Electrical Engineer	1 x 7
6	Horticulture Expert	1 x 36
7	Quantity Surveyor	2 X 36
8	IT Expert	5 X 36
	<b>Sub- Total</b>	<b>605</b>

**Note:**

1. The Team Leader may not be required every day as they handle assignments on other projects also running concurrently. However, their presence would be required at least for a week every month. The man-months for the Team Leader have been indicated accordingly.
2. The Contract Specialist and Financial Analyst may be required for the project for specific needs. Their deployment shall be arranged by the consultant on specific requisition from the Authority and the payment shall be made as per the actual deployment. The Contract Specialist and Financial Analyst shall be paid at the average of the rates quoted for Key Personnel listed at Sl. No. 2, 3 & 4 above.
3. The qualification and experience of Sub Professional staff would not be accounted in the evaluation. However, Consultant shall have to get their CVs approved from NHAI

before mobilization. The other inputs like support staff shall also be provided by the Consultant of an acceptable type commensurating with the roles and responsibilities of each position.

4. The S. No. 2,3,7,8,of sub professional staff will be mobilized as per requirement of PIU, Madurai.

## Enclosure B

### MINIMUM QUALIFICATION OF

#### KEY PERSONNEL & SUB PROFESSIONAL STAFF QUALIFICATION OF KEY PERSONNEL

##### TEAM LEADER CUM Sr. HIGHWAY ENGINEER

This is the senior most position and the expert engaged as the team leader shall be responsible for reviewing the entire Project implementation activities of the Contractor. He shall check all the Designs being prepared by the Contractor, ensure execution of works on site as per specification and standards, and continuously interact with the NHA and the Contractor. He shall review and suggest modifications to the Maintenance Manual, Annual Maintenance Programme of the Contractor. Review of emergency response arrangements needs special attention. He shall undertake Project site visits and shall guide, supervise, coordinate and monitor the work of other experts in his team as well as those of the Contractor. The candidate is required to be a Highway Engineer, who should have a proven record of supervising, organising and managing of Project preparation w.r.t construction/maintenance of highway projects as defined below, financed by international lending agencies and others.

He should have the following qualification / experience.

#### 1. Essential Qualifications.

- i. Graduate in Civil Engineering from recognized university.
- ii. Total Highway Experience of 10 years.
- iii. At least 3 years experience as Team Leader/Project Manager or in similar capacity in O&M and other related activities (like Maintenance Manual, Maintenance Programmes, Lane Closures, Traffic Management, etc.) of completed 4/6 lane highway sections.

#### 2. Preferential Qualifications.

- i. Post Graduate Degree in Management/ Construction/ Transportation/ Highway Engineering/ Structural Engineering or any other specialized stream of civil engineering.
- ii. Highway Development Projects taken up under EPC.

**Note:** (1) Similar Capacity includes the following positions

- On behalf of Consultant: Team Leader/Resident Engineer(Construction Supervision/IE)
- a) On behalf of Contractor: Project Manager(Construction/Construction Supervision)
- b) In Government Organizations: Superintending Engineer (or equivalent) and above

In case of experience on behalf of Consultant or Contractor, the experience shall be duly endorsed by the respective Government agency. In case of non-availability of endorsement

from Govt. Agency, the experience uploaded on Infracon Portal will be taken into consideration. However, the key personnel/ bidder will be solely responsible for any fake information/ CV, which may result in debarment.

- (2) Only those projects will be considered for evaluation where the input of the personnel is 9 months or more.

### **HIGHWAY MAINTENANCE cum RESIDENT ENGINEER**

The Highway Engineer shall be responsible for undertaking routine/periodic inspection of Project Highway and supervision of construction/ O&M works. His expertise shall include pavement conditions surveys, data collection, computer aided design methods for Civil/Highway Engineering with particular reference to CAD application to the highway rehabilitation and/or upgrading projects. All CD works shall be inspected by him at least once before and after monsoon so as to see that the vent way is clear and protection works are intact.

He should have the following qualification / experience.

#### **1. Essential Qualifications.**

- i. Graduate in Civil Engineering from a recognized University.
- ii. Professional Experience of 7 years in highway works (inspection/design/construction/maintenance).
- iii. Experience of at least 3 years in similar capacity in Highway Construction/Maintenance works of similar nature
- iv. Out of 3 years as in (iii) above at least one project should involve works of 4/6 laning/expressways or similar project

#### **2. Preferential Qualifications.**

- i. Post Graduate Degree in Highway Engineering

**Note:** Similar Capacity includes the following positions

- i. On behalf of Consultant: Highway Engineer/ Highway Maintenance Engineer/ Resident Engineer (Construction Supervision/IE)
- ii. On behalf of Contractor: Highway Engineer / Project Manager (Construction/Construction Supervision)
- iii. In Government Organizations: Executive Engineer (or equivalent) and above

In case of experience on behalf of Consultant or Contractor, the experience shall be duly endorsed by the respective Government agency. In case of non-availability of endorsement from Govt. Agency, the experience uploaded on Infracon Portal will be taken into consideration. However, the key personnel/ bidder will be solely responsible for any fake information/ CV, which may result in debarment.

**BRIDGE / STRUCTURAL ENGINEER**

The Bridge Engineer shall be responsible for supervising the works of existing or proposed bridges, interchanges and any other structure related to the Project Highway. He shall undertake structure condition survey once in a year and submit an exclusive report on repair and rehabilitation requirements of bridges/ structures. He shall also inspect the bridge rehabilitation and repair works which are required to be undertaken by the Contractor. He shall review and suggest modifications to the maintenance manual/programme relating to his duties.

He should have the following qualification / experience.

**1. Essential Qualifications.**

- i. Graduate in Civil Engineering from a recognized University.
- ii. Professional Experience of 7 years.
- iii. 3 years experience in similar capacity in Construction / Construction Supervision of bridge / interchange / any other Structures including rehabilitation
- iv. At least one project should involve work of 4/6 laning/expressways or similar project.

**2. Preferential Qualifications.**

- i. Post Graduate Degree in Structural Engineering.

**Note-** Similar Capacity includes the following positions

- i. On behalf of Consultant: Bridge Engineer/ Bridge Design Engineer/ Structural Engineer
- ii. On behalf of Contractor: Bridge Engineer/ Bridge Design Engineer/ Structural Engineer
- iii. In Government Organizations: Executive Engineer (or equivalent)and above

In case of experience on behalf of Consultant or Contractor, the experience shall be duly endorsed by the respective Government agency. In case of non-availability of endorsement from Govt. Agency, the experience uploaded on Infracon Portal will be taken into consideration. However, the key personnel/ bidder will be solely responsible for any fake information/ CV, which may result in debarment.

**ROAD SAFETY EXPERT**

The Road Safety Expert shall review all the safety measures taken by the Contractor during the contract period at site. Conformity to the safety requirement as per detailed contract requirement shall also be checked and approved. This shall cover all the temporary/permanent structures, handling of equipments, safety of workers/road users and generating awareness /training of site staff of Contractor. He shall also look into the causes of various accidents and review other insurance coverage taken by the Contractor.

He shall undertake, supervise safety audit/ inspection once in every quarter and furnish a detailed report. He shall review emergency response arrangement, accident data, formats, safety provisions in O&M activities etc., as proposed by the Contractor.

**1. Essential Qualifications.**

- i. Graduate in Civil Engineering from a recognized University.
- ii. Professional Experience of 7 years.
- iii. Minimum 3 years experience in Road Safety works of Major Highway Projects (4 / 6laning projects)
- iv. Experience in Road Safety Audit of at least one 4/6 lane highway / expressway project.

**2. Preferential Qualifications**

- i. Post Graduate Degree in Traffic/Transportation/Safety Engineering.
- ii. Preparation of Road Safety Management Plan for inter urban Highways in EPC mode.

**Note-** Similar Capacity includes the following positions

- i. On behalf of Consultant: Road Safety Expert (Construction Supervision/IE)
- ii. On behalf of Contractor: Road safety Expert (Construction/Construction Supervision)
- iii. In Government Organizations: Executive Engineer (or equivalent)and above

In case of experience on behalf of Consultant or Contractor, the experience shall be duly endorsed by the respective Government agency. In case of non-availability of endorsement from Govt. Agency, the experience uploaded on Infracon Portal will be taken into consideration. However, the key personnel/ bidder will be solely responsible for any fake information/ CV, which may result in debarment.

---

## SUB PROFESSIONAL

### **ASSISTANT HIGHWAY MAINTENANCE ENGINEER:**

The Candidate should be either Graduate in Civil Engineering with 3 years experience in highways or Diploma in Civil Engineering with 7 years experience in highways. He should have handled at least one highway project of similar nature.

### **ASSISTANT QUALITY CUM MATERIAL ENGINEER:**

The Candidate should be either Graduate in Civil Engineering with 3 years experience in highways or Diploma in Civil Engineering with 5 years experience in highways. He should have handled at least one highway project of similar nature.

### **ASSISTANT BRIDGE ENGINEER:**

The Candidate should be either Graduate in Civil Engineering with 3 years experience in highways or Diploma in Civil Engineering with 10 years experience in highways. He should have handled at least one Major Bridge project.

### **CAD EXPERT:**

He should be a Graduate in Civil Engineering with adequate computer training or graduate in Computer Science having experience in computer aided design methods in highway engineering. The incumbent should have 3 years experience and should have handled at least one highway project of similar nature.

### **ELECTRICAL ENGINEER:**

The Candidate should be a Graduate in Electrical Engineering. He should have at least 6 years professional experience.

### **HORTICULTURE EXPERT:**

The Candidate should be a Graduate in Agriculture Science with specialization in Horticulture/Arboriculture. He should have at least 6 years professional experience.

### **QUANTITY SURVEYOR:**

He should be Graduate or equivalent in Civil Engineering having Min. 5 years of professional experience in preparation of highway project estimates. He should have Min. 3 years experience in Preparation of Bill of Quantities/estimates for major highway projects costing Rs.100 Crore or above.

### **IT EXPERT:**

**Duties:** He shall be assisting the Team Leader. He is proposed to be deployed during the construction period as well as in defect liability period for some duration to assist the Team

Leader in discharging all his day-to-day functions. His main responsibilities include designing of communication system layout and safety security systems for TMS, HTMS, ATMS as well as all IT related works, besides discharging any other work assigned to him by the Team Leader. Such modifications will be required to be done on Software MOSS

**Qualification and Experience:** The candidate should be a Systems Engineer having experience of at least 5 years. He should be an expert in preparation of standards for systems of toll collection and HTMS. He should be a graduate in Electronics/Computer Science or equivalent. He should have experience of international latest technology/systems in the field of HTMS and tolling. He should have work experience of at least one in establishing HTMS as well as all IT related works and one in tolling systems.

**Note:** Upto 1 sub-professional can be a fresh graduate (zero/ less than minimum required work experience) with first class in graduation stream. Eligibility requirement in terms of minimum years of experience shall not be applicable for this sub professional.

### Annexure I- Daily Inspection Report

Nature of defect/ deficiency	Defect found (Yes/No)	If defect found, Chainage & side	Compliance of previous defect (Yes/No/NA)	SC Remarks
<b>ROADS</b>				
<b>Carriageway and paved shoulders</b>				
Breach or blockade				
Pot holes				
Removal of debris				
<b>Hard/earth shoulders, side slopes, drains and culverts</b>				
Desilting of drains in urban/semi-urban areas				
<b>Road side furniture including road signs and pavement marking</b>				

Nature of defect/ deficiency	Defect found (Yes/No)	If defect found, Chainage & side	Compliance of previous defect (Yes/No/NA)	SC Remarks
Damage to shape or position; poor visibility or loss of retro-reflectivity				
<b>Street lighting and telecom (ATMS)</b>				
Any major failure of the system				
Faults and minor failures				
<b>Trees and Plantation</b>				
Obstruction in a minimum head-room of 5 m above carriageway or obstruction in visibility of road signs				
<b>Rest areas</b>				
Cleaning of toilets				
Defects in electrical, water and sanitary installations				
<b>Toll plaza[s]</b>				
Failure of toll collection equipment including ETC or lighting				
<b>Other Project Facilities and Approach roads</b>				
Damage or deterioration in				

Nature of defect/ deficiency	Defect found (Yes/No)	If defect found, Chainage & side	Compliance of previous defect (Yes/No/NA)	SC Remarks
Approach Roads, -[pedestrian facilities, truck lay-bys, bus-bays, bus- shelters, cattle crossings, Traffic Aid Posts, Medical Aid Posts and other works]				

### Annexure II- Weekly Inspection Report

Nature of defect or deficiency		Defect found (Yes/No )	If defect found, Chainage & side	Compliance of previous defect (Yes/No/NA)	SC Remarks
<b>ROADS</b>					
<b>(a)</b>	<b>Carriageway and paved shoulders</b>				
(i)	Breach or blockade				
(ii)	Roughness value exceeding 2,500 mm in a stretch of 1 km (as measured by a standardised roughometer/bump integrator)				
(iii)	Pot holes				

Nature of defect or deficiency		Defect found (Yes/No)	If defect found, Chainage & side	Compliance of previous defect (Yes/No/NA)	SC Remarks
(iv)	Cracking in more than 5% of road surface in a stretch of 1 km				
(v)	Rutting exceeding 10 mm in more than 2% of road surface in a stretch of 1 km (measured with 3 m straight edge)				
(vi)	Bleeding/skidding				
(vii)	Ravelling/Stripping of bitumen surface exceeding 10 sq m				
(viii)	Damage to pavement edges exceeding 10 cm				
(ix)	Removal of debris				
<b>(b)</b>	<b>Hard/earth shoulders, side slopes, drains and culverts</b>				
(i)	Variation by more than 2% in the prescribed slope of camber/cross fall				
(ii)	Edge drop at shoulders exceeding 40 mm				
(iii)	Variation by more than 15% in the prescribed side (embankment) slopes				
(iv)	Rain cuts/gullies in slope				

Nature of defect or deficiency		Defect found (Yes/No)	If defect found, Chainage & side	Compliance of previous defect (Yes/No/NA)	SC Remarks
(v)	Damage to or silting of culverts and side drains during and immediately preceding the rainy season				
(vi)	Desilting of drains in urban/semi-urban areas				
(c)	<b>Road side furniture including road signs and pavement marking</b>				
(i)	Damage to shape or position; poor visibility or loss of retro-reflectivity				
(d)	<b>Street lighting and telecom (ATMS)</b>				
(i)	Any major failure of the system				
(ii)	Faults and minor failures				
(e)	<b>Trees and plantation</b>				
(i)	Obstruction in a minimum head-room of 5 m above carriageway or obstruction in visibility of road signs				
(ii)	Deterioration in health of trees and bushes				
(iii)	Replacement of trees and bushes				

Nature of defect or deficiency		Defect found (Yes/No)	If defect found, Chainage & side	Compliance of previous defect (Yes/No/NA)	SC Remarks
(iv)	Removal of vegetation affecting sight line and road structures				
<b>(f)</b>	<b>Rest areas</b>				
(i)	Cleaning of toilets				
(ii)	Defects in electrical, water and sanitary installations				
<b>(g)</b>	<b>Toll plaza[s]</b>				
(i)	Failure of toll collection equipment including ETC or lighting				
(ii)	Damage to toll plaza				
<b>(h)</b>	<b>Other Project Facilities and Approach roads</b>				
(i)	Damage or deterioration in Approach Roads, - [pedestrian facilities, truck lay-bys, bus-bays, bus-shelters, cattle crossings, Traffic Aid Posts, Medical Aid Posts and other works]				
<b>BRIDGES</b>					
<b>(a)</b>	<b>Superstructure of bridges</b>				
(i)	Cracks				

Nature of defect or deficiency		Defect found (Yes/No)	If defect found, Chainage & side	Compliance of previous defect (Yes/No/NA)	SC Remarks
(ii)	Spalling/scaling				
<b>(b)</b>	<b>Foundations of bridges</b>				
(i)	Scouring and/or cavitation				
<b>(c)</b>	<b>Piers, abutments, return walls and wing walls of bridges</b>				
(i)	Cracks and damages including settlement and tilting				
<b>(d)</b>	<b>Bearings (metallic) of bridges</b>				
(i)	Deformation				
<b>(e)</b>	<b>Joints in bridges</b>				
(i)	Loosening and malfunctioning of joints				
<b>(f)</b>	<b>Other items relating to bridges</b>				
(i)	Deforming of pads in elastomeric bearings				
(ii)	Gathering of dirt in bearings and joints; or clogging of spouts, weep holes and vent-holes				
(iii)	Damage or deterioration in parapets and handrails				

Nature of defect or deficiency		Defect found (Yes/No )	If defect found, Chainage & side	Compliance of previous defect (Yes/No/NA)	SC Remarks
(iv)	Rain-cuts or erosion of banks of the side slopes of approaches				
(v)	Damage to wearing coat				
(vi)	Damage or deterioration in approach slabs, pitching, apron, toes, floor or guide bunds				
(vii)	Growth of vegetation affecting the structure or obstructing the waterway				

### Annexure III- Monthly Status Report



सड़क परिवहन और राजमार्ग मंत्रालय  
**MINISTRY OF ROAD TRANSPORT & HIGHWAYS**  
भारत सरकार Government of India

[NAME & LOGO OF IMPLEMENTING AGENCY]

**[PROJECT NAME \*\*\*\*\*)]**

**Supervision Consultant**

**[NAME OF CONSULTING FIRM]**

**MONTHLY STATUS REPORT NO. [XX]**

**FOR THE MONTH OF: [MONTH], [YEAR]**

## Contents

1.	Executive Summary .....	112
1.1.	Overall road condition .....	112
1.2.	Key reporting metrics .....	112
1.3.	Key maintenance activities undertaken .....	112
1.4.	Pending issues .....	113
1.5.	Recommended actions by Supervision Consultant .....	113
1.6.	Strip Plan for maintenance .....	114
2.	Project Overview .....	115
2.1.	Key project details .....	115
2.2.	Location Map .....	116
2.3.	Key plan .....	117
2.4.	RoW availability .....	117
2.5.	Summary of project features .....	118
3.	Critical Issues and Action taken .....	119
3.1.	Issue and action log .....	119
3.2.	Summary of items (Cumulative Observations/ Deficiencies) .....	119
3.3.	Obligations as per contract.....	122
3.4.	Major maintenance and Inspection schedule .....	122
4.	Inspection Report.....	124
4.1.	Summary of NCR issued .....	124
4.2.	Equipment based inspection report .....	125
5.	Monitoring of ETC lanes.....	128
5.1.	Monthly ETC Report .....	128
5.2.	On-ground infrastructure report.....	128
5.3.	On-ground ETC operations and SLA adherence .....	130
6.	Status of Damages for breach of maintenance activities .....	131
6.1.	Damages for non completion of project facilities.....	131
6.2.	Damages for breach of maintenance activities.....	131
6.3.	Damages for non completion of major maintenance/ periodic overlay .....	132

7.	Change of Scope proposals .....	134
8.	Status of pending disputes .....	134
9.	Reports .....	136
9.1.	Monthly Toll Collection Report (Applicable only if project highway is tolled) ..	136
9.2.	Accident Report .....	138
9.3.	Details of complaints .....	140
9.4.	Encroachment list.....	141
9.5.	Lane Closure Report.....	141
10.	Annexures.....	142

*All figures and graphs in templates are illustrative. Please add actual details.*

## 1. Executive Summary

### 1.1. Overall road condition

Road condition	LHS	RHS
Satisfactory road condition	40 km	20 km
Poor road condition	50 km	70 km
<b>Total length of project</b>	<b>90 km</b>	<b>90 km</b>

### 1.2. Key reporting metrics

Key metrics	Value/Amount
No of pending NCRs	35
Damages amount recommended on Contractor (Rs Cr)	Rs 5.9 Cr
No of pending Change of Scope proposals	2
No of pending disputes	2
Monthly toll collection (Rs Cr) <i>(If applicable)</i>	Rs 3.8 Cr
No of accidents	12
No of encroachments	47

### 1.3. Key maintenance activities undertaken

Asset	Maintenance activities undertaken
Pavement	<ul style="list-style-type: none"> <li>Contractor has commenced the work for renewal and repair of pavement on the project highway w.e.f 14th September 2016</li> </ul>
Shoulder	
Drainage	<ul style="list-style-type: none"> <li>Cleaning of drainage in builtup areas in progress</li> </ul>
Median	
Road furniture	<ul style="list-style-type: none"> <li>Contractor has taken up repairs and maintenance of MCB and electric poles, etc on issuance of NCPs from Supervision Consultant</li> </ul>
Bridges	
Buildings	<ul style="list-style-type: none"> <li>As per provisions of CA and policy decided by MoRTH/NHAI, 2 ETC lanes at each toll plaza have been operationalised w.e.f. 25th September 2016. The connectivity of ETC lanes with Central Clearing House (CCH) has been achieved and presently ETC lanes are</li> </ul>

Asset	Maintenance activities undertaken
	operationalized in Hybrid Mode due to less number of tags purchased by highway users
Horticulture	<ul style="list-style-type: none"> <li>• Planting of new trees from Chainage 200+300 to 226+650</li> <li>• Trimming of plants which were causing obstruction to highway users</li> </ul>

#### 1.4. Pending issues

- Overlay on the entire stretch of project length of 252 km and service roads has not been taken up by Contractor yet since the date of completion of overlay is due in next 25 days
- Over all progress is very slow regarding repair of potholes and rutting on Main Carriageway which is causing inconvenience to highway users and is also a concern from road safety point of view.
- Street lighting in
  - **Anantapur bypass** completed on main carriageway and is energized but for service roads street lighting is pending on both sides
  - **Kurnool bypass** erection of poles only completed in main carriageway not yet energized till to date, but for service roads not started

#### 1.5. Recommended actions by Supervision Consultant

- In spite of the repeated requests, there is no material change in status of works pertaining to repairs/ rectifications of defects on the project highway. SC has recommended the damages of Rs 5.9 Cr on the Contractor on account of delay in repairs of defects in road and bridge works in terms of the provision of Clause 15.8.1 of the Contract Agreement. Contractor shall be liable for imposition of further damages on similar lines till the date of completion
- Contractor is requested to take at most care for completing the overlay before 31.03.2017 since the existing road condition is getting deteriorated day by day causing much inconvenience to the traffic

*All figures and graphs in templates are illustrative. Please add actual details.*

### 1.6. Strip Plan for maintenance

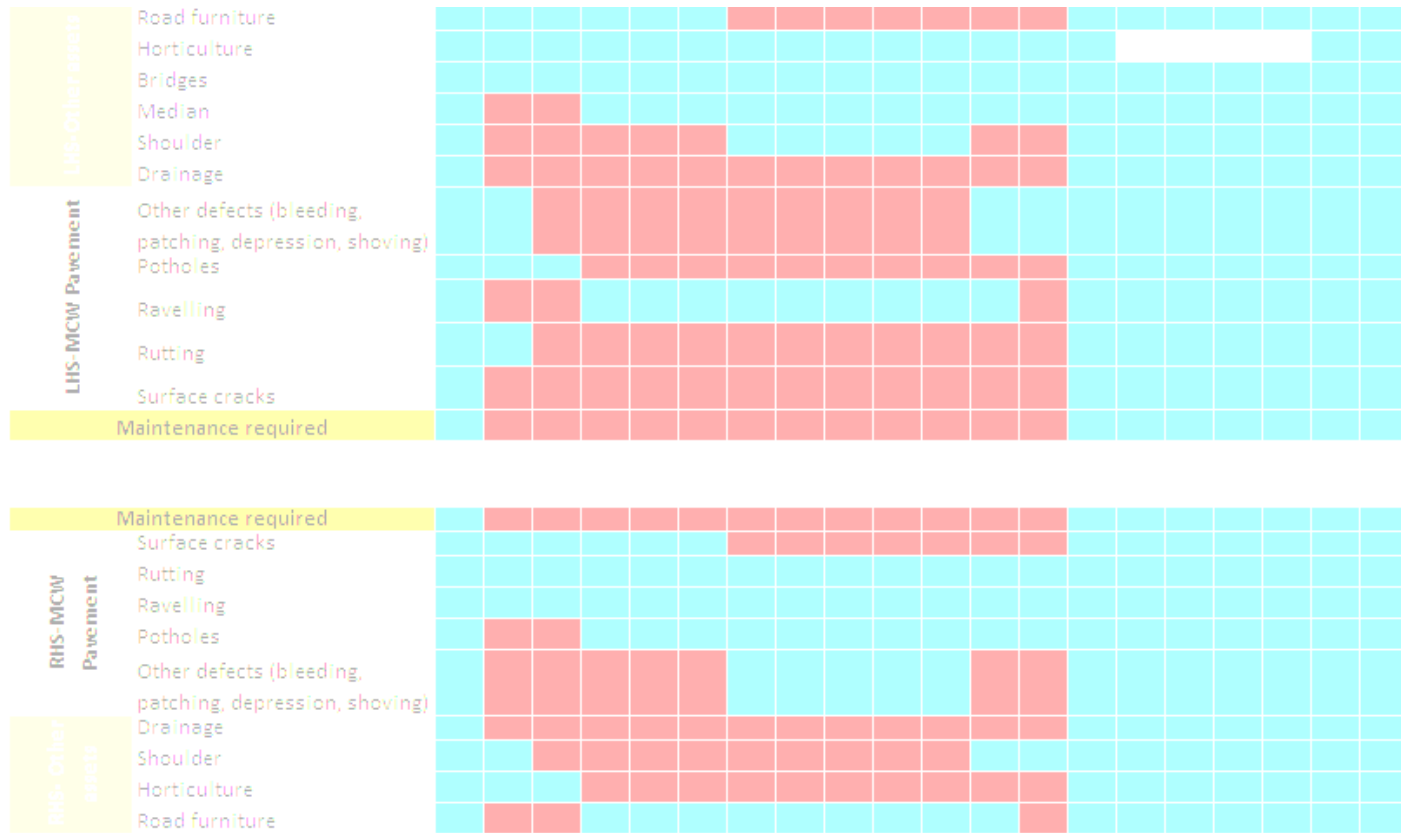

*All figures and graphs in templates are illustrative. Please add actual details.*

## Main report

### 2. Project Overview

#### 2.1. Key project details

Project Name	
NH no (New/Old)	
Mode of the Project	
No. of Lanes	
Length of the Project	
Total Project Cost	
Concessionaire/ Contractor	
Date of Award (LOA date)	
Appointed Date	
Commercial Operation Date (COD)	
Contract Period	
O&M Period	
Supervision Consultant	
SC Agreement Date	
SC Mobilization Date	
SC Scheduled Completion Date	
SC EOT (Extension Of Time)	

*All figures and graphs in templates are illustrative. Please add actual details.*

## 2.2. Location Map

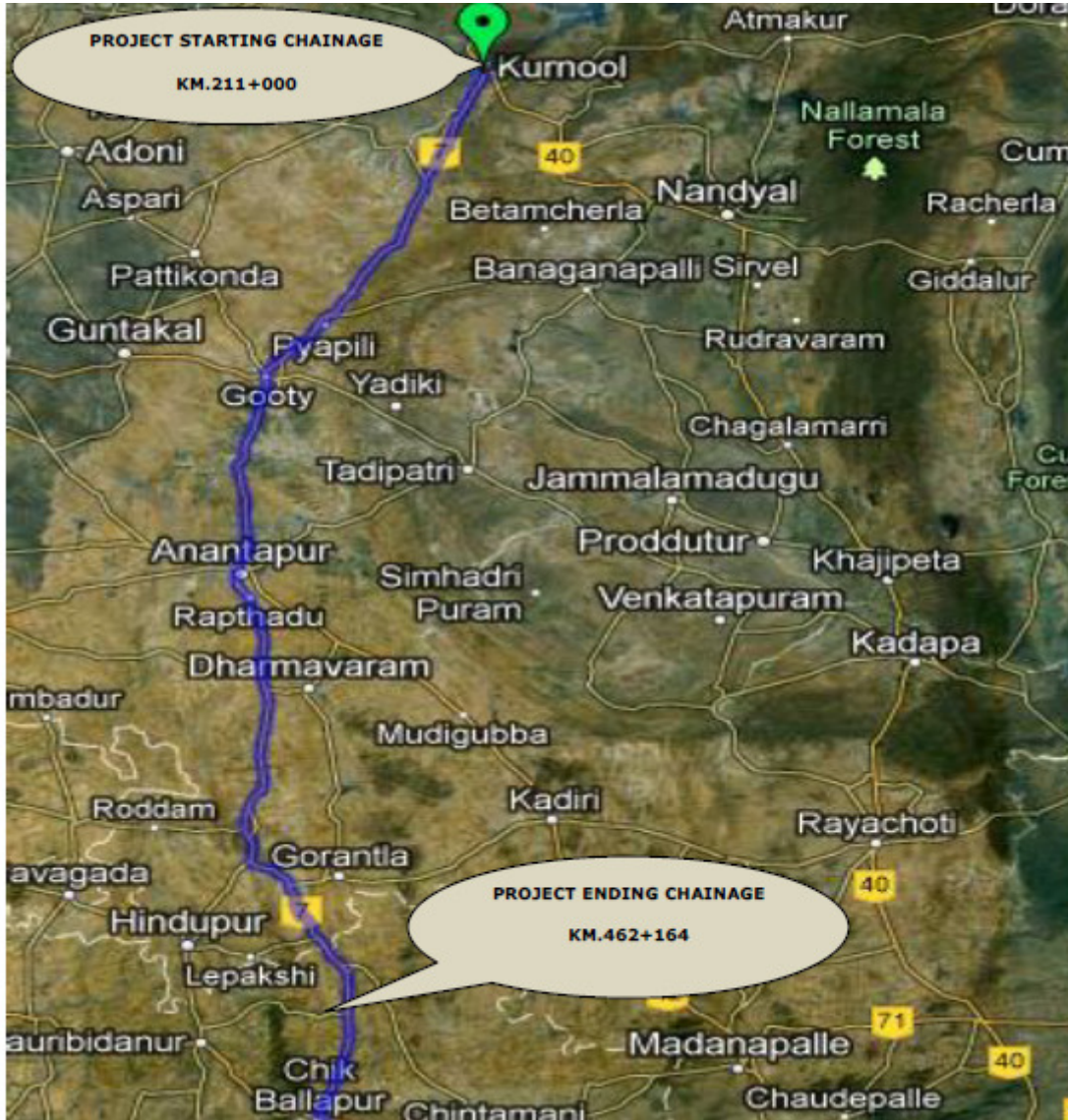

*All figures and graphs in templates are illustrative. Please add actual details.*

### 2.3. Key plan

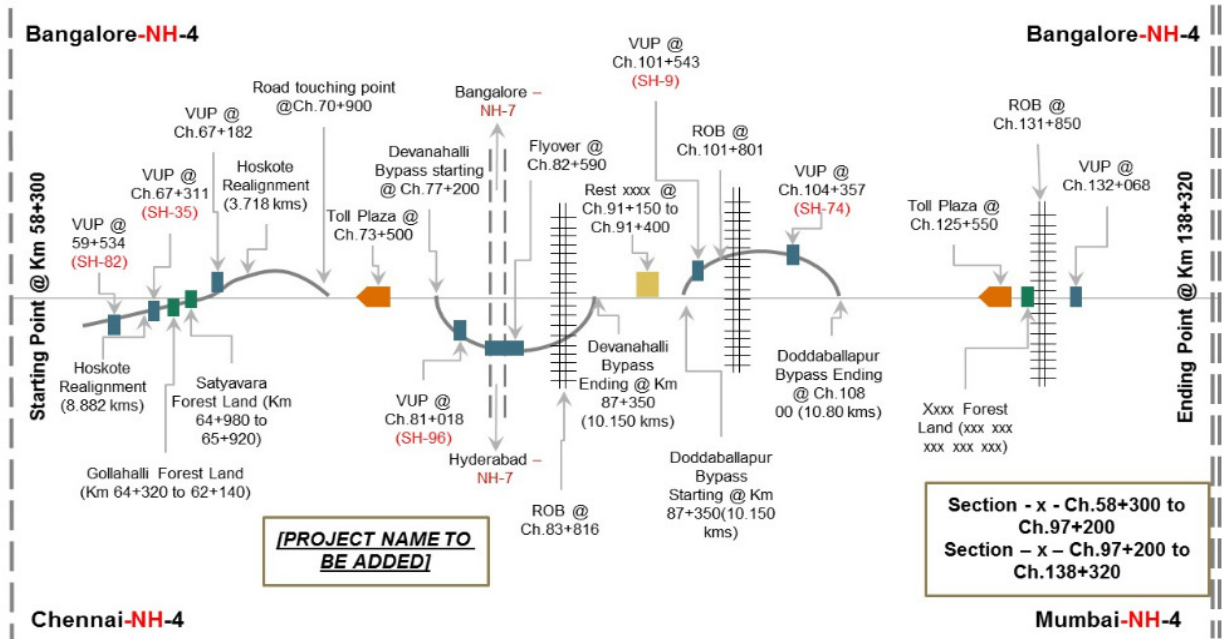

### 2.4. RoW availability

Width of RoW available on both sides of the highway

LHS- Width of RoW available	Chainage									
	>20 m									
20 m										
18 m										
16 m						16	16	16	16	16
14 m										
12 m										
10 m										
8 m			8.2	8.2	8.2	8.2	8.2			
6 m										
4 m									4.7	4.7
2 m	1.8	1.8								
RHS- Width of RoW available	2 m									
	4 m									
	6 m							6.2	6.2	6.2
	8 m									
	10 m	10	10							
	12 m									
	14 m									
	16 m									
	18 m			17.5	17.5	17.5	17.5	17.5	17.5	17.5
	20 m									
>20 m									25	

*All figures and graphs in templates are illustrative. Please add actual details.*

## 2.5. Summary of project features

SNo	Particulars	Value
1	No of flyovers	2
2	Service Road	45
3	ROBs	5
4	ROB location (chainage)	261.975, 299.606, 350.547, 396.135 & 420.302
5	RUBs	0
6	RUB location (chainage)	NA
7	No of Bypass	7
8	Length of Bypass	43
9	No of Major Bridges	7
10	No of Minor Bridges	67
11	No of Culvert	640
12	No of VUP	16
13	No of PUP/ Cattle Underpass	12
14	No of Major Intersection/ Junction	22
15	No of Toll Plaza	3
16	Location of Toll Plaza (chainage)	
17	No of Truck Laybye	30
18	No of Bus Bays	122
19	No of Wayside Amenities	0
20	Location of Wayside Amenities (chainage)	NA

*All figures and graphs in templates are illustrative. Please add actual details.*

### 3. Critical Issues and Action taken

#### 3.1. Issue and action log

SNo	Issue Description	Ongoing/New Issue	Concerned Authority	Chainage(s) affected due to the issue	Length affected (km)	Action(s) taken till now	Action(s) suggested by SC	Expected Date resolving issue
1	Drying up of plants on median	Ongoing	Contractor	325+200 to 327+800	2.6	Irregular watering	Replacement of plants and daily watering	NA
2	Large potholes	New	Contractor	387+300 LHS	0.1	None	Filling of potholes	<DD/MM>

*All figures and graphs in templates are illustrative. Please add actual details.*

#### 3.2. Summary of items (Cumulative Observations/ Deficiencies)

SNo	Description	Unit	Total	Work done upto previous month	Work done during reporting month	Balance	Remarks
1	<b>Carriageway and paved shoulders</b>						
(a)	Pot Holes	Sqm	42	-	-	42	
(b)	Roughness value exceeding 2,500mm	mm					
(c)	Cracking in more than 5% of road surface	Sqm	7179	-	-	7179	

SNo	Description	Unit	Total	Work done upto previous month	Work done during reporting month	Balance	Remarks
(d)	Rutting exceeding 10mm in more than 2% of road surface	Sqm	5	-	-	5	
(e)	Bleeding/Skidding	Sqm					
(f)	Ravelling	Sqm					
(g)	Damage to pavement edges exceeding 10cm	m					
<b>2</b>	<b>Hard/Earth Shoulders</b>						
(a)	Rain cuts/ gullies in slope	Cum	650	25	-	625	
(b)	Edge drop at shoulders exceeding 40 mm	m					
<b>3</b>	<b>Drains and culverts</b>						
(a)	Cleaning of Culvert	Nos	1	-	-	1	
(b)	Damage to or silting of culverts						
(c)	Silting of drains in urban/ semi urban areas						
<b>4</b>	<b>Road furniture</b>						
(a)	Sign Boards	Nos	456	-	-	456	
(b)	Kilometer Stones						
(c)	Metal Beam Crash Barrier						
(d)	Bus Shelters	Nos	72	4	-	68	
(e)	Junction signs	Nos	26	8	-	18	

SNo	Description	Unit	Total	Work done upto previous month	Work done during reporting month	Balance	Remarks
(f)	Median Grills	Rmt	894	-	-	894	
(g)	Studs	Nos	5328	-	-	5328	
(h)	Delineators	Nos	8236	-	-	8236	
(i)	Road Marking	Sqm	1899	-	-	1899	
(j)	Kerb Painting	Sqm	4575	-	-	4575	
(k)	Guard Posts	Nos	3657	-	-	3657	
<b>5</b>	<b>Street lighting and telecom (ATMS)</b>						
(a)	Street lights	Nos					
(b)	Telecom	Nos					
<b>6</b>	<b>Trees and plantation</b>						
(a)	Removal of vegetation affecting sight line and road structures	Ha	77.42	-	3.57	73.85	
(b)	Replacement of trees and bushes	Nos	15072	-	-	15072	
<b>7</b>	<b>Buildings and bridges</b>						
(a)	Rest areas						
(b)	Toll plazas						
(c)	Bridges						

### 3.3. Obligations as per contract

Please write a summary of contractual obligations of Contractor and non-compliances of critical obligations highlighting reasons for delay and stating pending actions

- Critical obligations of Contractor as per contract
  
- Non compliances of critical contractual obligations

### 3.4. Major maintenance and Inspection schedule

Item	Responsibility	Last completed on	Due date
Major maintenance	Contractor	[DD/MM/YY]	[DD/MM/YY]
Periodic overlay	Contractor	[DD/MM/YY]	[DD/MM/YY]
Pavement inspection using NSV	Supervision Consultant	[DD/MM/YY]	[DD/MM/YY]
Roughness using Laser Profilometer	Supervision Consultant	[DD/MM/YY]	[DD/MM/YY]
Pavement strength using FWD	Supervision Consultant	[DD/MM/YY]	[DD/MM/YY]
Culvert inspection using GPR	Supervision Consultant	[DD/MM/YY]	[DD/MM/YY]
Bridge inspection using MBIU	Supervision Consultant	[DD/MM/YY]	[DD/MM/YY]
Road sign inspection using Reflectometer	Supervision Consultant	[DD/MM/YY]	[DD/MM/YY]
Other			



*All figures and graphs in templates are illustrative. Please add actual details.*

## 4. Inspection Report

### 4.1. Summary of NCR issued

SNo	Highway asset	Total NCR issued till previous month (A)	NCR issued in reporting month (B)	NCR closed in reporting month (C)	Balance NCR (A+B-C)
1	Pavement	48	12	25	35
2	Shoulder	7	0	3	4
3	Drainage				
4	Median				
5	Road furniture				
6	Bridges				
7	Buildings				
8	Horticulture				
9	<i>[Other assets]</i>				
	<b>Total</b>				

## 4.2. Equipment based inspection report

Starting Chainage	Ending Chainage	Lane number	Pavement Surface Defects							Roughness	Pavement Strength		
			Cracks (cm)	Potholes (cm)	Raveling (cm)	Bleeding (cm)	Rutting depth (mm)	Texture depth (mm)	Skid Resistance (mm)		IRI (International Roughness Index)	Elastic Modulus Bituminous E1	Elastic Modulus Granular E2
0.000	0.500	L1	2X10	20X35	2.5X1.2	4X12	25	1.4		4.23	7110	34	14
0.500	1.000	L1	3X5	10X15	1.5X0.8	3X10	24	1.8		2.68	7430	36	15
1.000	1.500	L1											

Report of equipment based inspection needs be provided as an Annexure to monthly report as per the defined frequency. Following documents/media to be submitted for equipment based inspection.

- Video footage of all cameras installed on Network Survey Vehicle- ROW cameras and pavement camera
- Network Survey Vehicle report capturing dimensions of following key metrics of pavement
  - Cracks
  - Potholes
  - Raveling
  - Bleeding
  - Rutting

- 
- Texture depth
  - Skid resistance
  - Roughness (IRI)
  - Falling Weight Deflectometer (FWD) report capturing following key metrics of pavement strength
    - Deflection Bowl (Transient Deflections at seven different points)
    - Corrected Elastic Modulus Bituminous E1
    - Corrected Elastic Modulus Granular E2
    - Corrected Elastic Modulus Subgrade E3
    - Subgrade CBR
    - Bituminous layer coefficient A1
    - Base layer coefficient A2
    - Granular base layer coefficient A3
    - Modified structural number
  - Mobile Bridge Inspection Report (MBIU) capturing following key metrics of bridges
    - Condition Approach
    - Condition Signs
    - Condition Debris
    - Condition Joint
    - Condition Deck
    - Condition Rails
    - Condition Protect
    - Condition Stream
    - Condition Superstructure
    - Condition Piers
    - Condition Abutment

- Retroreflectometer report capturing following key metrics of road furniture
  - Coefficient of retroreflected luminance  $R_A$  (nighttime retroreflection) of road traffic signs
- ATCC report capturing ADT, AADT, hourly and weekly variations and recommendation on capacity augmentation

*All figures and graphs in templates are illustrative. Please add actual details.*

## 5. Monitoring of ETC lanes

### 5.1. Monthly ETC Report

TYPE OF VEHICLE			For Corresponding month of previous year		For Previous Month		For Current Month		
			No of vehicles	Fee Collected	No of vehicles	Fee Collected	Fee per vehicle	No of vehicles	Fee Collected
A	Car	Total	3845	384500	4659	465,900.00	100	4289	428,900.00
B	LCV	Total	1521	243360	1312	209,920.00	160	1399	223,840.00
C	Bus	Total	2404	793386	2284	765,207.00	201	2349	786,915.00
D	Truck	Total	1603	528924	1523	510,138.00	134	1566	524,610.00
E	3 Axle	Total	18990	6836400	16310	5,953,150.00	365	15127	5,521,355.00
F	MAV	Total	16119	8381880	21111	11,188,830.00	530	18790	9,958,700.00
G	Over Size	Total	1	630	27	17,280.00	640	36	23,040.00
Total for the Month			49844	18,050,618	52963	19,898,834		49016	18,265,661

### 5.2. On-ground infrastructure report

Total number of plaza lanes =

Total number of dedicated ETC lanes =

Total number of hybrid lanes =

SNo	Description	Total units	Units working	Units damaged/missing	Equipment owner/provider	Equipment as per specifications (Y/N)	Remarks
<b>1</b>	<b>Hardware</b>						
(a)	Over-head transceiver	4	3	1	ABC Co.	Y	
(b)	Hand-held reader						
(c)	Lane controller						
(d)	AVC						
(h)	Camera						
(l)	Weigh-in-motion						
(m)	Static weigh bridge						
(n)	Any other items						
<b>2</b>	<b>Softwares</b>						
(a)	Software - Lane/ Plaza level						
(c)	TMS						

SNo	Description	Total units	Units working	Units damaged/missing	Equipment owner/provider	Equipment as per specifications (Y/N)	Remarks
(d)	Any other items						

### 5.3. On-ground ETC operations and SLA adherence

Lane	Average queue length during peak time	Average queue length during non peak time	Average Transaction time (cash)	Average transaction time (RFID)	Average transaction time (cards)	Average transaction time (wallet)	Average transaction time (others)
Lane 1	10 vehicles	5 vehicles	15 seconds	10 seconds	20 seconds	25 seconds	UPI - 20 seconds
Lane 2							
Lane 3							

- Average system uptime = 80%
- Transactions uploaded (as per SLA) = 80%
- Blacklists uploaded (as per SLA) = 50%
- Blacklists downloaded (as per SLA) = 85%

## 6. Status of Damages for breach of maintenance activities

### 6.1. Damages for non completion of project facilities

SNo	Period	Amount of damages (Rs)
1	Upto June 2016	15,00,35,000
2	Jul 2016	2,00,88,000
3	Aug 2016	2,00,88,000
4	Sep 2016	1,94,40,000
	<b>Total</b>	<b>20,96,51,000</b>

#### Supporting Calculations for damages for Sep 2016

- No of days in Sep = 30
- Performance security is Rs 64,80,00,000
- As per CA Clause 12.3.2 damages payable is 0.1% of performance security per day = Rs 6,48,000
- Total damages payable = 30 X 6,48,000 = Rs 1,94,40,000

### 6.2. Damages for breach of maintenance activities

SNo	Period	Amount of damages (Rs)
1	Upto June 2016	1,00,35,000
2	Jul 2016	6,63,196
3	Aug 2016	6,63,196

SNo	Period	Amount of damages (Rs)
4	Sep 2016	52,22,444
	<b>Total</b>	<b>1,65,83,836</b>

#### Supporting Calculations for damages for reporting month

S No	Nature of defect	Unit	Total Quantity	Rate	Cost of repair as estimated	Damages as per CA	Damages at higher side	Date of inspection	No of days as per CA	Damages from	No of days damages	Damages amount

#### 6.3. Damages for non completion of major maintenance/ periodic overlay

SNo	Period	Amount of damages (Rs)
1	June 2016	6,48,000
2	Jul 2016	2,00,88,000
3	Aug 2016	2,00,88,000
4	Sep 2016	1,94,40,000

SNo	Period	Amount of damages (Rs)
	<b>Total</b>	<b>6,02,64,000</b>

### Supporting Calculations for damages for Sep 2016

- No of days in Sep = 30
- Performance security is Rs 64,80,00,000
- As per CA Clause 12.3.2 damages payable is 0.1% of performance security per day = Rs 6,48,000
- Total damages payable =  $30 \times 6,48,000 = \text{Rs } 1,94,40,000$

*All figures and graphs in templates are illustrative. Please add actual details.*

## 7. Change of Scope proposals

SNo	Proposal Details	Date of first submission to SC	Current status	COS Amount	Expected/ Actual date of approval
1	Construction of [Flyover Name] at [Chainage]	[DD/MM/YYYY]	Approved in principle by Authority. Detailed quantities in proper order yet to be submitted	[+/- Amount]	[DD/MM/YYYY]
2	Nallah diversion through box culvert at [Chainage]	[DD/MM/YYYY]	Clarifications to be submitted by Contractor, expected date [DD/MM/YYYY]	[+/- Amount]	[DD/MM/YYYY]

## 8. Status of pending disputes

SNo	Dispute Details	Date of first submission to SC	Suggested resolution by SC	Dispute Amount (if applicable)	Current stage
1	Increased tollable length to be applicable in toll fee calculations	[DD/MM/YYYY]	No merit in increasing tollable length hence no action required by NHAI	NA	SAROD

---

2	Filling stations energized without obtaining NOC from ministry	[DD/MM/YYYY]	NHAI to consider the Contractor's request for intervention and assistance	[+/- Amount]	B/w Contractor and NHAI
---	--	--------------	---	--------------	-------------------------

*All figures and graphs in templates are illustrative. Please add actual details.*

## 9. Reports

### 9.1. Monthly Toll Collection Report (Applicable only if project highway is tolled)

TYPE OF VEHICLE			For Corresponding month of previous year		For Previous Month		For Current Month		
			No of vehicles	Fee Collected	No of vehicles	Fee Collected	Fee per vehicle	No of vehicles	Fee Collected
A	Car	Single	3845	384500	4659	465,900.00	100	4289	428,900.00
		Return	1506	218370	1972	295,800.00	150	1758	263,700.00
		Local	769	38450	979	48,950.00	50	1029	51,450.00
B	LCV	Single	1521	243360	1312	209,920.00	160	1399	223,840.00
		Return	134	31490	162	38,880.00	240	132	31,680.00
		Local	1683	134640	1838	147,040.00	80	1461	116,880.00
C	Bus	Single	2404	793386	2284	765,207.00	201	2349	786,915.00
		Return	359	177903	173	87,567.00	303	203	102,717.00
		Local	277	45738	205	34,782.00	102	318	54,060.00
D	Truck	Single	1603	528924	1523	510,138.00	134	1566	524,610.00
		Return	240	118602	116	58,378.00	202	136	68,478.00

TYPE OF VEHICLE			For Corresponding month of previous year		For Previous Month		For Current Month		
			No of vehicles	Fee Collected	No of vehicles	Fee Collected	Fee per vehicle	No of vehicles	Fee Collected
		Local	185	30492	136	23,188.00	68	212	36,040.00
E	3 Axle	Single	18990	6836400	16310	5,953,150.00	365	15127	5,521,355.00
		Return	131	70740	34	18,700.00	550	37	20,350.00
		Local	69	12420	84	15,540.00	185	131	24,235.00
F	MAV	Single	16119	8381880	21111	11,188,830.00	530	18790	9,958,700.00
		Return	2	1550	20	15,800.00	790	35	27,650.00
		Local	6	1560	18	4,770.00	265	8	2,120.00
G	Over Size	Single	1	630	27	17,280.00	640	36	23,040.00
		Return		0	0	-	965		-
		Local		0	0	-	320		-
<b>Total for the Month</b>			<b>49844</b>	<b>18,050,618</b>	<b>52963</b>	<b>19,898,834</b>		<b>49016</b>	<b>18,265,661</b>

*All figures and graphs in templates are illustrative. Please add actual details.*

## 9.2. Accident Report

S No	Date	Chainage no	Time of accident	Sex (M/F)	A	B	C	D	E	F	G	H	I	J	K	No of affected persons			Help provided by
					Accident location	Nature of accident	Classification of accident	Causes	Load conditions of vehicle	Road condition	Intersection type of control	Weather condition	Age of victim	Type of victim	Type of vehicle	Fatal	Major	Minor	
1	1/1/17	382/050 RHS	05:25 pm	M	2	2	3	4	1	1	.	1	3	1	3	.	1	1	Ambu

## Mapping of report fields to responses

A	1. Urban 2. Rural
B	1. Overturned 2. Head On Collision 3. Hit from Back 4. Hit to Fix Object 5. Right turn Collision 6. Left turn Collision 7. Veered Out off The Road 8. Hit Pedestrian 9. Unknown/Hit & Ran Away
C	1. Fatal 2. Major injury 3. Minor injury
D	1. Drunken 2. Over Speeding 3. Vehicle out of Control 4. Driven on wrong side 5. Mechanical Problem 6. Drowsiness/Not Applicable 7. Fault of Driver
E	1. Normally Loaded 2. Overloaded/Handing 3. Empty 4. Unknown
F	1. Straight road 2. Slight Curve 3. Sharp Curve 4. Hump 5. Dip
G	1. T-Junction 2. Y-Junction 3. Four arm Junction 4. Staggered Junction 5. Junction with more than 6. Round about Junction
H	1. Fine/Clear 2. Mist/Fog 3. Cloudy 4. Light Rain 5. Heavy Rain 6. Strong Wind 7. Dust Storm 8. Cold 9. Hot
I	1. 0-18 Years 2. 18-25 Years 3. 25-40 Years 4. 40-60 Years 5. 60-80 Years
J	1. Driver 2. Passenger 3. Pedestrian 4. Cyclist 5. Others
K	1. Two Wheeler 2. Auto Rickshaw 3. Car/Jeep 4. Bus 5. Light Truck 6. Heavy Truck 7. Tractor 8. Bicycle 9. Cycle Rickshaw 10. Hand Drawn Cart 11. Animal Drawn Cart

*All figures and graphs in templates are illustrative. Please add actual details.*

### 9.3. Details of complaints

SNo	Toll plaza	Complaint No	Date	Name of the person	Contact details of person	Details of complaint	Compliance by the Contractor
1		81	8/9/2016	Mr. Shailendra Gurjar, LIG-44, RSS mohalla, Shivaji Nagar, Bhopal (M.P.)		Mr. Shailendra Complaints regarding Pot holes on the Highway may cause accidents.	Pot holes are repaired
2		82	10/9/2016	Dr. Anil Diwakar, HIG Swarganga Complex Bus Stand Seoni (M.P.)		Dr. Diwakar complaints that presence of Animals and also Pot holes on road are obstructing the driving which may cause accidents.	Animals are continuously driven out from the Road by the Highway Patrolling team and Pot holes are repaired.
3		83	11/9/2016	Maj. Sidharth, 238 Fd wksp C/o- 56 APO		Maj. Sidharth while travelling in personal car wants Exemption from Toll Fee on production of I.D. Card	The Exemption under Indian Toll (Army and Air force) Act 1901, to army personnel travelling in private vehicle may be given if on Govt. duty with requisite pass as specified in the Indian Toll (Army and Air Force Rules, 1942)

*All figures and graphs in templates are illustrative. Please add actual details.*

#### 9.4. Encroachment list

SNo	Stretch (km)	Chainage	Side (LHS/RHS)	District/ Tehsil	Village	Encroachment type (Temporary/ Permanent)	Category (Tea stall, Temple, etc)	Establishment (New/ existing)	Distance from road edge (m)	Encroachment width and length	Name of Encroacher
1	212+500		LHS	Kurnool	Kurnool	Temporary	Tea stall	New	7	5mX3.5m	Vijay Kumar Reddy
2	213+200		RHS	Kurnool	Dinnedevera Padu	Permanent	Godown	Existing	5	10.5m X 4m	Buddana

#### 9.5. Lane Closure Report

S.No	Date	Chainage (Km)		Side	Time of Closure	Reasons for Lane Closure & Approval Details	Remarks
		From	To				
1	9/9/2016	215+300	215+350	RHS	1pm-4pm	Patch work	

## 10. Annexures

### Annexure 1: Detailed visual inspection report of project highway

**Assets to be covered-** Pavement, Shoulder, Drainage, Median, Bridges, Road furniture, Buildings, Horticulture, Service Road

Nature of defect or deficiency	Defect found (Yes/No)	If defect found, Chainage & side	Compliance of previous defect (Yes/No/NA)	SC Remarks
<b>ROADS</b>				
<b>(a)</b>	<b>Carriageway and paved shoulders</b>			
<b>(i)</b>	Breach or blockade			
<b>(ii)</b>	Roughness value exceeding 2,500 mm in a stretch of 1 km (as measured by a standardised roughometer/bump integrator)			
<b>(iii)</b>	Pot holes			
<b>(iv)</b>	Cracking in more than 5% of road surface in a stretch of 1 km			
<b>(v)</b>	Rutting exceeding 10 mm in more than 2% of road surface in a stretch of 1 km			

	Nature of defect or deficiency	Defect found (Yes/No)	If defect found, Chainage & side	Compliance of previous defect (Yes/No/NA)	SC Remarks
	(measured with 3 m straight edge)				
(vi)	Bleeding/skidding				
(vii)	Ravelling/Stripping of bitumen surface exceeding 10 sq m				
(viii)	Damage to pavement edges exceeding 10 cm				
(ix)	Removal of debris				
<b>(b)</b>	<b>Hard/earth shoulders, side slopes, drains and culverts</b>				
(i)	Variation by more than 2% in the prescribed slope of camber/cross fall				
(ii)	Edge drop at shoulders exceeding 40 mm				
(iii)	Variation by more than 15% in the prescribed side (embankment) slopes				

	Nature of defect or deficiency	Defect found (Yes/No)	If defect found, Chainage & side	Compliance of previous defect (Yes/No/NA)	SC Remarks
(iv)	Rain cuts/gullies in slope				
(v)	Damage to or silting of culverts and side drains during and immediately preceding the rainy season				
(vi)	Desilting of drains in urban/semi-urban areas				
(c)	<b>Road side furniture including road signs and pavement marking</b>				
(i)	Damage to shape or position; poor visibility or loss of retro-reflectivity				
(d)	<b>Street lighting and telecom (ATMS)</b>				
(i)	Any major failure of the system				
(ii)	Faults and minor failures				
(e)	<b>Trees and plantation</b>				

Nature of defect or deficiency		Defect found (Yes/No)	If defect found, Chainage & side	Compliance previous of defect (Yes/No/NA)	SC Remarks
(i)	Obstruction in a minimum head-room of 5 m above carriageway or obstruction in visibility of road signs				
(ii)	Deterioration in health of trees and bushes				
(iii)	Replacement of trees and bushes				
(iv)	Removal of vegetation affecting sight line and road structures				
<b>(f)</b>	<b>Rest areas</b>				
(i)	Cleaning of toilets				
(ii)	Defects in electrical, water and sanitary installations				
<b>(g)</b>	<b>Toll plaza[s]</b>				
(i)	Failure of toll collection equipment including ETC or lighting				

	Nature of defect or deficiency	Defect found (Yes/No)	If defect found, Chainage & side	Compliance of previous defect (Yes/No/NA)	SC Remarks
(ii)	Damage to toll plaza				
(h)	<b>Other Project Facilities and Approach roads</b>				
(i)	Damage or deterioration in Approach Roads, -[pedestrian facilities, truck lay-bys, bus-bays, bus- shelters, cattle crossings, Traffic Aid Posts, Medical Aid Posts and other works]				
<b>BRIDGES</b>					
(a)	<b>Superstructure of bridges</b>				
(i)	Cracks				
(ii)	Spalling/scaling				
(b)	<b>Foundations of bridges</b>				
(i)	Scouring and/or cavitation				

Nature of defect or deficiency	Defect found (Yes/No)	If defect found, Chainage & side	Compliance of previous defect (Yes/No/NA)	SC Remarks
(c)	<b>Piers, abutments, return walls and wing walls of bridges</b>			
(i)	Cracks and damages including settlement and tilting			
(d)	<b>Bearings (metallic) of bridges</b>			
(i)	Deformation			
(e)	<b>Joints in bridges</b>			
(i)	Loosening and malfunctioning of joints			
(f)	<b>Other items relating to bridges</b>			
(i)	Deforming of pads in elastomeric bearings			
(ii)	Gathering of dirt in bearings and joints; or clogging of spouts, weep holes and vent-holes			

	Nature of defect or deficiency	Defect found (Yes/No)	If defect found, Chainage & side	Compliance of previous defect (Yes/No/NA)	SC Remarks
(iii)	Damage or deterioration in parapets and handrails				
(iv)	Rain-cuts or erosion of banks of the side slopes of approaches				
(v)	Damage to wearing coat				
(vi)	Damage or deterioration in approach slabs, pitching, apron, toes, floor or guide bunds				
(vii)	Growth of vegetation affecting the structure or obstructing the waterway				

## Annexure 2 onwards:

SC should include comments, status update, data points and reports in following annexures which have not been included elsewhere in the main report. Such reports may include but not limited to:

- Minutes of review meeting
- Correspondence details

- Weather report
- Organizational chart of Contractor and IE
- Project photographs

**Annexure IV- Month of survey for equipment based road condition assessment**

Equipment based road inspection shall be done by the Consultant twice a year as per the month of the year defined in the following table.

However, since the first survey shall be conducted within 30 days of appointment of the Supervision Consultant, the following modification to the schedule shall be adopted. For example, if majority of highway length (>50%) passes through a state, where defined survey months are May and November, if appointed date is on 1<sup>st</sup> March, then the first equipment based survey shall be conducted in the month of March within 30 days of appointment and this shall be considered as the equipment based survey to be conducted in the month of May. The 2<sup>nd</sup> equipment based survey shall be conducted in the month of November, the 3<sup>rd</sup> survey shall be conducted in the month of May and so on. As regards FWD, the first test/survey shall be conducted in the month of March within 30 days of appointment. The 2<sup>nd</sup> test/survey shall be conducted in March of next year and so on.

Region	State	Survey before rains	Survey after rains
East	Bihar	May	Nov
East	Chhattisgarh	May	Nov
East	Jharkhand	May	Nov
East	Orissa	May	Nov
East	West Bengal	May	Nov
Central	Madhya Pradesh	May	Nov
NE	Arunachal Pradesh	Mar	Oct
NE	Assam	Mar	Oct
NE	Manipur	Mar	Oct
NE	Meghalaya	Mar	Oct

<b>Region</b>	<b>State</b>	<b>Survey before rains</b>	<b>Survey after rains</b>
NE	Mizoram	Mar	Oct
NE	Nagaland	Mar	Oct
NE	Sikkim	Mar	Oct
NE	Tripura	Mar	Oct
North	Chandigarh	May	Nov
North	Delhi	May	Nov
North	Haryana	May	Nov
North	Himachal	May	Nov
North	Jammu And Kashmir	May	Nov
North	Punjab	May	Nov
North	Uttar Pradesh	May	Nov
North	Uttaranchal	May	Nov
South	Andaman And Nicobar Islands	Apr	Nov
South	Andhra Pradesh	Apr	Nov
South	Karnataka	Apr	Nov
South	Kerala	Apr	Nov
South	Pondicherry	Jun	Jan
South	Tamil Nadu	Jun	Jan

<b>Region</b>	<b>State</b>	<b>Survey before rains</b>	<b>Survey after rains</b>
West	Dadar Nagar Haveli	Apr	Oct
West	Daman And Diu	Apr	Oct
West	Goa	May	Nov
West	Gujarat	Apr	Oct
West	Maharashtra	May	Nov
West	Rajasthan	Apr	Oct

**Annexure V-OUTPUT FORMAT FROM NETWORK SURVEY VEHICLE AND FWD TESTING**



[NAME & LOGO OF IMPLEMENTING AGENCY]

*[PROJECT NAME]*

**Independent Engineer**

*[NAME OF CONSULTING FIRM]*

OUTPUT FROM NETWORK SURVEY VEHICLE AND FWD TESTING

## Table of contents

Contents	Page Nos.
<b>SECTION 1 ROAD INVENTORY DATA</b>	<b>143</b>
1.1. Location Reference Post (LRP) Master	143
1.2. Carriageway Type	144
1.3. Road Type	145
1.4. Pavement Type	146
1.5. Pavement Width	147
1.6. Shoulder Type	148
1.7. Shoulder Width	149
1.8. Topography	151
1.9. Cross Section	151
1.10. Drain Type	153
1.11. Median Opening	154
1.12. Right Of Way	155
1.13. Pavement composition	156
1.14. Carriageway Furniture	159
1.15. Wayside Amenities	160
1.16. Land Use	161
 <b>SECTION 2 ROAD CONDITION DATA</b>	 <b>163</b>
2.1. Visual condition	163
2.2. Roughness	167
2.3. Rutting	169
2.4. Texture Depth	170
2.5. Skid Resistance	171
2.6. Falling Weight Deflectometer (FWD)	173
2.7. Falling Weight Deflectometer (FWD) Rigid	177

**Annexure V: OUTPUT FORMAT FROM NETWORK SURVEY VEHICLE AND FWD TESTING (SECTION 1: TESTING WITHIN 1 MONTH OF APPOINTMENT, SECTION 2: FWD ATTRIBUTES - ANNUALLY, BALANCE PARAMETERS -BIANNUALLY)**

In addition to the reports being submitted on equipment based inspection as specified in Section 4.2 of the Monthly Progress Report in the O&M phase, the Independent Engineer (IE) shall submit electronically in excel (.xls) format certain key parameters to the Project Director in the following format.

Worksheets under Section 1 ('Road inventory data') shall be updated from surveys conducted only once within 30 days of appointed date of the Independent Engineer. Worksheets under Section 2 ('Road condition data') shall be updated from surveys carried out annually for FWD attributes and biannually for the remaining attributes.

The fields to be updated in each of the worksheets are described below. Each description is followed by an example of data for a sample project.

**SECTION 1 - ROAD INVENTORY DATA**

Road inventory data consists of parameters which provide basic information about roads such as pavement type, number of lanes, topography, etc. These parameters are largely static in nature, and therefore a survey to update this dataset shall be conducted only once within 30 days of appointed date of the Independent Engineer. The road inventory data shall be used to update specific worksheets listed below.

**1.1 Location Reference Post (LRP) Master**

The following table lists the fields which need to be populated for the 'LRP Master' attribute. The descriptions of the fields are given below.

Field	Description	Example
NHNumber	New National Highway number	NH0065
LRPName	Name of location reference post (LRP)	Km stone 17
Chainage	Chainage of the survey point (in km)	17
Direction	Direction of survey <ul style="list-style-type: none"> <li>• Increasing (chainage)</li> <li>• Decreasing (chainage)</li> </ul>	Increasing
Latitude	Latitude of survey point	9.98897
Longitude	Longitude of survey point	78.02671

Field	Description	Example
Survey Date	Date of survey in the format <DD-MM-YY>	06-05-17
Old NH Number	Old National Highway number	NH0065
Section Code	Code indicating starting and ending locations of section	HYD-VIJ (Hyderabad-Vijayawada)

A sample output is shown below for reference

NH Number	LRP Name	Chainage	Direction	Latitude	Longitude	Altitude	Survey Date	Old NH Number	Section Code
NH0xxx	Road Start	1.230	Increasing	9.98897	78.02671	63.07767	23-12-15	NH0yyy	ABC-DEF
NH0xxx	Km Stone 8	8.000	Increasing	9.98444	78.02934	68.60126	23-12-15	NH0yyy	ABC-DEF
NH0xxx	Km Stone 8	8.030	Increasing	9.98341	78.03004	68.15520	23-12-15	NH0yyy	ABC-DEF
NH0xxx	Km Stone	9.008	Increasing	9.98107	78.03078	65.17153	23-12-15	NH0yyy	ABC-DEF
NH0xxx	Km Stone	12.012	Increasing	9.96328	78.04160	56.03436	23-12-15	NH0yyy	ABC-DEF
NH0xxx	Km Stone 17	17.085	Increasing	9.95385	78.05255	56.24748	23-12-15	NH0yyy	ABC-DEF

## 1.2 Carriageway Type

The following table lists the fields which need to be populated for the 'Carriageway Type' attribute. The descriptions of the fields are given below.

Field	Description	Example
NH Number	New National Highway number	NH0065
Section Code	Code indicating starting and ending locations of section	HYD-VIJ (Hyderabad-Vijayawada)
Start Chainage	Chainage of the start point (in km)	0.500
End Chainage	Chainage of the end point (in km)	1.500
Carriageway Type	Type of carriageway, classified into one of the below categories: <ul style="list-style-type: none"> <li>Divided</li> <li>Undivided</li> </ul>	Divided
Survey Date	Date of survey in the format <DD-MM-YY>	06-05-17

Field	Description	Example
Latitude	Latitude of survey point	9.98897
Longitude	Longitude of survey point	78.02671

A sample output is shown below for reference

NHNumber	Section	Start Chainage	End Chainage	Carriageway Type	Date of Survey	Latitude	Longitude
NH00xx	ABC-DEF	0.000	0.794	Undivided	06-05-17	9.98897	78.02671
NH00xx	ABC-DEF	0.794	1.000	Undivided	06-05-17	9.98444	78.02934
NH00xx	ABC-DEF	1.000	2.810	Undivided	06-05-17	9.98341	78.03004
NH00xx	ABC-DEF	2.810	4.335	Undivided	06-05-17	9.98107	78.03078
NH00xx	ABC-DEF	4.335	6.666	Undivided	06-05-17	9.96328	78.04160
NH00xx	ABC-DEF	6.666	12.906	Undivided	06-05-17	9.95385	78.05255

### 1.3 Road Type

The following table lists the fields which need to be populated for the 'Road Type' attribute. The descriptions of the fields are given below.

Field	Description	Example
NHNumber	New National Highway number	NH0065
SectionCode	Code indicating starting and ending locations of section	HYD-VIJ (Hyderabad-Vijayawada)
StartChainage	Chainage of the start point (in km)	0.500
EndChainage	Chainage of the end point (in km)	1.500
RoadType	Classification of road on basis of number of lanes <ul style="list-style-type: none"> <li>• Single Lane</li> <li>• Two Lane</li> <li>• Intermediate Lane</li> <li>• Four Lane</li> <li>• Six Lane</li> </ul>	Four Lane

Field	Description	Example
SurveyDate	Date of survey in the format <DD-MM-YY>	06-05-17
Latitude	Latitude of survey point	9.98897
Longitude	Longitude of survey point	78.02671

A sample output is shown below for reference:

NHNumber	Section	Start Chainage	End Chainage	RoadType	Date of Survey	Latitude	Longitude
NH00xx	ABC-DEF	0.000	0.794	Two Lane	06-05-17	9.98897	78.02671
NH00xx	ABC-DEF	0.794	1.000	Two Lane	06-05-17	9.98444	78.02934
NH00xx	ABC-DEF	1.000	2.810	Two Lane	06-05-17	9.98341	78.03004
NH00xx	ABC-DEF	2.810	4.335	Two Lane	06-05-17	9.98107	78.03078
NH00xx	ABC-DEF	4.335	6.666	Two Lane	06-05-17	9.96328	78.04160
NH00xx	ABC-DEF	6.666	12.906	Two Lane	06-05-17	9.95385	78.05255

#### 1.4 Pavement Type

The following table lists the fields which need to be populated for the 'Pavement Type' attribute. The descriptions of the fields are given below.

Field	Description	Example
NHNumber	New National Highway number	NH0065
SectionCode	Code indicating starting and ending locations of section	HYD-VIJ (Hyderabad-Vijayawada)
StartChainage	Chainage of the start point (in km)	0.500
EndChainage	Chainage of the end point (in km)	1.500
Direction	Direction of survey <ul style="list-style-type: none"> <li>Increasing (chainage)</li> <li>Decreasing (chainage)</li> </ul>	Increasing
PavementType	Classification of pavement based on type of surface: <ul style="list-style-type: none"> <li>Asphalt</li> </ul>	Asphalt

Field	Description	Example
	<ul style="list-style-type: none"> <li>Cement concrete</li> </ul>	
SurveyDate	Date of survey in the format <DD-MM-YY>	06-05-17
Latitude	Latitude of survey point	9.98897
Longitude	Longitude of survey point	78.02671

A sample output is shown below for reference:

NHNumber	Section	Start Chainage	End Chainage	Direction	Pavement Type	Date of Survey	Latitude	Longitude
NH00xx	ABC-DEF	0.000	0.804	Both	Asphalt	06-05-17	9.98897	78.02671
NH00xx	ABC-DEF	0.804	1.000	Both	Asphalt	06-05-17	9.98444	78.02934
NH00xx	ABC-DEF	1.000	1.172	Both	Asphalt	06-05-17	9.98341	78.03004
NH00xx	ABC-DEF	1.172	2.821	Both	Asphalt	06-05-17	9.98107	78.03078
NH00xx	ABC-DEF	2.821	4.350	Both	Asphalt	06-05-17	9.96328	78.04160
NH00xx	ABC-DEF	4.350	6.710	Both	Asphalt	06-05-17	9.95385	78.05255
NH00xx	ABC-DEF	6.710	12.925	Both	Asphalt	06-05-17	9.93102	78.05648

### 1.5 Pavement Width

The following table lists the fields which need to be populated for the 'Pavement Width' attribute. The descriptions of the fields are given below.

Field	Description	Example
NHNumber	New National Highway number	NH0065
SectionCode	Code indicating starting and ending locations of section	HYD-VIJ (Hyderabad-Vijayawada)
StartChainage	Chainage of the start point (in km)	0.500
EndChainage	Chainage of the end point (in km)	1.500
Direction	Direction of survey <ul style="list-style-type: none"> <li>Increasing (chainage)</li> <li>Decreasing (chainage)</li> </ul>	Increasing

Field	Description	Example
PavementWidth	Width of the pavement in metres, classified into one of the below categories <ul style="list-style-type: none"> <li>• <math>\geq 3.75\text{m}</math> and <math>&lt; 5.5\text{m}</math></li> <li>• <math>&gt;5.5\text{m}</math> and <math>&lt; 7\text{m}</math></li> <li>• <math>\geq 7\text{m}</math> and <math>&lt; 10.5\text{m}</math></li> <li>• <math>\geq 10.5\text{m}</math> and <math>\leq 12.5\text{m}</math></li> <li>• <math>&gt; 12.5\text{m}</math></li> </ul>	$>7\text{m}$ and $<10.5\text{m}$
PavementWidthValue	Width of the pavement in metres, rounded to two places after decimal	7.0
SurveyDate	Date of survey in the format <DD-MM-YY>	06-05-17
Latitude	Latitude of survey point	9.98897
Longitude	Longitude of survey point	78.02671

A sample output is shown below for reference:

NH Number	Section Code	Start Chainage	End Chainage	Direction	Pavement Width	Pavement Width Value	Survey Date	Latitude	Longitude
NH00xx	ABC-DEF	0.000	0.794	Both	7 - 10.5 m	7.00	06-05-17	9.98897	78.02671
NH00xx	ABC-DEF	0.794	1.000	Both	7 - 10.5 m	7.00	06-05-17	9.98444	78.02934
NH00xx	ABC-DEF	1.000	2.810	Both	7 - 10.5 m	7.00	06-05-17	9.98341	78.03004
NH00xx	ABC-DEF	2.810	4.335	Both	7 - 10.5 m	7.00	06-05-17	9.98107	78.03078
NH00xx	ABC-DEF	4.335	6.666	Both	7 - 10.5 m	7.00	06-05-17	9.96328	78.04160
NH00xx	ABC-DEF	6.666	12.906	Both	7 - 10.5 m	7.00	06-05-17	9.95385	78.05255

## 1.6 Shoulder Type

The following table lists the fields which need to be populated for the 'Shoulder Type' attribute. The descriptions of the fields are given below.

Field	Description	Example
NHNumber	New National Highway number	NH0065
SectionCode	Code indicating starting and ending locations of section	HYD-VIJ (Hyderabad-Vijayawada)

Field	Description	Example
StartChainage	Chainage of the start point (in km)	0.500
EndChainage	Chainage of the end point (in km)	1.500
Direction	Direction of survey <ul style="list-style-type: none"> <li>Increasing (chainage)</li> <li>Decreasing (chainage)</li> </ul>	Increasing
ShoulderType	Type of shoulder, classified into one of the below categories: <ul style="list-style-type: none"> <li>None</li> <li>Paved</li> <li>Gravel</li> <li>Earth</li> </ul>	Gravel
SurveyDate	Date of survey in the format <DD-MM-YY>	06-05-17
Latitude	Latitude of survey point	9.98897
Longitude	Longitude of survey point	78.02671

A sample output is shown below for reference:

NH Number	Section Code	Start Chainage	End Chainage	Direction	ShoulderType	Survey Date	Latitude	Longitude
NH00xx	ABC-DEF	0.000	0.763	Increasing	No Shoulder	09-01-16	9.98897	78.02671
NH00xx	ABC-DEF	0.763	0.834	Increasing	Gravel	09-01-16	9.98444	78.02934
NH00xx	ABC-DEF	0.834	1.254	Increasing	Gravel	09-01-16	9.98341	78.03004
NH00xx	ABC-DEF	1.254	2.945	Increasing	Gravel	05-01-16	9.98107	78.03078
NH00xx	ABC-DEF	2.945	4.327	Increasing	Gravel	05-01-16	9.96328	78.04160
NH00xx	ABC-DEF	4.327	4.405	Increasing	Gravel	05-01-16	9.95385	78.05255
NH00xx	ABC-DEF	4.405	6.844	Increasing	Gravel	05-01-16	9.93102	78.05648
NH00xx	ABC-DEF	6.844	9.359	Increasing	Gravel	05-01-16	9.91229	78.04961
NH00xx	ABC-DEF	9.359	12.966	Increasing	Gravel	05-01-16	9.89041	78.03458

## 1.7 ShoulderWidth

The following table lists the fields for the 'Shoulder Width' attribute, which need to be populated. The descriptions of the fields are given below.

Field	Description	Example
NHNumber	New National Highway number	NH0065
SectionCode	Code indicating starting and ending locations of section	HYD-VIJ (Hyderabad-Vijayawada)
StartChainage	Chainage of the start point (in km)	0.500
EndChainage	Chainage of the end point (in km)	1.500
Direction	Direction of survey <ul style="list-style-type: none"> <li>Increasing (chainage)</li> <li>Decreasing (chainage)</li> </ul>	Increasing
ShoulderWidth	Width of the shoulder in metres, classified into one of the below categories <ul style="list-style-type: none"> <li>No shoulder</li> <li>&lt; 1m</li> <li>&gt;= 1m and &lt;= 2m</li> <li>&gt; 2m</li> </ul>	< 1m
ShoulderWidthValue	Width of the shoulder in metres, rounded to one place after decimal	0.5
SurveyDate	Date of survey in the format <DD-MM-YY>	06-05-17
Latitude	Latitude of survey point	9.98897
Longitude	Longitude of survey point	78.02671

A sample output is shown below for reference:

NH Number	Section Code	Start Chainage	End Chainage	Direction	Shoulder Width	Shoulder Width Value	Survey Date	Latitude	Longitude
NH0xxx	ABC-DEF	0.000	0.785	Increasing	No Shoulder	0.0	03-01-16	9.98897	78.02671
NH0xxx	ABC-DEF	0.785	2.612	Increasing	No Shoulder	0.0	03-01-16	9.98444	78.02934
NH0xxx	ABC-DEF	2.612	3.170	Increasing	1-2m	2.0	03-01-16	9.98341	78.03004
NH0xxx	ABC-DEF	3.170	5.194	Increasing	1-2m	2.0	03-01-16	9.98107	78.03078
NH0xxx	ABC-DEF	5.194	6.793	Increasing	1-2m	2.0	03-01-16	9.96328	78.04160
NH0xxx	ABC-DEF	6.793	11.404	Increasing	1-2m	2.0	03-01-16	9.95385	78.05255

## 1.8 Topography

The following table lists the fields which need to be populated for the ‘Topography’ attribute. The descriptions of the fields are given below.

Field	Description	Example
NHNumber	New National Highway number	NH0065
SectionCode	Code indicating starting and ending locations of section	HYD-VIJ (Hyderabad-Vijayawada)
StartChainage	Chainage of the start point (in km)	0.500
EndChainage	Chainage of the end point (in km)	1.500
Topography	Topography of the road, classified into one of the below categories <ul style="list-style-type: none"> <li>• Flat</li> <li>• Rolling</li> <li>• Hilly</li> </ul>	Flat
SurveyDate	Date of survey in the format <DD-MM-YY>	06-05-17
Latitude	Latitude of survey point	9.98897
Longitude	Longitude of survey point	78.02671

A sample output is shown below for reference:

NH Number	Section Code	Start Chainage	End Chainage	Topography	Survey Date	Latitude	Longitude
NH0xxx	ABC-DEF	0.000	0.808	Flat	05-01-16	9.98897	78.02671
NH0xxx	ABC-DEF	0.808	1.254	Flat	05-01-16	9.98444	78.02934
NH0xxx	ABC-DEF	1.254	2.828	Flat	05-01-16	9.98341	78.03004
NH0xxx	ABC-DEF	2.828	4.363	Flat	05-01-16	9.98107	78.03078
NH0xxx	ABC-DEF	4.363	6.724	Flat	05-01-16	9.96328	78.04160
NH0xxx	ABC-DEF	6.724	12.933	Flat	05-01-16	9.95385	78.05255

## 1.9 Cross Section

The following table lists the fields which need to be populated for the ‘Cross Section’ attribute. The descriptions of the fields are given below.

Field	Description	Example
NHNumber	New National Highway number	NH0065
SectionCode	Code indicating starting and ending locations of section	HYD-VIJ (Hyderabad-Vijayawada)
StartChainage	Chainage of the start point (in km)	0.500
EndChainage	Chainage of the end point (in km)	1.500
Direction	Direction of survey <ul style="list-style-type: none"> <li>Increasing (chainage)</li> <li>Decreasing (chainage)</li> </ul>	Increasing
CrossSection	Cross section type, classified into one of the below categories <ul style="list-style-type: none"> <li>Cut</li> <li>Fill</li> <li>Cut and Fill</li> <li>Level</li> </ul>	Fill
Survey	Date of survey in the format <DD-MM-YY>	06-05-17
Latitude	Latitude of survey point	9.98897
Longitude	Longitude of survey point	78.02671

A sample output is shown below for reference:

NH Number	Section Code	Start Chainage	End Chainage	Direction	Cross Section	Survey Date	Latitude	Longitude
NH0xxx	ABC-DEF	0.000	0.822	Increasing	Level	03-01-16	9.98897	78.02671
NH0xxx	ABC-DEF	0.822	2.642	Increasing	Level	03-01-16	9.98444	78.02934
NH0xxx	ABC-DEF	2.642	3.199	Increasing	Level	03-01-16	9.98341	78.03004
NH0xxx	ABC-DEF	3.199	5.360	Increasing	Level	03-01-16	9.98107	78.03078
NH0xxx	ABC-DEF	5.360	5.715	Increasing	Fill	03-01-16	9.96328	78.04160
NH0xxx	ABC-DEF	5.715	6.941	Increasing	Level	03-01-16	9.95385	78.05255
NH0xxx	ABC-DEF	6.941	11.163	Increasing	Level	03-01-16	9.93102	78.05648

## 1.10 Drain Type

The following table lists the fields which need to be populated for the 'Drain Type' attribute. The descriptions of the fields are given below.

Field	Description	Example
NHNumber	New National Highway number	NH0065
SectionCode	Code indicating starting and ending locations of section	HYD-VIJ (Hyderabad-Vijayawada)
StartChainage	Chainage of the start point (in km)	0.500
EndChainage	Chainage of the end point (in km)	1.500
Direction	Direction of survey <ul style="list-style-type: none"> <li>Increasing (chainage)</li> <li>Decreasing (chainage)</li> </ul>	Increasing
DrainType	Type of drain, classified into one of the below categories <ul style="list-style-type: none"> <li>Open unlined drain</li> <li>Open lined drain</li> <li>Covered line drain</li> <li>No drain</li> </ul>	Open lined drain
SurveyDate	Date of survey in the format <DD-MM-YY>	06-05-17
Latitude	Latitude of survey point	9.98897
Longitude	Longitude of survey point	78.02671

A sample output is shown below for reference:

NHNumber	SectionCode	StartChainage	EndChainage	Direction	DrainType	SurveyDate	Latitude	Longitude
NH0xxx	ABC-DEF	0.000	0.069	Increasing	Open Unlined Drain	09-01-16	9.98897	78.02671
NH0xxx	ABC-DEF	0.069	0.782	Increasing	Open Lined Drain	09-01-16	9.98444	78.02934
NH0xxx	ABC-DEF	0.288	0.000	Decreasing	Open Unlined Drain	09-01-16	9.98341	78.03004
NH0xxx	ABC-DEF	0.782	0.846	Increasing	Open Unlined Drain	09-01-16	9.98107	78.03078
NH0xxx	ABC-DEF	0.846	1.254	Increasing	Open Unlined	09-01-16	9.96328	78.04160

NHNumber	SectionCode	StartChainage	EndChainage	Direction	DrainType	SurveyDate	Latitude	Longitude
					Drain			
NH0xxx	ABC-DEF	1.254	2.265	Increasing	Open Unlined Drain	05-01-16	9.95385	78.05255
NH0xxx	ABC-DEF	1.929	0.288	Decreasing	Open Unlined Drain	09-01-16	9.93102	78.05648
NH0xxx	ABC-DEF	1.952	1.929	Decreasing	No Drain	09-01-16	9.91229	78.04961
NH0xxx	ABC-DEF	2.265	3.005	Increasing	Open Unlined Drain	05-01-16	9.89041	78.03458
NH0xxx	ABC-DEF	2.680	1.952	Decreasing	Open Unlined Drain	09-01-16	9.88489	78.02995
NH0xxx	ABC-DEF	3.005	4.424	Increasing	Open Unlined Drain	05-01-16	9.87474	78.02828
NH0xxx	ABC-DEF	3.109	2.680	Decreasing	Open Unlined Drain	09-01-16	9.87363	78.02744
NH0xxx	ABC-DEF	3.320	3.109	Decreasing	Covered Line Drain	09-01-16	9.84857	78.01535
NH0xxx	ABC-DEF	3.917	3.320	Decreasing	Open Unlined Drain	09-01-16	9.83764	78.00392
NH0xxx	ABC-DEF	4.424	4.601	Increasing	Open Unlined Drain	05-01-16	9.83711	77.98576
NH0xxx	ABC-DEF	4.601	5.693	Increasing	Open Unlined Drain	05-01-16	9.83386	77.97729

### 1.11 Median Opening

The following table lists the fields which need to be populated for the 'Median Opening' attribute. The descriptions of the fields are given below.

Field	Description	Example
NHNumber	New National Highway number	NH0065
SectionCode	Code indicating starting and ending locations of section	HYD-VIJ (Hyderabad-Vijayawada)
StartChainage	Chainage of the start point (in km)	0.500

Field	Description	Example
EndChainage	Chainage of the end point (in km)	1.500
Direction	Direction of survey <ul style="list-style-type: none"> <li>Increasing (chainage)</li> <li>Decreasing (chainage)</li> </ul>	Increasing
MedianType	Type of median, classified into one of the below categories <ul style="list-style-type: none"> <li>Raised;</li> <li>Depressed;</li> <li>Barrier;</li> <li>None.</li> </ul>	Raised
MedianWidth	Width of the median in metres, rounded to one place after decimal	0.5
SurveyDate	Date of survey in the format <DD-MM-YY>	06-05-17
Latitude	Latitude of survey point	9.98897
Longitude	Longitude of survey point	78.02671

A sample output is shown below for reference:

NHNumber	Section Code	Start Chainage	End Chainage	Direction	Median Type	Median Width	Survey Date	Latitude	Longitude
NH00xx	ABC-DEF	0.000	0.794	Both	Raised	0.5	05-01-16	9.98897	78.02671
NH00xx	ABC-DEF	0.794	1.000	Both	Raised	0.5	05-01-16	9.98444	78.02934
NH00xx	ABC-DEF	1.000	2.810	Both	No Median	0.0	05-01-16	9.98341	78.03004
NH00xx	ABC-DEF	2.810	4.335	Both	Raised	1.5	05-01-16	9.98107	78.03078
NH00xx	ABC-DEF	4.335	6.666	Both	No Median	0.0	05-01-16	9.96328	78.04160
NH00xx	ABC-DEF	6.666	12.906	Both	No Median	0.0	05-01-16	9.95385	78.05255

### 1.12 Right Of Way

The following table lists the fields which need to be populated for the 'Right of Way' attribute. The descriptions of the fields are given below.

Field	Description	Example
-------	-------------	---------

Field	Description	Example
NHNumber	New National Highway number	NH0065
SectionCode	Code indicating starting and ending locations of section	HYD-VIJ (Hyderabad-Vijayawada)
StartChainage	Chainage of the start point (in km)	0.500
EndChainage	Chainage of the end point (in km)	1.500
Direction	Direction of survey <ul style="list-style-type: none"> <li>Increasing (chainage)</li> <li>Decreasing (chainage)</li> </ul>	Increasing
RowWidth	Width of Right of Way (in metres)	24
Remarks		
SurveyDate	Date of survey in the format <DD-MM-YY>	06-05-17
Latitude	Latitude of survey point	9.98897
Longitude	Longitude of survey point	78.02671

A sample output is shown below for reference:

NHNumber	Section Code	Start Chainage	End Chainage	Direction	ROW Width	Remarks	Survey Date	Latitude	Longitude
NH0xxx	ABC-DEF	0.000	1.000	Increasing	28		05-05-15	9.98897	78.02671
NH0xxx	ABC-DEF	1.000	2.000	Increasing	24		05-05-15	9.98444	78.02934
NH0xxx	ABC-DEF	2.000	3.000	Increasing	30		05-05-15	9.98341	78.03004
NH0xxx	ABC-DEF	3.000	4.000	Increasing	26		05-05-15	9.98107	78.03078
NH0xxx	ABC-DEF	4.000	11.000	Increasing	24		05-05-15	9.96328	78.04160

### 1.13 Pavement composition

The following table lists the fields which need to be populated for the 'Pavement composition' attribute. The descriptions of the fields are given below.

Field	Description	Example
NHNumber	New National Highway number	NH0065
SectionCode	Code indicating starting and ending locations of section	HYD-VIJ (Hyderabad-Vijayawada)

Field	Description	Example
StartChainage	Chainage of the start point (in km)	0.500
EndChainage	Chainage of the end point (in km)	1.500
Direction	Direction of survey <ul style="list-style-type: none"> <li>Increasing (chainage)</li> <li>Decreasing (chainage)</li> </ul>	Increasing
PavementType	Type of pavement <ul style="list-style-type: none"> <li>Asphalt</li> <li>Cement concrete</li> </ul>	Asphalt
BituminousSurfaceCourseType	Type of bituminous surface course	BC
BituminousSurfaceCourseThicknessM	Thickness of BSC layer in mm	40
BSCConstructionYear	Year of construction of BSC layer in flexible pavements	2015
BituminousBaseCourseType	Type of bituminous base course	DBM
BituminousBaseCourseThickness	Thickness of BBC layer in mm	100
BBCConstructionYear	Year of construction of BBC layer in flexible pavements	2015
GranularBaseType	Type of granular base	WMM
GranularBaseThickness	Thickness of GB layer in mm	250
GBConstructionYear	Year of construction of GB layer in flexible pavements	2015
PavementQualityConcreteType	Type of pavement quality concrete	PQC
PavementQualityConcreteThickness	Thickness of PQC layer in mm	300
PQCConstructionYear	Year of construction of PQC layer in rigid pavements	2015
DryLeanConcreteT	Thickness of DLC layer in mm	100

Field	Description	Example
hicknessMM		
DryLeanConcreteType	Type of dry lean concrete	DLC
DLCConstructionYear	Year of construction of DLC layer in rigid pavements	2015
GranularSubBaseType	Type of granular sub base	GSB
GranularSubBaseThickness	Thickness of GSB layer in mm	200
GSBConstructionYear	Year of construction of GSB layer	2014
DesignCBR	Design CBR of the subgrade, expressed in %	5%
SurveyDate	Date of survey in the format <DD-MM-YY>	06-05-17
Latitude	Latitude of survey point	9.98897
Longitude	Longitude of survey point	78.02671

A sample output is shown below for reference:

NH No.	Section Code	Start Chainage	End Chainage	Direction	Pavement Type	Bituminous Surface Course Type	Bituminous Surface Course Thickness	BSC Construction Year	Bituminous Base Course Type	Bituminous Base Course Thickness	BBC Construction Year	Granular Base Type	Granular Base Thickness
NH00xx	ABC-DEF	0.0	5.0	Both side	Asphalt	BC	40.0	2015	DBM	100	2015	WMM	250
NH00xx	ABC-DEF	5.0	11.0	Both side	Asphalt	BC	40.0	2015	DBM	80	2015	WMM	250
NH00xx	ABC-DEF	11.0	20.0	Both side	Asphalt	SDBC	25.0	2015	BM	115	2015	WMM	250
NH00xx	ABC-DEF	20.0	22.0	Both side	Asphalt	BC	40.0	2015	DBM	100	2015	WMM	250
NH00xx	ABC-DEF	22.0	30.0	Both side	Asphalt	SDBC	25.0	2015	BM	115	2015	WMM	250
NH00xx	ABC-DEF	30.0	31.0	Both side	Asphalt	BC	40.0	2015	DBM	100	2015	WMM	250

(table continued...)

GB Construction Year	Pavement Quality Concrete Type	Pavement Quality Concrete Thickness	PQC Construction Year	Dry Lean Concrete Thickness	Dry Lean Concrete Type	DLC Construction Year	Granular SubBase Type	Granular SubBase Thickness	GSB Construction Year	Design CBR	Survey Date	Latitude	Longitude
2015	NA	NA	NA	NA	NA	NA	GSB	300	2015	5%	05-05-15	9.99	78.03
2015	NA	NA	NA	NA	NA	NA	GSB	300	2015	5%	05-05-15	9.98	78.03
2015	NA	NA	NA	NA	NA	NA	GSB	300	2015	5%	05-05-15	9.98	78.03
2015	NA	NA	NA	NA	NA	NA	GSB	300	2015	5%	05-05-15	9.98	78.03
2015	NA	NA	NA	NA	NA	NA	GSB	300	2015	5%	05-05-15	9.96	78.04
2015	NA	NA	NA	NA	NA	NA	GSB	300	2015	5%	05-05-15	9.95	78.05

### 1.14 Carriageway Furniture

The following table lists the fields which need to be populated for the 'Carriageway Furniture' attribute. The descriptions of the fields are given below.

Field	Description	Example
NHNumber	New National Highway number	NH0065
SectionCode	Code indicating starting and ending locations of section	HYD-VIJ (Hyderabad-Vijayawada)
Chainage	Chainage of the point (in km)	0.500
Direction	Direction of survey <ul style="list-style-type: none"> <li>Increasing (chainage)</li> <li>Decreasing (chainage)</li> </ul>	Increasing
Wayside Amenity Type	Wayside amenities classified into one of the below categories: <ul style="list-style-type: none"> <li>Crash barriers</li> <li>Signs</li> <li>Street Lights</li> <li>Km stone</li> </ul>	Road sign
SurveyDate	Date of survey in the format <DD-MM-YY>	06-05-17
Latitude	Latitude of survey point	9.98897
Longitude	Longitude of survey point	78.02671

A sample output is shown below for reference:

NHNumber	SectionCode	Chainage	Direction	EventType	SurveyDate	Latitude	Longitude
NH00xx	ABC-DEF	0.012	Increasing	Street Light Start	03-01-16	9.98897	78.02671
NH00xx	ABC-DEF	0.287	Increasing	Street Light End	03-01-16	9.98444	78.02934
NH00xx	ABC-DEF	2.491	Decreasing	Road Sign	03-01-16	9.98341	78.03004
NH00xx	ABC-DEF	2.708	Decreasing	Road Sign	03-01-16	9.98107	78.03078
NH00xx	ABC-DEF	3.496	Increasing	Road Sign	03-01-16	9.96328	78.04160
NH00xx	ABC-DEF	5.160	Increasing	Road Sign	03-01-16	9.95385	78.05255
NH00xx	ABC-DEF	5.356	Decreasing	Road Sign	03-01-16	9.93102	78.05648
NH00xx	ABC-DEF	8.402	Decreasing	Road Sign	03-01-16	9.91229	78.04961
NH00xx	ABC-DEF	10.966	Decreasing	Road Sign	03-01-16	9.89041	78.03458

### 1.15 Wayside Amenities

The following table lists the fields which need to be populated for the ‘Wayside Amenities’ attribute. The descriptions of the fields are given below.

Field	Description	Example
NHNumber	New National Highway number	NH0065
SectionCode	Code indicating starting and ending locations of section	HYD-VIJ (Hyderabad-Vijayawada)
Chainage	Chainage of the point (in km)	0.500
Direction	Direction of survey <ul style="list-style-type: none"> <li>Increasing (chainage)</li> <li>Decreasing (chainage)</li> </ul>	Increasing
Wayside Amenity	Wayside amenities classified into one of the below categories: <ul style="list-style-type: none"> <li>Bus shelter;</li> <li>Culverts;</li> <li>Restaurant/Motel;</li> <li>Toilet/Public convenience;</li> <li>Rest Rooms for short stay;</li> </ul>	Restaurant/Motel

Field	Description	Example
	<ul style="list-style-type: none"> <li>Toll Plaza;</li> <li>First aid/Medical centre;</li> <li>Telephone booth;</li> <li>Petrol pump/minor repair shop (optional);</li> <li>Police Station;</li> <li>Temple /Mosque;</li> <li>Bridges.</li> </ul>	
SurveyDate	Date of survey in the format <DD-MM-YY>	06-05-17
DataSource		
Remarks		
Latitude	Latitude of survey point	9.98897
Longitude	Longitude of survey point	78.02671

A sample output is shown below for reference:

NH Number	Section Code	Chainage	Direction	Wayside Amenity	Survey Date	Data Source	Remarks	Latitude	Longitude
NH00xx	ABC-DEF	0.650	Increasing	Restaurant/Motel	05-01-16			9.98897	78.02671
NH00xx	ABC-DEF	1.998	Increasing	Restaurant/Motel	05-01-16			9.98444	78.02934
NH00xx	ABC-DEF	5.524	Increasing	Petrol Pump	05-01-16			9.98341	78.03004
NH00xx	ABC-DEF	11.413	Increasing	Restaurant/Motel	05-01-16			9.98107	78.03078

### 1.16 Land Use

The following table lists the fields which need to be populated for the 'Land Use' attribute. The descriptions of the fields are given below.

Field	Description	Example
NHNumber	New National Highway number	NH0065
SectionCode	Code indicating starting and ending locations of section	HYD-VIJ (Hyderabad-Vijayawada)
StartChainage	Chainage of the start point (in km)	0.500

Field	Description	Example
EndChainage	Chainage of the end point (in km)	1.500
Direction	Direction of survey <ul style="list-style-type: none"> <li>Increasing (chainage)</li> <li>Decreasing (chainage)</li> </ul>	Increasing
LandUse	Land use classified into one of the below categories: <ul style="list-style-type: none"> <li>Residential;</li> <li>Commercial;</li> <li>Industrial;</li> <li>Agricultural;</li> <li>Water bodies;</li> <li>Mixed.</li> </ul>	Commercial
SurveyDate	Date of survey in the format <DD-MM-YY>	06-05-17
Latitude	Latitude of survey point	9.98897
Longitude	Longitude of survey point	78.02671

A sample output is shown below for reference:

NHNumber	SectionCode	StartChainage	EndChainage	Direction	LandUse	SurveyDate	Latitude	Longitude
NH00xx	ABC-DEF	0.000	0.797	Increasing	Mixed	03-01-16	9.98897	78.02671
NH00xx	ABC-DEF	0.511	0	Decreasing	Mixed	03-01-16	9.98444	78.02934
NH00xx	ABC-DEF	0.797	2.699	Increasing	Mixed	03-01-16	9.98341	78.03004
NH00xx	ABC-DEF	0.835	0.511	Decreasing	Mixed	03-01-16	9.98107	78.03078
NH00xx	ABC-DEF	0.987	0.835	Decreasing	Mixed	03-01-16	9.96328	78.04160
NH00xx	ABC-DEF	1.641	0.987	Decreasing	Agriculture	03-01-16	9.95385	78.05255
NH00xx	ABC-DEF	2.081	1.641	Decreasing	Barren Land	03-01-16	9.93102	78.05648
NH00xx	ABC-DEF	2.378	2.081	Decreasing	Agriculture	03-01-16	9.91229	78.04961
NH00xx	ABC-DEF	2.458	2.378	Decreasing	Agriculture	03-01-16	9.89041	78.03458
NH00xx	ABC-DEF	2.699	3.234	Increasing	Agriculture	03-01-16	9.88489	78.02995

## SECTION 2 - ROAD CONDITION DATA

Road condition data consists of parameters which directly affect maintenance requirements of the road. These parameters are dynamic in nature, and therefore a survey to update this dataset shall be conducted annually for FWD testing and every six months as per Annexure IV for network survey vehicle testing. The first survey shall be conducted within 30 days of appointment of the Independent Engineer and the remaining surveys shall be conducted as per the defined frequency.

As an example, if majority of highway length (>50%) passes through a state, where defined survey months are May and November, if appointed date is on 1<sup>st</sup> March, then the first network survey shall be conducted in the month of March within 30 days of appointment and this shall be considered as the network survey to be conducted in the month of May. The 2<sup>nd</sup> survey shall be conducted in the month of November, the 3<sup>rd</sup> survey shall be conducted in the month of May and so on. As regards FWD, the first test/survey shall be conducted in the month of March within 30 days of appointment. The 2<sup>nd</sup> test/survey shall be conducted in March of next year and so on.

The road condition data shall be used to update specific worksheets, which are listed below.

## 2.1 Visual condition

The following table lists the fields which need to be populated for the ‘Visual Condition’ attribute. The descriptions of the fields are given below.

Field	Description	Example
NHNumber	New National Highway number	NH0065
SectionCode	Code indicating starting and ending locations of section	HYD-VIJ (Hyderabad-Vijayawada)
StartChainage	Chainage of the start point (in km)	0.500
EndChainage	Chainage of the end point (in km)	1.500
Direction	Direction of survey <ul style="list-style-type: none"> <li>Increasing (chainage)</li> <li>Decreasing (chainage)</li> </ul>	Increasing
LaneNumber	Number of the lane: L1, L2, R1, R2, etc., L1 being 1 <sup>st</sup> lane on the left from centreline of carriageway, L2 being 2 <sup>nd</sup> lane on the left from centerline and so on	L1
Ravelling	Percent of pavement area affected by ravelling, which is converted to the following rating scale: <ul style="list-style-type: none"> <li>1 - Very Poor (&gt; 30%)</li> </ul>	2

Field	Description	Example
	<ul style="list-style-type: none"> <li>• 2 - Poor (11-30%)</li> <li>• 3 - Fair (6-10%)</li> <li>• 4 - Good (1-5%)</li> <li>• 5 - Very Good (0%)</li> </ul>	
PotHoles	No. of potholes, which is converted to the following rating scale: <ul style="list-style-type: none"> <li>• 1 - Very Poor (&gt; 5)</li> <li>• 2 - Poor (3-5)</li> <li>• 3 - Fair (2)</li> <li>• 4 - Good (1)</li> <li>• 5 - Very Good (0)</li> </ul>	1
EdgeBreak	Pavement area containing edge breaks, which is converted to the following rating scale: <ul style="list-style-type: none"> <li>• 1 - Very Poor (&gt; 5m<sup>2</sup>)</li> <li>• 2 - Poor (1-5m<sup>2</sup>)</li> <li>• 3 - Fair (0.5-1m<sup>2</sup>)</li> <li>• 4 - Good (0-0.5m<sup>2</sup>)</li> <li>• 5 - Very Good (0m<sup>2</sup>)</li> </ul>	3
Cracking	Percent of pavement area affected by cracking, which is converted to the following rating scale: <ul style="list-style-type: none"> <li>• 1 - Very Poor (&gt; 30%)</li> <li>• 2 - Poor (21-30%)</li> <li>• 3 - Fair (11-20%)</li> <li>• 4 - Good (5-10%)</li> <li>• 5 - Very Good (&lt;5%)</li> </ul>	3
Disintegration	Percent of pavement area affected by disintegration, which is converted to the following rating scale: <ul style="list-style-type: none"> <li>• 1 - Very Poor (&gt; 50%)</li> <li>• 2 - Poor (20-50%)</li> <li>• 3 - Fair (10-20%)</li> <li>• 4 - Good (1-10%)</li> <li>• 5 - Very Good (&lt;1%)</li> </ul>	2
Depression	Percent of pavement area affected by depression, which is converted to the following rating scale: <ul style="list-style-type: none"> <li>• 1 - Very Poor (&gt; 5%)</li> <li>• 2 - Poor (3-5%)</li> </ul>	5

Field	Description	Example
	<ul style="list-style-type: none"> <li>3 - Fair (1-2%)</li> <li>4 - Good (0-1%)</li> <li>5 - Very Good (0)</li> </ul>	
Bleeding	Percent of pavement area affected by bleeding, which is converted to the following rating scale: <ul style="list-style-type: none"> <li>1 - Very Poor (&gt; 50%)</li> <li>2 - Poor (20-50%)</li> <li>3 - Fair (10-20%)</li> <li>4 - Good (1-10%)</li> <li>5 - Very Good (&lt;1%)</li> </ul>	3
Patching	Percent of pavement area affected by patching, which is converted to the following rating scale: <ul style="list-style-type: none"> <li>1 - Very Poor (&gt; 30%)</li> <li>2 - Poor (16-30%)</li> <li>3 - Fair (6-15%)</li> <li>4 - Good (2-5%)</li> <li>5 - Very Good (&lt;2%)</li> </ul>	4
DrainCondition	Condition of the drain, which is converted to the following rating scale: <ul style="list-style-type: none"> <li>1 - Poor</li> <li>2 - Fair</li> <li>3 - Good</li> </ul>	2
ShoulderCondition	Condition of the shoulder, which is converted to the following rating scale: <ul style="list-style-type: none"> <li>1 - Poor</li> <li>2 - Fair</li> <li>3 - Good</li> </ul>	Fair
SurveyDate	Date of survey in the format <DD-MM-YY>	06-05-17
Latitude	Latitude of survey point	9.98897
Longitude	Longitude of survey point	78.02671

A sample output is shown below for reference:

NHNumber	Section	Start Chainage	End Chainage	Direction	Lane Number	Ravelling	PotHoles	EdgeBreak	Cracking
NH00xx	ABC-DEF	0.000	0.500	Increasing	L1	4	4	4	4

NHNumber	Section	Start Chainage	End Chainage	Direction	Lane Number	Ravelling	PotHoles	EdgeBreak	Cracking
NH00xx	ABC-DEF	0.500	1.000	Increasing	L1	4	4	4	5
NH00xx	ABC-DEF	1.000	1.500	Increasing	L1	5	5	4	5
NH00xx	ABC-DEF	1.500	2.000	Increasing	L1	5	5	5	5
NH00xx	ABC-DEF	2.000	2.500	Increasing	L1	5	5	5	5
NH00xx	ABC-DEF	2.500	3.000	Increasing	L1	5	5	4	5
NH00xx	ABC-DEF	3.000	3.500	Increasing	L1	5	5	4	5
NH00xx	ABC-DEF	3.500	4.000	Increasing	L1	5	4	3	5
NH00xx	ABC-DEF	4.000	4.500	Increasing	L1	4	4	4	5
NH00xx	ABC-DEF	4.500	5.000	Increasing	L1	5	5	4	5
NH00xx	ABC-DEF	5.000	5.500	Increasing	L1	5	5	4	5
NH00xx	ABC-DEF	5.500	6.000	Increasing	L1	5	5	4	5
NH00xx	ABC-DEF	6.000	6.500	Increasing	L1	5	5	4	5
NH00xx	ABC-DEF	6.500	7.000	Increasing	L1	5	5	4	5
NH00xx	ABC-DEF	7.000	7.500	Increasing	L1	5	5	5	5
NH00xx	ABC-DEF	7.500	8.000	Increasing	L1	5	5	4	5
NH00xx	ABC-DEF	8.000	8.500	Increasing	L1	5	5	4	5
NH00xx	ABC-DEF	8.500	9.000	Increasing	L1	5	5	4	5
NH00xx	ABC-DEF	9.000	9.500	Increasing	L1	5	5	4	5
NH00xx	ABC-DEF	9.500	10.000	Increasing	L1	5	5	3	5

(table continued...)

Disintegration	Depression	Bleeding	Patching	Drain Condition	ShoulderCondition	Date of Survey	Latitude	Longitude
4	4	4	4	2	2	06-05-17	9.98897	78.02671
4	4	4	4	2	2	06-05-17	9.98444	78.02934

Disintegration	Depression	Bleeding	Patching	Drain Condition	ShoulderCondition	Date of Survey	Latitude	Longitude
5	5	5	4	2	2	06-05-17	9.98341	78.03004
5	5	5	5	2	2	06-05-17	9.98107	78.03078
5	5	5	5	2	2	06-05-17	9.96328	78.04160
5	5	5	5	2	2	06-05-17	9.95385	78.05255
5	5	5	5	2	3	06-05-17	9.93102	78.05648
4	4	4	4	2	3	06-05-17	9.91229	78.04961
4	4	4	4	2	2	06-05-17	9.89041	78.03458
5	5	5	5	2	2	06-05-17	9.88489	78.02995
5	5	5	5	2	2	06-05-17	9.87474	78.02828
5	5	5	5	2	2	06-05-17	9.87363	78.02744
5	5	5	5	2	2	06-05-17	9.84857	78.01535
5	5	5	5	2	2	06-05-17	9.83764	78.00392
5	5	5	5	2	2	06-05-17	9.83711	77.98576
5	5	5	5	1	2	06-05-17	9.83386	77.97729
5	5	5	5	2	2	06-05-17	9.81804	77.97875
5	5	5	5	2	2	06-05-17	9.77426	77.98129
5	4	4	4	2	2	06-05-17	9.73071	77.97999
5	5	5	3	2	2	06-05-17	9.68686	77.97017

## 2.2 Roughness

The following table lists the fields which need to be populated for the 'Roughness' attribute. The descriptions of the fields are given below.

Field	Description	Example
NHNumber	New National Highway number	NH0065
SectionCode	Code indicating starting and ending locations of section	HYD-VIJ (Hyderabad-Vijayawada)

Field	Description	Example
StartChainage	Chainage of the start point (in km)	0.500
EndChainage	Chainage of the end point (in km)	1.500
Direction	Direction of survey <ul style="list-style-type: none"> <li>Increasing (chainage)</li> <li>Decreasing (chainage)</li> </ul>	Increasing
Lwplri	International roughness index (IRI) of left wheel path measured from laser profilometer	2.33
Rwplri	International roughness index (IRI) of right wheel path measured from laser profilometer	1.97
Lanelri	Average of the International roughness index (IRI) of left and right wheel paths	2.15
Speed	Speed of vehicle in km/h	42
SurveyDate	Date of survey in the format <DD-MM-YYYY>	06-05-17
Latitude	Latitude of survey point	9.98897
Longitude	Longitude of survey point	78.02671

A sample output is shown below for reference:

NH Number	Section Code	Start Chainage	End Chainage	Direction	Lane Number	Lwplri	Rwplri	Lanelri	Speed	Survey Date	Latitude	Longitude
NH00xx	ABC-DEF	0.0	0.1	Increasing	L1	3.31	5.16	4.24	20	06-05-17	9.98897	78.02671
NH00xx	ABC-DEF	0.1	0.2	Increasing	L1	2.81	3.54	3.18	37	06-05-17	9.98444	78.02934
NH00xx	ABC-DEF	0.2	0.3	Increasing	L1	2.31	1.92	2.12	42	06-05-17	9.98341	78.03004
NH00xx	ABC-DEF	0.3	0.4	Increasing	L1	2.17	2.37	2.27	46	06-05-17	9.98107	78.03078
NH00xx	ABC-DEF	0.4	0.5	Increasing	L1	2.11	1.72	1.92	42	06-05-17	9.96328	78.04160
NH00xx	ABC-DEF	0.5	0.6	Increasing	L1	2.33	1.97	2.15	49	06-05-17	9.95385	78.05255
NH00xx	ABC-DEF	0.6	0.7	Increasing	L1	2.37	2.00	2.19	42	06-05-17	9.93102	78.05648
NH Number	Section Code	Start Chainage	End Chainage	Direction	Lane Number	Lwplri	Rwplri	Lanelri	Speed	Survey Date	Latitude	Longitude
NH00xx	ABC-DEF	0.7	0.8	Increasing	L1	2.15	2.17	2.16	33	06-05-17	9.91229	78.04961

NH00xx	ABC-DEF	0.8	0.9	Increasing	L1	2.45	2.05	2.25	32	06-05-17	9.89041	78.03458
NH00xx	ABC-DEF	0.9	1.0	Increasing	L1	2.18	2.51	2.35	48	06-05-17	9.88489	78.02995

### 2.3 Rutting

The following table lists the fields which need to be populated for the ‘Rutting’ attribute. The descriptions of the fields are given below.

Field	Description	Example
NHNumber	New National Highway number	NH0065
SectionCode	Code indicating starting and ending locations of section	HYD-VIJ (Hyderabad-Vijayawada)
StartChainage	Chainage of the start point (in km)	0.500
EndChainage	Chainage of the end point (in km)	1.500
Direction	Direction of survey <ul style="list-style-type: none"> <li>Increasing (chainage)</li> <li>Decreasing (chainage)</li> </ul>	Increasing
LaneNumber	Number of the lane: L1, L2, R1, R2, etc., L1 being 1 <sup>st</sup> lane on the left from centreline of carriageway, L2 being 2 <sup>nd</sup> lane on the left from centerline and so on	L1
RuttingLeft	Rut depth in mm, measured from left wheel path	20
RuttingRight	Rut depth in mm, measured from left wheel path	18
RuttingAvg	Average rut depth measured from left and right wheel paths	19
Speed	Speed of vehicle in km/h	42
SurveyDate	Date of survey in the format <DD-MM-YYYY>	06-05-17
Latitude	Latitude of survey point	9.98897
Longitude	Longitude of survey point	78.02671

A sample output is shown below for reference:

NH Number	Section Code	Start Chainage	End Chainage	Direction	Lane Number	Rutting Left	Rutting Right	Rutting Avg	Speed	Survey Date	Latitude	Longitude
NH00xx	ABC-DEF	0.0	0.5	Increasing	L1	15	14	15	20	06-05-17	9.98897	78.02671

NH00xx	ABC-DEF	0.5	1.0	Increasing	L1	20	18	19	37	06-05-17	9.98444	78.02934
NH00xx	ABC-DEF	1.0	1.5	Increasing	L1	10	8	9	42	06-05-17	9.98341	78.03004
NH00xx	ABC-DEF	1.5	2.0	Increasing	L1	5	6	6	46	06-05-17	9.98107	78.03078
NH00xx	ABC-DEF	2.0	2.5	Increasing	L1	10	10	10	42	06-05-17	9.96328	78.04160
NH00xx	ABC-DEF	2.5	3.0	Increasing	L1	7	5	6	49	06-05-17	9.95385	78.05255
NH00xx	ABC-DEF	3.0	3.5	Increasing	L1	20	18	19	42	06-05-17	9.93102	78.05648
NH00xx	ABC-DEF	3.5	4.5	Increasing	L1	5	5	5	33	06-05-17	9.91229	78.04961
NH00xx	ABC-DEF	4.5	5.0	Increasing	L1	5	5	5	32	06-05-17	9.89041	78.03458

## 2.4 Texture Depth

The following table lists the fields which need to be populated for the 'Texture Depth' attribute. The descriptions of the fields are given below.

Field	Description	Example
NHNumber	New National Highway number	NH0065
SectionCode	Code indicating starting and ending locations of section	HYD-VIJ (Hyderabad-Vijayawada)
StartChainage	Chainage of the start point (in km)	0.500
EndChainage	Chainage of the end point (in km)	1.500
Direction	Direction of survey <ul style="list-style-type: none"> <li>Increasing (chainage)</li> <li>Decreasing (chainage)</li> </ul>	Increasing
LaneNumber	Number of the lane: L1, L2, R1, R2, etc., L1 being 1 <sup>st</sup> lane on the left from centreline of carriageway, L2 being 2 <sup>nd</sup> lane on the left from centerline and so on	L1
TextureLeft	Texture depth of pavement in mm, measured from left wheel path	0.40
TextureRight	Texture depth of pavement in mm, measured from left wheel path	0.30
TextureAverage	Average texture depth measured from left and right wheel paths	0.35
Speed	Speed of vehicle in km/h	42

Field	Description	Example
SurveyDate	Date of survey in the format <DD-MM-YYYY>	06-05-17
Latitude	Latitude of survey point	9.98897
Longitude	Longitude of survey point	78.02671

A sample output is shown below for reference:

NH Number	Section Code	Start Chainage	End Chainage	Direction	Lane Number	Texture Left	Texture Right	Texture Average	Speed	Survey Date	Latitude	Longitude
NH00xx	ABC-DEF	0.0	0.5	Increasing	L1	0.40	0.30	0.35	20	06-05-17	9.98897	78.02671
NH00xx	ABC-DEF	0.5	1.0	Increasing	L1	0.60	0.50	0.55	37	06-05-17	9.98444	78.02934
NH00xx	ABC-DEF	1.0	1.5	Increasing	L1	0.80	0.90	0.85	42	06-05-17	9.98341	78.03004
NH00xx	ABC-DEF	1.5	2.0	Increasing	L1	0.40	0.40	0.4	46	06-05-17	9.98107	78.03078
NH00xx	ABC-DEF	2.0	2.5	Increasing	L1	0.30	0.30	0.3	42	06-05-17	9.96328	78.04160
NH00xx	ABC-DEF	2.5	3.0	Increasing	L1	0.70	0.60	0.65	49	06-05-17	9.95385	78.05255
NH00xx	ABC-DEF	3.0	3.5	Increasing	L1	0.40	0.50	0.45	42	06-05-17	9.93102	78.05648
NH00xx	ABC-DEF	3.5	4.5	Increasing	L1	0.90	0.80	0.85	33	06-05-17	9.91229	78.04961
NH00xx	ABC-DEF	4.5	5.0	Increasing	L1	0.40	0.30	0.35	32	06-05-17	9.89041	78.03458

## 2.5 Skid Resistance

The following table lists the fields which need to be populated for the 'Skid Resistance' attribute. The descriptions of the fields are given below.

Field	Description	Example
NHNumber	New National Highway number	NH0065
SectionCode	Code indicating starting and ending locations of section	HYD-VIJ (Hyderabad-Vijayawada)
StartChainage	Chainage of the start point (in km)	0.500
EndChainage	Chainage of the end point (in km)	1.500
Direction	Direction of survey <ul style="list-style-type: none"> <li>Increasing (chainage)</li> </ul>	Increasing

Field	Description	Example
	<ul style="list-style-type: none"> <li>Decreasing (chainage)</li> </ul>	
LaneNumber	Number of the lane: L1, L2, R1, R2, etc., L1 being 1 <sup>st</sup> lane on the left from centreline of carriageway, L2 being 2 <sup>nd</sup> lane on the left from centerline and so on	L1
SkidLeft	Skid resistance of pavement measured as skid number, measured from left wheel path	25
SkidRight	Skid resistance of pavement measured as skid number, measured from left wheel path	24
SkidAverage	Average skid resistance measured from left and right wheel paths	24.5
Speed	Speed of vehicle in km/h	42
SurveyDate	Date of survey in the format <DD-MM-YYYY>	06-05-17
Latitude	Latitude of survey point	9.98897
Longitude	Longitude of survey point	78.02671

A sample output is shown below for reference:

NH Number	Section Code	Start Chainage	End Chainage	Direction	Lane Number	Skid Left	Skid Right	Skid Average	Speed	Survey Date	Latitude	Longitude
NH00xx	ABC-DEF	0.0	0.5	Increasing	L1	25.0	24.0	24.5	20	06-05-17	9.98897	78.02671
NH00xx	ABC-DEF	0.5	1.0	Increasing	L1	23.0	23.0	23.0	37	06-05-17	9.98444	78.02934
NH00xx	ABC-DEF	1.0	1.5	Increasing	L1	23.0	24.0	23.5	42	06-05-17	9.98341	78.03004
NH00xx	ABC-DEF	1.5	2.0	Increasing	L1	22.0	22.0	22.0	46	06-05-17	9.98107	78.03078
NH00xx	ABC-DEF	2.0	2.5	Increasing	L1	20.0	21.0	20.5	42	06-05-17	9.96328	78.04160
NH00xx	ABC-DEF	2.5	3.0	Increasing	L1	24.0	24.0	24.0	49	06-05-17	9.95385	78.05255
NH00xx	ABC-DEF	3.0	3.5	Increasing	L1	28.0	28.0	28.0	42	06-05-17	9.93102	78.05648
NH00xx	ABC-DEF	3.5	4.5	Increasing	L1	21.0	21.0	21.0	33	06-05-17	9.91229	78.04961
NH00xx	ABC-DEF	4.5	5.0	Increasing	L1	25.0	24.0	24.5	32	06-05-17	9.89041	78.03458

## 2.6 Falling Weight Deflectometer (FWD)

The following table lists the fields which need to be populated for the 'FWD' attribute. The descriptions of the fields are given below.

Field	Description	Example
NHNumber	New National Highway number	NH0065
SectionCode	Code indicating starting and ending locations of section	HYD-VIJ (Hyderabad-Vijayawada)
Chainage	Chainage of survey point (in km)	0.500
Direction	Direction of survey <ul style="list-style-type: none"> <li>• Increasing (chainage)</li> <li>• Decreasing (chainage)</li> </ul>	Increasing
LaneNumber	Number of the lane: L1, L2, R1, R2, etc., L1 being 1 <sup>st</sup> lane on the left from centreline of carriageway, L2 being 2 <sup>nd</sup> lane on the left from centerline and so on	L1
AirTemperature	Air temperature recorded in °C	33
SurfaceTemperature	Temperature of the pavement surface, recorded in °C	39.3
PeakLoad	Peak impulse load, measured in kN	45.7
Deflection0	Surface deflection at the test load center, measured in micron	246
Deflection1	Surface deflection at location 1 from the test load center, measured in micron	110
Distance1	Distance of location 1 from the test load center	300
Deflection2	Surface deflection at location 2 from the test load center, measured in micron	153
Distance2	Distance of location 2 from the test load center	600
Deflection3	Surface deflection at location 3 from the test load center, measured in micron	110
Distance3	Distance of location 3 from the test load center	900
Deflection4	Surface deflection at location 4 from the test load center, measured in micron	76

Field	Description	Example
Distance4	Distance of location 4 from the test load center	1200
Deflection5	Surface deflection at location 5 from the test load center, measured in micron	59
Distance5	Distance of location 5 from the test load center	1500
Deflection6	Surface deflection at location 6 from the test load center, measured in micron	44
Distance6	Distance of location 6 from the test load center	1800
Deflection7	Surface deflection at location 7 from the test load center, measured in micron	35
Distance7	Distance of location 7 from the test load center	2100
Deflection8	Surface deflection at location 8 from the test load center, measured in micron	28
Distance8	Distance of location 8 from the test load center	2400
ElasticModulusBituminousE1	Elastic modulus of bituminous layer, backcalculated in MPa	3359
ElasticModulusGranularE2	Elastic modulus of granular layer, backcalculated in MPa	396
ElasticModulusSubGradeE3	Elastic modulus of subgrade, backcalculated in MPa	90
CorrectedElasticModulusBituminousE1	Corrected elastic modulus of bituminous layer in MPa	3424
CorrectedElasticModulusGranularE2	Corrected elastic modulus of granular layer in MPa	300
CorrectedElasticModulusSubGradeE3	Corrected elastic modulus of subgrade in MPa	69
BituminousLayer	Thickness of bituminous layer in mm	105
BaseLayer	Thickness of base layer in mm	230
GSBLayer	Thickness of GSB layer in mm	200
Subgrade CBR	CBR of subgrade	0.08
BituminousLayerCoefficientA1	Layer coefficient of the bituminous layer	0.36

Field	Description	Example
BaseLayerCoefficientA2	Layer coefficient of the base layer	0.17
GranularBaseLayerCoefficientA3	Layer coefficient of the GSB layer	0.17
StructuralNumber	Structural number of the pavement	3.86
ModifiedStructuralNumber	Modified structural number including contribution from subgrade	4.85
SurveyDate	Date of survey in the format <DD-MM-YY>	06-05-17
Latitude	Latitude of survey point	9.98897
Longitude	Longitude of survey point	78.02671

A sample output is shown below for reference:

NHNumber	Section Code	Chainage	Direction	LaneNumber	AirTemperature	SurfaceTemperature	PeakLoad	Deflection0	Deflection1	Location 1	Deflection 2
NH00xx	ABC-DEF	0.500	RHS	R2	32.6	43.7	45.7	333	188	300	243
NH00xx	ABC-DEF	1.000	LHS	L1	29.9	32.6	45.4	317	163	300	217
NH00xx	ABC-DEF	1.499	RHS	R1	33.0	39.3	45.7	246	110	300	153
NH00xx	ABC-DEF	2.000	LHS	L2	28.7	32.4	46.0	293	130	300	187
NH00xx	ABC-DEF	2.500	RHS	R2	33.7	45.8	45.3	429	232	300	316
NH00xx	ABC-DEF	3.000	LHS	L1	29.0	33.0	45.7	343	204	300	252
NH00xx	ABC-DEF	3.500	RHS	R1	33.5	45.4	44.5	373	194	300	268
NH00xx	ABC-DEF	4.010	LHS	L2	28.9	33.5	45.0	348	201	300	254
NH00xx	ABC-DEF	4.500	RHS	R2	33.3	40.3	46.0	393	241	300	301

(table continued...)

Location 2	Deflection3	Location 3	Deflection4	Location 4	Deflection5	Location 5	Deflection6	Location 6	Deflection7	Location 7	Deflection8
600	180	900	128	1200	102	1500	75	1800	58	2100	42
600	158	900	104	1200	70	1500	48	1800	38	2100	28
600	110	900	76	1200	59	1500	44	1800	35	2100	28
600	126	900	81	1200	62	1500	44	1800	32	2100	23
600	227	900	152	1200	116	1500	86	1800	71	2100	58
600	196	900	144	1200	117	1500	85	1800	65	2100	48
600	187	900	118	1200	83	1500	47	1800	31	2100	22
600	198	900	135	1200	105	1500	64	1800	42	2100	26
600	231	900	162	1200	123	1500	82	1800	62	2100	46

(table continued...)

Location 8	ElasticModulusBituminousE 1	ElasticModulusGranularE 2	ElasticModulusSubGradeE 3	CorrectedElasticModulusBituminousE 1	CorrectedElasticModulusGranularE 2	CorrectedElasticModulusSubGradeE 3	BituminousLayer	Base Layer	GSB Layer	Sub grade CBR
2400	6213	185	100	6447	135	78	105	230	200	0.08
2400	5356	195	100	5295	143	78	105	230	200	0.08
2400	3359	396	90	3424	300	69	105	230	200	0.08
2400	4830	226	100	4770	169	78	105	230	200	0.08
2400	4570	137	97	4781	93	75	105	230	200	0.08
2400	8454	135	100	8374	91	78	105	230	200	0.08
2400	4394	165	100	4590	117	78	105	230	200	0.08
2400	7817	139	96	7762	95	74	105	230	200	0.08

2400	7666	123	95	7847	81	73	105	230	200	0.08
------	------	-----	----	------	----	----	-----	-----	-----	------

(table continued...)

BituminousLayerCoefficientA1	BaseLayerCoefficientA2	GranularBaseLayerCoefficientA3	StructuralNumber	ModifiedStructuralNumber	SurveyDate	Latitude	Longitude
0.45	0.13	0.13	3.68	4.82	01-07-16	9.98897	78.02671
0.42	0.13	0.13	3.56	4.70	23-06-16	9.98444	78.02934
0.36	0.17	0.17	3.86	4.85	01-07-16	9.98341	78.03004
0.41	0.14	0.14	3.65	4.79	23-06-16	9.98107	78.03078
0.41	0.11	0.11	3.24	4.34	01-07-16	9.96328	78.04160
0.49	0.11	0.11	3.58	4.72	23-06-16	9.95385	78.05255
0.40	0.12	0.12	3.34	4.48	01-07-16	9.93102	78.05648
0.48	0.12	0.12	3.67	4.75	23-06-16	9.91229	78.04961
0.48	0.11	0.11	3.53	4.59	01-07-16	9.89041	78.03458

## 2.7 Falling Weight Deflectometer (FWD) Rigid

The following table lists the fields which need to be populated for the 'FWD Rigid' attribute. The descriptions of the fields are given below.

Field	Description	Example
NHNumber	New National Highway number	NH0065
SectionCode	Code indicating starting and ending locations of section	HYD-VIJ (Hyderabad-Vijayawada)
Chainage	Chainage of the point (in km)	0.500

Field	Description	Example
Direction	Direction of survey <ul style="list-style-type: none"> <li>Increasing (chainage)</li> <li>Decreasing (chainage)</li> </ul>	Increasing
LaneNumber	Number of the lane: L1, L2, R1, R2, etc.	L2
AirTemperature	Air temperature recorded in °C	30.1
SurfaceTemperature	Temperature of the pavement surface, recorded in °C	39.4
PeakLoad	Peak impulse load, measured in kN	103.7
Deflection1	Surface deflection at the test load center, measured in micron	140
Deflection2	Surface deflection at 300 mm from the test load center, measured in micron	121
Deflection3	Surface deflection at 600 mm from the test load center, measured in micron	108
Deflection4	Surface deflection at 900 mm from the test load center, measured in micron	101
ConcreteSlabThickness	Thickness of concrete slab, measured in mm	300
AreaofDeflectionBasin	Area of deflection basin, calculated from measured deflections, in cm <sup>2</sup>	761
RadiusofRelativeStiffness	Radius of relative stiffness, calculated in mm	823
NormalizedDeflection1	Normalized deflection at location 1, in mm	3.1
NormalizedDeflection2	Normalized deflection at location 2, in mm	2.9
NormalizedDeflection3	Normalized deflection at location 3, in mm	2.4
NormalizedDeflection4	Normalized deflection at location 4, in mm	1.9
ModulusofSubgradeReactionk	Modulus of subgrade reaction, measured in MPa/m	131

Field	Description	Example
ElasticModulusofConcreteEc	Elastic modulus of concrete, calculated in MPa	26118
CubeStrengthofConcretefc	Cube strength of concrete, calculated in MPa	27
Flexuralstrengthofconcretefmr	Flexural strength of concrete, calculated in MPa	3.7
DateOfTesting	Date of testing in the format <DD-MM-YY>	06-05-17
Latitude	Latitude of survey point	9.98897
Longitude	Longitude of survey point	78.02671

A sample output is shown below for reference:

NH No	Section Code	Chain-age	Direction	Lane No.	Air Temperature	Surface Temperature	Peak Load	Deflection 1	Deflection 2	Deflection 3	Deflection 4	Concrete Slab Thicknessh
NH00xx	ABC-DEF	0.0	LHS	L2	29.0	34.9	104.1	167	143	130	119	300
NH00xx	ABC-DEF	0.5	RHS	R2	30.5	38.1	104.4	141	130	122	115	300
NH00xx	ABC-DEF	1.0	LHS	L1	30.0	35.6	105.2	147	111	100	91	300
NH00xx	ABC-DEF	1.5	RHS	R1	28.9	38.3	102.4	140	126	116	107	300
NH00xx	ABC-DEF	2.0	LHS	L2	30.1	39.4	103.7	140	121	108	101	300
NH00xx	ABC-DEF	2.5	RHS	R2	29.0	37.5	104.6	150	134	126	117	300
NH00xx	ABC-DEF	3.0	LHS	L1	30.6	38.9	102.7	124	109	104	92	300
NH00xx	ABC-DEF	3.5	RHS	R1	29.3	39.1	105.9	149	136	128	119	300
NH00xx	ABC-DEF	4.5	RHS	R2	30.3	41.0	104.9	138	127	121	114	300

(table continued...)

Area of Deflection Basin	Radius of Relative Stiffness	Normalized Deflection d1	Normalized Deflection d2	Normalized Deflection d3	Normalized Deflection d4	Modulus of Subgrade Reactionk	Elastic Modulus of Concrete Ec	Cube Strength of Concrete fck	Flexural strength of concrete fmr	Date Of Testing	Latitude	Longitude
759	816	3	3	2	2	112	21590	19	3	25-06-16	9.98897	78.02671
821	1214	3	3	3	2	62	58161	135	8	28-06-16	9.98444	78.02934
684	580	3	3	2	1	246	12051	6	2	25-06-16	9.98341	78.03004
Area of Deflection Basin	Radius of Relative Stiffness	Normalized Deflection d1	Normalized Deflection d2	Normalized Deflection d3	Normalized Deflection d4	Modulus of Subgrade Reactionk	Elastic Modulus of Concrete Ec	Cube Strength of Concrete fck	Flexural strength of concrete fmr	Date Of Testing	Latitude	Longitude
796	1014	3	3	3	2	87	39783	63	6	28-06-16	9.98107	78.03078
761	823	3	3	2	2	131	26118	27	4	25-06-16	9.96328	78.04160
800	1040	3	3	3	2	79	39908	64	6	28-06-16	9.95385	78.05255
789	971	3	3	3	2	107	41290	68	6	25-06-16	9.93102	78.05648
814	1150	3	3	3	2	66	50086	100	7	28-06-16	9.91229	78.04961
826	1257	3	3	3	2	59	64082	164	9	28-06-16	9.89041	78.03458

## SECTION 7. DRAFT FORM OF CONTRACT

**Note:** This draft Agreement is a generic document and shall be modified based on particulars of the Project.

## CONTRACT FOR CONSULTANT'S SERVICES

Between

---

(Name of Client)

And

---

(Name of Consultant)

Dated:

**CONTENTS****Page No.****I FORM OF CONTRACT****II GENERAL CONDITIONS OF CONTRACT****1. General Provisions****1.1 Definitions****1.2 Relation between the Parties****1.3 Law Governing Contract****1.4 Language****1.5 Headings****1.6 Notices****1.7 Location****1.8 Authority of Member in Charge****1.9 Authorized Representatives****1.10 Taxes and Duties****2. Commencement, Completion, Modification and Termination of Contract****2.1 Effectiveness of Contract****2.2 Termination of Contract for Failure to Become Effective****2.3 Commencement of Services****2.4 Expiration of Contract****2.5 Entire Agreement****2.6 Modification****2.7 Force Majeure****2.8 Suspension****2.9 Termination****3. Obligation of the Consultants****3.1 General****3.2 Conflict of Interests****3.3 Confidentiality**

- 3.4 Liability of the Consultants
- 3.5 Insurance to be Taken Out by the Consultants
- 3.6 Accounting, Inspection and Auditing
- 3.7 Consultants' Actions Requiring Client's Prior Approval
- 3.8 Reporting Obligations
- 3.9 Documents Prepared by the Consultants to Be the Property of the Client
- 3.10 Equipment and Materials Furnished by the Client
- 4. Consultants' Personnel and Sub-consultants and or Associates
  - 4.1 General
  - 4.2 Description of Personnel
  - 4.3 Approval of Personnel
  - 4.4 Working Hours, Overtime, Leave, etc.
    - Removal and/or Replacement of Personnel
  - 4.6 Resident Project Manager
- 5. Obligations of the Client
  - 5.1 Assistance and Exemptions
  - 5.2 Access to Land
  - 5.3 Change in the Applicable Law
  - 5.4 Services, Facilities and Property of the Client
  - 5.5 Payment
  - 5.6 Counterpart Personnel
- 6. Payments to the Consultants
  - 6.1 Cost Estimates; Ceiling Amount
  - 6.2 Remuneration and Reimbursable Expenditures
  - 6.3 Currency of Payment
  - 6.4 Mode of Billing and Payment
- 7. Fairness and Good Faith
  - 7.1 Good Faith
  - 7.2 Operation of the Contract

## 8. Settlement of Disputes

### 8.1 Amicable Settlement

### 8.2 Dispute Settlement

## III SPECIAL CONDITIONS OF CONTRACT

## IV APPENDICES

Appendix A:Description of the Services

Appendix B:Reporting Requirements

Appendix C: Key Personnel and Sub-consultants

Appendix D: Medical Certificate - Deleted

Appendix E:Hours of Work for Key Personnel

Appendix F:Duties of the Client

Appendix G: Cost Estimates in Foreign Currency - Deleted

Appendix H: Cost Estimates in Local Currency

Appendix I: FORM OF PERFORMANCE SECURITY

Appendix J: Form of Bank Guarantee for Advance Payments

Appendix K:Letter of invitation

Appendix L: Letter of Award

Appendix M: Minutes of pre-bid meeting - Deleted

Appendix N: Memorandum of Understanding between

## I FORM OF CONTRACT

### COMPLEX TIME BASED ASSIGNMENTS

This CONTRACT (hereinafter called the “Contract”) is made the \_\_\_\_ day of the \_\_\_\_\_  
 Month of \_\_\_\_, 200 \_\_\_\_, between, on the one hand \_\_\_\_\_ (hereinafter  
 Called the “Client”) and, on the other hand, \_\_\_\_\_ (hereinafter called  
 the “Consultants”).

*[Note\*: If the Consultants consist of more than one entity, the above should be partially amended to read as follows:*

*“...(hereinafter called the “Client”) and, on the other hand, a joint venture consisting of the following entities, each of which will be jointly severally liable to the Client for all the Consultants’ obligations under this Contract, namely, \_\_\_\_\_ and \_\_\_\_\_ (hereinafter called “Consultants”)]*

#### WHEREAS

- (a) the Client has requested the Consultants to provide certain consulting services as defined in the General Conditions of Contract attached to this Contract (hereinafter called the “Services”);
- (b) the Consultants, having represented to the Client that they have the required professional skills, and personnel and technical resources, have agreed to provide the Services on the terms and conditions set forth in this Contract;

NOW THEREFORE the parties hereto hereby agree as follows:

1. The following documents attached hereto shall be deemed to form an integral part of this Contract:
  - (b) The General Conditions of Contract (hereinafter called “GC”)
  - (c) The Special Conditions of Contract (hereinafter called “SC”);
  - (d) The following Appendices:

[Note: If any of these Appendices are not used, the words “Not Used” should be inserted below next to the title of the Appendix on the sheet attached hereto carrying the title of that Appendix].

<b>Appendix A</b>	<b>:</b>	<b>Description of the Services .....</b>
<b>Appendix B</b>	<b>:</b>	<b>Reporting Requirements .....</b>
<b>Appendix C</b>	<b>:</b>	<b>Key Personnel and Sub-consultants .....</b>
<b>Appendix D</b>	<b>:</b>	<b>Medical Certificate ..... Deleted</b>
<b>Appendix E</b>	<b>:</b>	<b>Hours of Work for Key Personnel .....</b>

- 
- Appendix F : Duties of the Client .....**
- Appendix G : Cost Estimates in Foreign Currency ..... Deleted**
- Appendix H : Cost Estimates in Local Currency .....**
- Appendix I : Form of Performance Bank Guarantee**
- Appendix J : Form of Bank Guarantee for Advance Payments**
- Appendix K : Letter of invitation**
- Appendix L : Letter of Award**
- Appendix-M : Minutes of pre-Bid Meeting - Deleted**
- Appendix-N : Memorandum of Understanding (in case of JV)**
2. The mutual rights and obligations of the Client and the Consultants shall be as set forth in the Contract; in particular
- (a) The Consultants shall carry out the Services in accordance with the provisions of the Contract; and
  - (b) The Client shall make payments to the Consultants in accordance with the Provisions of the Contract.

IN WITNESS WHEREOF, the Parties hereto have caused this Contract to be signed in their respective names as of the day and year first above written.

---

FOR AND ON BEHALF OF [NAME OF THE CLIENT]

By

(Authorized Representative)

---

FOR AND ON BEHALF OF [NAME OF THE CONSULTANTS]

By

(Authorized Representative)

[Note: If the Consultants consist of more than one entity, all of these entities should appear as signatures, e.g. in the following manner]

---

FOR AND ON BEHALF OF EACH OF THE MEMBERS OF THE CONSULTANTS

[Name of the Member]

By

(Authorized Representative)

---

*[Name of the Member]*

By

(Authorized Representative)

etc.

## II GENERAL CONDITIONS OF CONTRACT

### 1. General Provisions

#### 1.1 Definitions

Unless the context otherwise requires, the following terms whenever used in this Contract have the following meanings:

- (a) “Applicable Law” means the laws and any other instruments having the force of law in the Government’s country [or in such other country as may be specified in the Special Conditions of Contract (SC)], as they may be issued and in force from time to time.
- (b) “Contract means the Contract signed by the Parties, to which these General Conditions of Contract are attached, together with all the documents listed in Clause 1 of such signed Contract;
- (c) “Effective Date’ means the date on which this Contract comes into force and effect pursuant to Clause GC 2.1;
- (d) ‘foreign currency’ means any currency other than the currency of the Government;
- (e) ‘GC means these General Conditions of Contract;
- (f) “Government” means the Government of Client’s Country;
- (g) ‘Local currency’ means the Indian Rupees;
- (h) “Consultant” wherever mentioned in this Contract Agreement means the “Supervision Consultant” and includes and sub-consultants or Associates engaged by the primary consultant.
- (i) “Member”, in case the Consultants consist of a joint venture of more than one entity, means any of these entities, and “Members” means all of these entities;
- (j) “Party’ means the Client or the Consultants, as the case may be, and Parties means both of them;
- (k) “Personnel” means persons hired by the Consultants or by any Sub-Consultants and or Associates as Employees and assigned to the performance of the Services or any part thereof; “Foreign Personnel” means such persons who at the time of being so hired had their domicile outside the Government’s Country, “Local Personnel” means such persons who at the time of being so hired had their domicile inside the Government’s Country; and ‘key personnel’ means the personnel referred to in Clause GC 4.2 (a).
- (l) "SC" means the Special Conditions of Contract by which these General Conditions of Contract may be amended or supplemented;
- (m) "Services" means the work to be performed by the Consultants pursuant to his contract, as described in Appendix A hereto. The scope of work will be strictly

as given in various Clauses in TOR. The approach and methodology to be adopted by the Consultant for carrying out the assignment as Supervision Consultant may be modified depending on the site requirements and work programme of the Contractor after mutual discussions with NHAI, the Contractor and the Supervision Consultant. The work plan as indicated by the Consultant may be modified accordingly to the site requirements.

- (n) "Sub-consultant and or Associates " means any entity to which the Consultants subcontract any part of the Services in accordance with the provisions of Clause GC 3.7; and
- (o) "Third Party" means any person or entity other than the Government, the Client, the Consultants or a Sub-consultant.

## 1.2 Relation between the Parties

Nothing contained herein shall be construed as establishing a relation of master and servant or of principal and agent as between the Client and the Consultants. The Consultants, subject to this Contract, have complete charge of Personnel and Sub-consultants, if any, performing the Services and shall be fully responsible for the Services performed by them or on their behalf hereunder.

## 1.3 Law Governing Contract

This Contract, its meaning and interpretation, and the relation between the Parties shall be governed by the Applicable Law.

## 1.4 Language

This Contract has been executed in the language specified in the SC, which shall be the binding and controlling language for all matters relating to the meaning or interpretation of this Contract.

## 1.5 Headings

The headings shall not limit, alter or affect the meaning of this Contract.

## 1.6 Notices

1.6.1 Any notice, request or consent required or permitted to be given or made pursuant to this Contract shall be in writing. Any such notice, request or consent shall be deemed to have been given or made when delivered in person to an authorized representative of the Party to whom the communication is addressed, or when sent by registered mail, telegram or facsimile to such Party at the address specified in the SC.

1.6.2 Notice will be deemed to be effective as specified in the SC.

1.6.3 A Party may change its address for notice hereunder by giving the other Party notice of such change pursuant to the provisions listed in the SC with respect to Clause GC 1.6.2.

## 1.7 Location

The Services shall be performed at such locations as are specified in Appendix A hereto and, where the location of a particular task is not so specified, at such locations. Whether in Government's Country or elsewhere, as the Client may approve.

#### 1.8 Authority of Member in Charge

In case the Consultants consist of a joint venture of more than one entity, the Members hereby authorize the entity specified in the SC to act on their behalf in exercising all the Consultants' rights and obligations towards the Client under this Contract, including without limitation the receiving of instructions and payments from the Client.

#### 1.9 Authorized Representatives

Any action required or permitted to be taken, and any document required or permitted to be executed, under this Contract by the Client or the Consultants may be taken or executed by the officials specified in the SC.

#### 1.10 Taxes and Duties

Unless otherwise specified in the SC, the Consultants, Sub-consultants and Personnel shall pay such taxes, duties, fees and other impositions as may be levied under the Applicable Law. NHAI shall reimburse only Goods and service tax on production of project specific proof of payment of Goods and service tax.

### 2. Commencement, Completion, Modification and Termination of Contract

#### 2.1 Effectiveness of Contract

This Contract shall come into force and effect on the date (the "Effective Date") of the Client's notice to the Consultants instructing the Consultants to begin carrying out the Services. This notice shall confirm that the effectiveness conditions, if any, listed in the SC have been met.

#### 2.2 Termination of Contract for Failure to Become Effective

If this Contract has not become effective within such time period after the date of the Contract signed by the Parties as shall be specified in the SC, either Party may, by not less than four (4) weeks' written notice to the other Party, declare this Contract to be null and void, and in the event of such a declaration by either Party, neither Party shall have any claim against the other Party with respect hereto.

#### 2.3 Commencement of Services

The Consultants shall begin carrying out the Services at the end of such time period after the Effective Date as shall be specified in the SC.

#### 2.4 Expiration of Contract

Unless terminated earlier pursuant to Clause GC 2.9 hereof, this Contract shall expire when services have been completed and all payments have been made at the end of such time period after the Effective Date as shall be specified in the SC.

## 2.5 Entire Agreement

This Contract contains all covenants, stipulations and provisions agreed by the Parties. No agent or representative of either Party has authority to make, and the Parties shall not be bound by or be liable for, any statement, representation, promise or agreement not set forth herein.

## 2.6 Modification

Modification of the terms and conditions of this Contract, including any modification of the scope of the Services, may only be made by written agreement between the Parties as the case may be, has been obtained. Pursuant to Clause GC 7.2 hereof, however, each Party shall give due consideration to any proposals for modification made by the other Party.

## 2.7 Force Majeure

### 2.7.1 Definition

- (a) For the purposes of this Contract, "Force Majeure" means an event which is beyond the reasonable control of a Party, and which makes a Party's performance of its obligations hereunder impossible or so impractical as reasonably to be considered impossible in the circumstances, and includes, but is not limited to, war, riots, civil disorder, earthquake, fire, explosion, storm, flood or other adverse weather conditions, strikes, lockouts or other industrial action ( except where such strikes, lockouts or other industrial action are within the power of the Party invoking Force Majeure to prevent), confiscation or any other action by government agencies.
- (b) Force Majeure shall not include (i) any event which is caused by the negligence or intentional action of a party or such Party's Sub-consultants or agents or employees, nor (ii) any event which a diligent Party could reasonably have been expected to both (A) take into account at the time of the conclusion of this Contract and (B) avoid or overcome in the carrying out of its obligations hereunder.
- (c) Force Majeure shall not include insufficiency of funds or failure to make any payment required hereunder.

### 2.7.2 No Breach of Contract

The failure of a Party to fulfill any of its obligations hereunder shall not be considered to be a breach of, or default under, this Contract insofar as such inability arises from an event of Force Majeure, provided that the Party affected by such an event has taken all reasonable precautions, due care" and reasonable alternative measures, all with the objective of carrying out the terms and conditions of this Contract.

### 2.7.3 Measures to be Taken

- (a) A Party affected by an event of Force Majeure shall take all reasonable measures to remove such Party's inability to fulfill its obligations hereunder with a minimum of delay.
- (b) A Party affected by an event of Force Majeure shall notify the other Party of such event as soon as possible, and in any event not later than fourteen (14) days following the occurrence of such event, providing evidence of the nature and cause of such event, and shall similarly give notice of the restoration of normal conditions as soon as possible.
- (c) The Parties shall take all reasonable measures to minimize the consequences of any event of Force Majeure.

#### **2.7.4 Extension of Time**

Any period within which a Party shall, pursuant to this Contract, complete any action or task, shall be extended for a period equal to the time during which such Party was unable to perform such action as a result of Force Majeure.

#### **2.7.5 Payments**

During the period of their inability to perform the Services as a result of an event of Force Majeure, the Consultants shall be entitled to be reimbursed for additional costs reasonably and necessarily incurred by them during such period for the purposes of the Services and in reactivating the Services after the end of such period.

#### **2.7.6 Consultation**

Not later than thirty (30) days after the Consultants, as the result of an event of Force Majeure, have become unable to perform a material portion of the Services, the Parties shall consult with each other with a view to agreeing on appropriate measures to be taken in the circumstances.

### **2.8 Suspension**

The Client may, by written notice of suspension to the Consultants, suspend all payments to the Consultants hereunder if the Consultants fail to perform any of their obligations under this Contract, including the carrying out of the Services, provided that such notice of suspension (i) shall specify the nature of the failure, and (ii) shall request the Consultants to remedy such failure within a period not exceeding thirty (30) days after receipt by the Consultants of such notice of suspension.

### **2.9 Termination**

#### **2.9.1 By the Client**

The Client may, by not less than thirty (30) days' written notice of termination to the Consultants (except in the event listed in paragraph (f) below, for which there shall be a written notice of not less than sixty (60) days), such notice to be given after the

occurrence of any of the events specified in paragraphs (a) through (h) of this Clause GC 2.9.1, terminate this Contract.

- (a) if the Consultants fail to remedy a failure in the performance of their obligations hereunder, as specified in a notice of suspension pursuant to Clause GC 2.8 hereinabove, within thirty (30) days of receipt of such notice of suspension or within such further period as the Client may have subsequently approved in writing;
- (b) if the Consultants become (or, if the Consultants consist of more than one entity, if any of their Members becomes) insolvent or bankrupt or enter into any agreements with their creditors for relief of debt or take advantage of any law for the benefit of debtors or go into liquidation or receivership whether compulsory or voluntary;
- (c) if the Consultants fail to comply with any final decision reached as a result of arbitration proceedings pursuant to Clause GC 8 hereof;
- (d) if the Consultants submit to the Client a statement which has a material effect on the rights, obligations or interests of the Client and which the Consultants know to be false;
- (e) if, as the result of Force Majeure, the Consultants are unable to perform a material portion of the Services for a period of not less than sixty (60) days; or
- (f) if the Client, in its sole discretion and for any reason whatsoever, decides to terminate this Contract.
- (g) if the consultant, in the judgment of the Client has engaged in corrupt or fraudulent practices in competing for or in executing the Contract. For the purpose of this clause:

"corrupt practice" means the offering, giving, receiving or soliciting of anything of value to influence the action of a public official in the selection process or in contract execution.

"fraudulent practice" means a misrepresentation of facts in order to influence a selection process or the execution of a contract to the detriment of the Borrower, and includes collusive practice among consultants (prior to or after submission of proposals) designed to establish prices at artificial non-competitive levels and to deprive the Borrower of the benefits of free and open competition.

- (h) if Contractor represents to NHAI that the Consultant is not discharging his duties in a fair, efficient and diligent manner and if the dispute remains unresolved, NHAI may terminate this contract.

### **2.9.2 By the Consultants**

The Consultants may, by not less than thirty (30) days' written notice to the Client, such notice to be given after the occurrence of any of the events specified in paragraphs (a) through (d) of this Clause GC 2.9.2, terminate this Contract:

- (a) if the Client fails to pay any money due to the Consultants pursuant to this Contract and not subject to dispute pursuant to Clause 8 hereof within forty-five (45) days after receiving written notice from the Consultants that such payment is overdue;
- (b) if the Client is in material breach of its obligations pursuant to this Contract and has not remedied the same within forty-five (45) days (or such longer period as the Consultants may have subsequently approved in writing) following the receipt by the Client of the Consultants' notice specifying such breach;
- (c) if, as the result of Force Majeure, the Consultants are unable to perform a material portion of the Services for a period of not less than sixty (60) days; or
- (d) if the Client fails to comply with any final decision reached as a result of arbitration pursuant to Clause GC 8 hereof.

### **2.9.3 Cessation of Rights and Obligations**

Upon termination of this Contract pursuant to Clauses GC 2.2 or GC 2.9 hereof, or upon expiration of this Contract pursuant to Clause GC 2.4 hereof, all rights and obligations of the Parties hereunder shall cease, except:

- (i) such rights and obligations as may have accrued on the date of termination or expiration;
- (ii) the obligation of confidentiality set forth in Clause GC 3.3 hereof;
- (iii) the Consultants' obligation to permit inspection, copying and auditing of their accounts and records set forth in Clause GC 3.6 (ii) hereof; and
- (iv) any right which a Party may have under the Applicable Law

### **2.9.4 Cessation of Services**

Upon termination of this Contract by notice of either Party to the other pursuant to Clauses GC 2.9.1 or GC 2.9.2 hereof, the Consultants shall, immediately upon dispatch or receipt of such notice, take all necessary steps to bring the Services to a close in a prompt and orderly manner and shall make every reasonable effort to keep expenditures for this purpose to a minimum. With respect to documents prepared by the Consultants and equipment and materials furnished by the Client, the Consultants shall proceed as provided, respectively, by Clauses GC 3.9 or GC 3.10 hereof.

### **2.9.5 Payment upon Termination**

Upon termination of this Contract pursuant to Clauses GC 2.9.1 or GC 2.9.2 hereof, the Client shall make the following payments to the Consultants (after offsetting against these payments any amount that may be due from the Consultant to the Client}:

- (a) remuneration pursuant to Clause GC 6 hereof for Services satisfactorily performed prior to the effective date of termination;
- (b) reimbursable expenditures pursuant to Clause GC 6 hereof for expenditures actually incurred prior to the effective date of termination; and
- (c) except in the case of termination pursuant to paragraphs (a) through (d) of Clause GC 2.9.1 hereof, reimbursement of any reasonable cost incident to the prompt and orderly termination of the Contract including the cost of the return travel of the Consultants' personnel and their eligible dependents.

### **2.9.6 Disputes about Events of Termination**

If either Party disputes whether an event specified in paragraphs (a) through (e) of Clause GC 2.9.1 or in Clause GC 2.9.2 hereof has occurred, such Party may, within forty-five (45) days after receipt of notice of termination from the other Party, refer the matter to arbitration pursuant to Clause GC 8 hereof, and this Contract shall not be terminated on account of such event except in accordance with the terms of any resulting arbitral award.

## **3. Obligation of the Consultants**

### **3.1 General**

#### **3.1.1 Standard of Performance**

The Consultants shall perform the Services and carry out their obligations hereunder with all due diligence, efficiency and economy, in accordance with generally accepted professional techniques and practices, and shall observe sound management practices, and employ appropriate advanced technology and safe and effective equipment, machinery, materials and methods" The Consultants shall always" act, in respect of any matter relating to this Contract or to the Services, as faithful advisers to the Client, and shall at all times support and safeguard the Client's legitimate interests in any dealings with Sub-consultants or Third Parties.

#### **3.1.2 Law Governing Services**

The Consultants shall perform the Services in accordance with the Applicable Law and shall take all practicable steps to ensure that any Sub- consultants and or Associates, as well as the Personnel of the Consultants and any Sub-consultants and or Associates, comply with the Applicable Law. The Client shall advise the Consultants in writing of relevant local customs and the Consultants shall, after such notifications, respect such customs.

## 3.2 Conflict of Interests

### 3.2.1 Consultants Not to Benefit from Commissions, Discounts, etc.

The Remuneration of the Consultants pursuant to Clause GC 6 hereof shall constitute the Consultants' sole remuneration in connection with this Contract or the Services and, subject to Clause GC 3.2.2 hereof, the Consultants shall not accept for their own benefit any trade commission, discount or similar payment in connection with activities pursuant to this Contract or to the Services or in the discharge of their obligations hereunder, and the Consultants shall use their best efforts to ensure that any Sub-consultants and or Associates, as well as the Personnel and agents of either of them, similarly shall not receive any such additional remuneration.

3.2.2 If the Consultants, as part of the Services, have the responsibility of advising the Client on the procurement of goods, works or services, the Consultants shall comply with any applicable procurement guidelines of the Client (NHAI) and or Associates Bank or of the Association, as the case may be, and other funding agencies and shall at all times exercise such responsibility in the best interest of the Client. Any discounts or commissions obtained by the Consultants in the exercise of such procurement responsibility shall be for the account of the Client.

### 3.2.3 Consultants and Affiliates Not to engage in Certain Activities

The Consultants agree that, during the term of this Contract and after its termination, the Consultants and any entity affiliated with the Consultants, as well as any Sub-consultant and or Associates and any entity affiliated with such Sub-consultant and or Associates, shall be disqualified from providing goods, works or services (other than the Services and any continuation thereof) for any project resulting from or closely related to the Services.

### 3.2.4 Prohibition of Conflicting Activities

The Consultants shall not engage, and shall cause their Personnel as well as their Sub-consultants and or Associates and their Personnel not to engage, either directly or indirectly, in any of the following activities:

- (a) during the term of this Contract, any business or professional activities in the Government's country which would conflict with the activities assigned to them under this Contract; and
- (b) after the termination of this Contract, such other activities as may be specified in the SC.

## 3.3 Confidentiality

The Consultants, their Sub-consultants and the Personnel of either of them shall not, either during the term or within two (2) years after the expiration of this Contract, disclose any proprietary or confidential information relating to the Project, the

Services, this Contract or the Client's business or operations without the prior written consent of the Client.

### 3.4 Liability of the Consultants

Subject to additional provisions, if any, set forth in the SC, the Consultants' liability under this Contract shall be as provided by the Applicable Law.

### 3.5 Insurance to be Taken Out by the Consultants

The Consultants (i) shall take out and maintain, and shall cause any Sub-consultants to take out and maintain, at their ( or the Sub-consultants', as the case may be) own cost but on terms and conditions approved by the Client, insurance against the risks, and for the coverages, as shall be specified in the SC, and (ii) at the Client's request, shall provide evidence to the Client showing that such insurance has been taken out and maintained and that the current premiums therefore have been paid.

### 3.6 Accounting, Inspection and Auditing

The Consultants (i) shall keep accurate and systematic accounts and records in respect of the Services, hereunder, in accordance with internationally accepted accounting principles and in such form and detail as will clearly identify all relevant time charges and cost, and the bases thereof (including such bases as may be specifically referred to in the SC); (ii) shall permit the Client or its designated representative periodically, and up to one year from the expiration or termination of this Contract, to inspect the same and make copies thereof as well as to have them audited by auditors appointed by the Client; and (iii) shall permit the client to inspect the Consultant's accounts and records relating to the performance of the Consultant and to have them audited by auditors appointed by the client.

### 3.7 Consultants' Actions Requiring Client's Prior Approval

The Consultants shall obtain the Client's prior approval in writing before taking any of the following actions:

- (a) appointing such members of the Personnel as are listed in Appendix C ("Consultants' Sub-consultants' Key Personnel") merely by title but not by name;
- (b) entering into a subcontract for the performance of any part of the Services, it being understood (i) that the selection of the Sub-consultant and the terms and conditions of the subcontract shall have been approved in writing by the Client prior to the execution of the subcontract, and (ii) that the Consultants shall remain fully liable for the performance of the Services by the Sub-consultant and its Personnel pursuant to this Contract; and
- (c) any other action that may be specified in the SC

### 3.8 Reporting Obligations

The Consultants shall submit to the Client the reports and documents specified in Appendix B hereto, in the form, in the numbers and within the time periods set forth in the said Appendix.

### 3.9 Documents Prepared by the Consultants to Be the Property of the Client

All plans, drawings, specifications, designs, reports, other documents and software prepared by the Consultants for the Client under this Contract shall become and remain the property of the Client, and the Consultants shall, not later than upon termination or expiration of this Contract, deliver all such documents to the Client, together with a detailed inventory thereof. The Consultants may retain a copy of such documents and software. Restrictions about the future use of these documents and software, if any, shall be specified in the SC.

### 3.10 Equipment and Materials Furnished by the Client

Equipment and materials made available to the Consultants by the Client, or purchased by the Consultants with funds provided by the Client, shall be the property of the Client and shall be marked accordingly. Upon termination or expiration of this Contract, the Consultants shall make available to the Client an inventory of such equipment and materials and shall dispose of such equipment and materials in accordance with the Client's instructions. While in possession of such equipment and materials, the Consultants, unless otherwise instructed by the Client in writing, shall insure them at the expense of the Client in an amount equal to their full replacement value.

## 4. Consultants' Personnel and Sub-consultants and or Associates

### 4.1 General

The Consultants shall employ and provide such qualified and experienced Personnel and Sub-consultants as are required to carry out the Services.

### 4.2 Description of Personnel

- (a) The titles, agreed job descriptions, minimum qualification and estimated periods of engagement in the carrying out of the Services of each of the Consultants' Key Personnel are described in Appendix C. If any of the Key Personnel has already been approved by the clients his/her name is listed as well.
- (b) If required to comply with the provisions of Clause GCC 3.1.1 hereof, adjustments with respect to the estimated periods of engagement of Key Personnel set forth in Appendix C may be made by the Consultants by written notice to the Client, provided (i) that such adjustments shall not alter the originally estimated period of engagement of any individual by more than 10% or one week, whichever is larger, and (ii) that the aggregate of such adjustments shall not cause payments under this Contract to exceed the ceilings set forth in Clause GC 6.1(b) of this Contract. Any other such adjustments shall only be made with the Client's written approval.

- (c) If additional work is required beyond the scope of the Services specified in Appendix A, the estimated periods of engagement of Key Personnel set forth in Appendix C may be increased by agreement in writing between the Client and the Consultants, provided that any such increase shall not, except as otherwise agreed, cause payments under this Contract to exceed the ceilings set forth in Clause GC 6.1 (b) of this Contract.

#### 4.3 Approval of Personnel

The Key Personnel i.e. Professional Staff and Sub-consultants listed by title as well as by name in Appendix C are hereby approved by the Client. In respect of other Key Personnel which the Consultants propose, to use in the carrying out of the Services, the Consultants shall submit to the client for review and approval a copy of their biographical data and (in the case of Key personnel to be used within the country of the Government) a copy of a satisfactory medical certificate in the form attached hereto as Appendix D. If the Client does not object in writing (stating the reasons for the objection) within thirty (30) calendar days from the date of receipt of such biographical data and (if applicable) such certificate, such Key Personnel shall be deemed to have been approved by the Client.

#### 4.4 Working Hours, Overtime, Leave, etc.

- (a) Working hours and holidays for Key Personnel are set forth in Appendix E hereto. To account for travel time, foreign Personnel carrying out Services inside the Government's country shall be deemed to have commenced (or finished) work in respect of the Services such number of days before their arrival in (or after their departure from) the Government's country as is specified in Appendix E hereto.
- (b) The Personnel of all types engaged by Consultant to provide Services on this Contract shall not be entitled to be paid for overtime nor to take paid sick leave or vacation leave **except as specified in Appendix E** hereto, and except as specified in such Appendix, the Consultants' remuneration shall be deemed to cover these items. All leave to be allowed to the Personnel is included in the staff-months of service set for in **Appendix C**. Any taking of leave by Personnel shall be subject to the prior approval by the Client and the Consultants shall ensure that absence for leave purposes will not delay the progress and adequate supervision of the Services.

#### 4.5 Removal and/or Replacement of Personnel

- (a) Except as the Client may otherwise agree, no changes shall be made in the Key Personnel. If, for any reason beyond the reasonable control of the Consultants, it becomes necessary to replace any of the Personnel, the Consultants shall forthwith provide as a replacement a person of equivalent or better qualifications.

- (b) If the Client (i) finds that any of the Personnel has committed serious misconduct or has been charged with having committed a criminal action, or (ii) has reasonable cause to be dissatisfied with the performance of any of the Personnel, then the Consultants shall, at the Client's written request specifying the grounds therefore, forthwith provide as a replacement a person with qualifications and experience acceptable to the Client.
- (c) Any of the Personnel provided as a replacement under Clauses (a) and (b) above, the rate of remuneration applicable to such person as well as any reimbursable expenditures (including expenditures due to the number of eligible dependents) the Consultants may wish to claim as a result of such replacement, shall be subject to the prior written approval by the Client. Except as the Client may otherwise agree, (i) the Consultants shall bear all additional travel and other costs arising out of or incidental to any removal and/or replacement, and (ii) the remuneration to be paid to any of the Key Personnel provided as a replacement shall be 90% of the remuneration which would have been payable to the Key Personnel replaced. However, for the reason other than death/extreme medical ground, (i) for total replacement upto 33% of key personnel, remuneration shall be reduced by 5% (ii) for total replacement upto between 33% to 50%, remuneration shall be reduced by 10% and (iii) for total replacement upto between 50% to 66%, remuneration shall be reduced by 15% (iv) For total replacements beyond 66% of the key personnel the client shall initiate action of higher penalty/termination/debarment upto 2 years as considered appropriate.
- (d) In order to prevent the tendency of the personnel and consulting firm to submit incorrect and inflated CV, they should sign every page of CV before submission in order to authenticate that CV furnished by them is correct. The consulting firm and the personnel through consulting firm should be informed by NHAI while accepting CV of the new personnel that if CV is found in correct and inflated at a later date, the personnel accepted would be removed from his assignment and debarred from further NHAI works for 3 years and the new proposed personnel in place of removed personnel would be paid 15% less salary than the original personnel. 15% reduction in the salary will be imposed as a penalty for submitting the incorrect information. This penalty will be imposed only once. If the same consulting firm submits incorrect information again second time, necessary action will be taken by NHAI to black-list that firm.
- (e) In case of extension of contract, the Consultant can propose one time replacement of each key personnel without attracting any penalty or reduction in remuneration, subject to approval of the authority taking into consideration the progress of work at site. Qualifications of replacements shall be better or equivalent to the original key personnel. Any further replacement will be governed as per contract provisions.

#### 4.6 Resident Project Manager

If required by the SC, the Consultants shall ensure that at all times during the Consultants' performance of the Services in the Government's country a resident project manager, acceptable to the Client, shall take charge of the performance of such Services.

### 5. Obligations of the Client

#### 5.1 Assistance and Exemptions

Unless otherwise specified in the SC, the Client shall use its best efforts to ensure that the Government shall:

- (a) provide the Consultants, Sub-consultants and Personnel with work permits and such other documents as shall be necessary to enable the Consultants, Sub-consultants or Personnel to perform the Services;
- (b) assist for the Personnel and, if appropriate, their eligible dependents to be provided promptly with all necessary entry and exit visas, residence permits, exchange permits and any other documents required for their stay in Government's country;
- (c) facilitate prompt clearance through customs of any property required for the Services and of the personal effects of the Personnel and their - eligible dependents;
- (d) issue to officials, agents and representatives of the Government all such instructions as may be necessary or appropriate for the prompt and effective implementation of the Services;
- (e) assist the Consultants and the Personnel and any Sub-consultants and or Associates employed by the Consultants for the Services from any requirement to register or obtain any permit to practice their profession or to establish themselves either individually or as a corporate entity according to the Applicable Law;
- (f) grant to the Consultants, any Sub-consultants and or Associates and the Personnel of either of them the privilege, pursuant to the Applicable Law, of bringing into Government's country reasonable amounts of foreign currency for the purposes of the Services or for the personal use of the Personnel and their dependents and of withdrawing any such amounts as may be earned therein by the Personnel in the execution of the Services: and
- (g) Provide to the Consultants, Sub-consultants and or Associates and Personnel any such other assistance as may be specified in the SC.

#### 5.2 Access to Land

The Client warrants that the Consultants shall have, free of charge, unimpeded access to all land in the Government's country in respect of which access is required for the performance of the Services. The Client will be responsible for any damage to such land or any property thereon resulting from such access and will indemnify the Consultants and each of the Personnel in respect of liability for any such damage, unless such damage is caused by the default or negligence of the Consultants or any Sub-consultant or the Personnel of either of them.

### 5.3 Change in the Applicable Law

If, after the date of this Contract, there is any change in the Applicable Law with respect to taxes and duties which increases or decreases the cost or reimbursable expenses incurred by the Consultants in performing the Services, then the remuneration and reimbursable expenses otherwise payable to the Consultants under this Contract shall be increased or decreased accordingly by agreement between the Parties hereto, and corresponding adjustments shall be made to the ceiling amounts specified in Clause GC 6.1(b).

### 5.4 Services, Facilities and Property of the Client

The Client shall make available to the Consultants and the Personnel, for the purposes of the services and free of any charge, the services, facilities and property described in Appendix F at the times and in the manner specified in said Appendix F, provided that if such services, facilities and property shall not be made available to the Consultants as and when so specified, the Parties shall agree on (i) any time extension that it may be appropriate to grant to the Consultants for the performance of the Services, (ii) the manner in which the Consultants shall procure any such services, facilities and property from other sources, and (iii) the additional payments, if any, to be made to the Consultants as a result thereof pursuant to Clause GC 6.1(c) hereinafter.

### 5.5 Payment

In consideration of the Services performed by the Consultants under this Contract, the Client shall make to the Consultants such payments and in such manner as is provided by Clause GC 6 of this Contract.

### 5.6 Counterpart Personnel

(a) If so provided in Appendix F hereto, the Client shall make available to the Consultants, as and when provided in such Appendix F, and free of charge, such counterpart personnel to be selected by the Client, with the Consultants' advice, as shall be specified in such **Appendix F**. Counterpart personnel shall work under the exclusive direction of the Consultants. If any member of the counterpart personnel fails to perform adequately any work assigned to him by the Consultants which is consistent with the position occupied by such member, the Consultants may request the replacement of such member, and the Client shall not unreasonably refuse to act upon such request.

- (b) If counterpart personnel are not provided by the Client to the Consultants as and when specified in Appendix F, the Client and the Consultants shall agree on (i) how the affected part of the Services shall be carried out, and (ii) the additional payments, if any, to be made by the Client to the Consultants as a result thereof pursuant to Clause GC 6.1(c) hereof.

## 6. Payments to the Consultants

### 6.1 Cost Estimates; Ceiling Amount

- (a) An estimate of the cost of the Services payable in local currency is set forth in Appendix H.
- (b) Except as may be otherwise agreed under Clause GC 2.6 and subject to Clause GC 6.1(c), payments under this Contract shall not exceed the ceilings in foreign currency and in local currency specified in the SC. The Consultants shall notify the Client as soon as cumulative charges incurred for the Services have reached 80% of either of these ceilings.
- (c) Notwithstanding Clause GC 6.1(b) hereof, if pursuant to clauses GC 5.3, 5.4 or 5.6 hereof, the Parties shall agree that additional payments in local and/or foreign currency, as the case may be, shall be made to the Consultants in order to cover any necessary additional expenditures not envisaged in the cost estimates referred to in Clause GC 6.1(a) above, the ceiling or ceilings, as the case may be, set forth in Clause GC 6.1 (b) above shall be increased by the amount or amounts, as the case may be, of any such additional payments.

### 6.2 Payment mechanism

- (a) Payment of Supervision Consultant shall be based on the monthly reports. Report shall be approved by the Authority only if it includes all the sections prescribed in the format and submitted as per specified timelines. For 2 months per year, report shall be considered to be completed only if detailed equipment based inspection report is attached with the monthly report.
- (b) Payment shall be based on following criteria

Payment dependent on	% of annual contract value per report	Total % of annual contract value
Monthly reports which do not contain equipment based inspection report (For 10 months in a year)	7.5%	75%
Monthly Status reports which contain equipment based inspection report (For 2	12.5%	25%

months in a year)		
-------------------	--	--

Note: Annual contract value shall be calculated as = Total contract value divided by number of years of original contract period

For avoidance of doubt, during 36 months tenure of Consultant, Monthly Reports without equipment based inspection report shall be submitted for 30 months. Submission of these 30 reports will provide 75% of contract value. Actual payment will be in accordance with Payments section in General Conditions of Contract and Special Conditions of Contract. Monthly Status Reports with equipment based inspection report shall be submitted for 6 months. Submissions of these 6 reports will provide 25% of contract value.

- (c) Non availability of key personnel shall attract deduction in monthly payment as per billing rates provided by the Consultant in APPENDIX C-3 : BREAKDOWN OF LOCAL CURRENCY COSTS. In case of replacement of key personnel, deduction in monthly payment shall be done as per Clause GC 4.5.
- (d) It is mandatory to use all the equipment mentioned in Section 6.4 of TOR for road inspection surveys. Non-use of equipment in the survey month as specified in Annexure- IV (Month of survey for equipment based road condition assessment) can be considered only in unavoidable circumstances. However, non-use of equipment shall lead to deduction in monthly payment as per the following table

S No	Equipment to be used	Payment to be released (as % of monthly payment linked to equipment based report)
1	Network Survey Vehicle and laser profile meter (NSV)	50%
3	Falling Weight Reflectometer (FWD)	15%
4	Mobile Bridge Inspection Unit (MBIU)	15%
5	Retro-reflectometer	5%
6	ATCC	15%

S No	Equipment to be used	Payment to be released (as % of monthly payment linked to equipment based report)
	<b>Total</b>	<b>100%</b>

For avoidance of doubt, in case no equipment is used in the survey month, then no monthly payment shall be released. In case, only Network Survey Vehicle is used then 50% of monthly payment (which is 50% of 12.5% of annual contract value) shall be released. Payment linked to equipment based report shall be released only on completion of equipment based road inspection and submission of equipment based report.

- (e) The consultant can use the equipment during next 3 months of survey month. However, 10% penalty per month shall be imposed for delay in use of equipment. Thus, payment linked to the specific equipment shall be released after deducting 10% penalty per month. In case 1 or more equipment is not used during next 3 months of survey month, then this shall be treated as Breach of Contract and performance security shall be liable to be forfeited.
- (f) If any of the report is found to be misleading or containing incorrect information as determined by the Authority, 10% of payment linked to that report shall be deducted as penalty.
- (g) **Payment during Extension of services-** In case of extension of contract, payment shall be governed by the similar criteria as applicable for contract duration i.e. 7.5% for monthly reports which do not include equipment based inspection and 12.5% for monthly reports which include equipment based inspection.

### 6.3 Currency of Payment

- (a) local currency payments shall be made in the currency of the Government.

### 6.4 Mode of Billing and Payment

Billing and payments in respect of the Services shall be made as follows:

- (a) The Client shall cause to be paid to the Consultants an interest bearing advance payment as specified in the SC, and as otherwise set forth below. The advance payment will be due after provision by the Consultants to the Client of a bank guarantee by a bank acceptable to the Client in an amount (or amounts) and in a currency (or currencies) specified in the SC, such bank guarantee (I) to remain effective until the advance payment has been fully set off as provided

in the SC, and (ii) to be in the form set forth in Appendix I hereto or in such other form as the Client shall have approved in writing.

- (b) As soon as practicable and not later than fifteen (15 days) after the end of each calendar month during the period of the Services, the Consultants shall submit to the Client, in duplicate, itemized statements, accompanied by copies of receipted invoices, vouchers and other appropriate supporting materials, of the amounts payable pursuant to Clauses GC 6.3 and 6.4 for such month. Separate monthly statements shall be submitted in respect of amounts payable in foreign currency and in local currency.
- (c) The Client shall cause the payment of the Consultants periodically as given in schedule of payment above within thirty (30) days after the receipt by the Client of bills with supporting documents.
- (d) The final payment under this Clause shall be made only after the final report and a final statement, identified as such, shall have been submitted by the Consultants and approved as satisfactory by the Client. The Services shall be deemed completed and finally accepted by the Client and the final report and final statement shall be deemed approved by the Client as satisfactory ninety (90) calendar days after receipt of the final report and final statement by the Client unless the Client, within such ninety (90)-day period, gives written notice to the Consultants specifying in detail deficiencies in the Services, the final report or final statement. The Consultants shall thereupon promptly make any necessary corrections, and upon completion of such corrections, the foregoing process shall be repeated. Any amount which the Client has paid or caused to be paid in accordance with this Clause in excess of the amounts actually payable in accordance with the provisions of this Contract shall be reimbursed by the Consultants to the Client within thirty, (30) days after receipt by the Consultants of notice thereof. Any such claim by the Client for reimbursement must be made within twelve (12) calendar months after receipt by the Client of a final report and a final statement approved by the Client in accordance with the above.
- (e) All payments under this Contract shall be made to the account of the Consultants specified in the SC.

## 7. Fairness and Good Faith

### 7.1 Good Faith

The Parties undertake to act in good faith with respect to each other's rights under this Contract and to adopt all reasonable measures to ensure the realization of the objectives of this Contract.

### 7.2 Operation of the Contract

The Parties recognize that it is impractical in this Contract to provide for every contingency which may arise during the life of the Contract, and the Parties hereby

agree that it is their intention that this Contract shall operate fairly as between them, and without detriment to the interest of either of them, and that, if during the term of this Contract either Party believes that this Contract is operating unfairly, the Parties will use their best efforts to agree on such action as may be necessary to remove the cause or causes of such unfairness, but no failure to agree on any action pursuant to this Clause shall give rise to a dispute subject to arbitration in accordance with Clause GC 8 hereof.

## **8. Settlement of Disputes**

### **8.1 Amicable Settlement**

The Parties shall use their best efforts to settle amicably all disputes arising out of or in connection with this Contract or the interpretation thereof.

### **8.2 Dispute Settlement**

Any dispute between the Parties as to matters arising pursuant to this Contract which cannot be settled amicably within thirty (30) days after receipt by one Party of the other Party's request for such amicable settlement may be submitted by either Party for settlement in accordance with the provisions specified in the SC.

## **9 Fake CV**

If any case of fake/incorrect/inflated CV is found, it shall be dealt with very severely and would result in all possible penal action including blacklisting from future projects of NHAI. This would also apply even when the consulting firm is not successful in getting the assignment. *In case CV of a person is turned out to be fake/incorrect/inflated during the assignment, the consultancy firms will have to refund the salary and perks drawn including interest @12% per annum in respect of the person apart from other consequences. In addition to above, 10% of the salary and perks to be refunded shall be recovered from the Firm as penalty.*

### III SPECIAL CONDITIONS OF CONTRACT

#### GC Clause

#### A. Amendments of, and Supplements to, Clauses in the General Conditions of Contract

1.1(a) The words “in the Government’s country” are amended to read “in INDIA”

1.4 The language is: English

1.6.1 The addresses are:

Client: National Highways Authority of India  
Plot No.3, Surya Towers, K.K Nagar,  
1<sup>st</sup> East Street, Madurai - 625 020.

Attention: \_\_\_\_\_

Cable address: \_\_\_\_\_

Telex:- \_\_\_\_\_

Fax:- \_\_\_\_\_

Consultants: Attention:

Cable  
address: \_\_\_\_\_

Telex \_\_\_\_\_

Facsimile \_\_\_\_\_

*[Note': Fill in the Blanks]*

1.6.2 Notice will be deemed to be effective as follows:

- (a) in the case of personal delivery or registered mail, on delivery;
- (b) in the case of telexes, 24 hours following confirmed transmission;
- (c) in the case of telegrams, 24 hours following confirmed transmission; and
- (d) in the case of facsimiles, 24 hours following confirmed transmission.

1.8 The Member in Charge is: Member Sh \*\*\*\*\*.

*(Note: If the Consultants consist of a joint venture of more than one entity, the name of the entity whose address is specified in SC 1.6.1 should be inserted here. If the Consultants consist of one entity, this Clause 1.8 should be deleted from the SC)*

1.9 The Authorized Representative are:

For the Client: \_\_\_\_\_

For the Consultants: \_\_\_\_\_

1.10 The Consultants, Sub-consultants and the Personnel shall pay the taxes, duties, fees, levies and other impositions levied under the existing, amended or enacted laws during life of this contract and the client shall perform such duties in regard to the deduction of such tax as may be lawfully imposed.

2.1 The effectiveness conditions are the following:

(i) Approval of the Contract by the client

2.2 The time period shall be four months or such other time period as the parties may agree in writing.

2.3 The time period shall be one month or such other time period as the Parties may agree in writing.

2.4 The time period shall be 36 months

### **3.4 Limitation of the Consultants' Liability towards the Client**

(e) Except in case of gross negligence or willful misconduct on the part of the Consultants or on the part of any person or firm acting on behalf of the Consultants in carrying out the Services, the Consultants, with respect to damage caused by the Consultants to the Client's property, shall not be liable to the Client:

(i) for any indirect or consequential loss or damage; and

(ii) Consultant will maintain at its expenses; Professional Liability Insurance including coverage for errors and omissions caused by Consultant's negligence in the performance of its duties under this agreement, (A) For the amount not exceeding total payments for Professional Fees and Reimbursable Expenditures made or expected to be made to the Consultants hereunder OR (B) the proceeds, the Consultants may be entitled to receive from any insurance maintained by the Consultants to cover such a liability, whichever of (A) or (B) is higher.

(iii) The policy should be issued only from an Insurance Company operating in India.

- (iv) The policy must clearly indicate the limit of indemnity in terms of “Any One Accident” (AOA) and “Aggregate limit on the policy period” (AOP) and in no case should be for an amount less than stated in the contract.
- (v) If the Consultant enters into an agreement with NHAI in a joint venture or ‘in association’, the policy must be procured and provided to NHAI by the joint venture/in association entity and not by the individual partners of the joint venture/association.
- (vi) The contract may include a provision whereby the Consultant does not cancel the policy midterm without the consent of NHAI. The insurance company may provide an undertaking in this regard.
- (f) This limitation of liability shall not affect the Consultants' liability, if any, for damage to Third Parties caused by the Consultants or any person or firm acting on behalf of the Consultants in carrying out the Services.
- (g) Professional Liability Insurance may be accepted for initially one year which shall be extended annually for five years. PLI shall be uniformly taken for a period of five years.

### 3.5 The risks and the coverage shall be as follows

- (h) Third Party motor vehicle liability insurance as required under Motor Vehicles Act, 1988 in respect of motor vehicles operated in India by the Consultants or their Personnel or any Sub-consultants or their Personnel for the period of consultancy.
- (i) Third Party liability insurance with a minimum coverage, of Rs.1.0 million for the period of consultancy.
- (j) Professional liability insurance as per 3.4 (a) (ii) of SC of the consultancy, with a minimum coverage equal to estimated remuneration and reimbursable.
- (k) Employer's liability and workers' compensation insurance in respect of the Personnel of the Consultants and of any Sub-consultant, in accordance with the relevant provisions of the Applicable Law, as well as, with respect to such Personnel, any such life, health, accident, travel or other insurance as may be appropriate; and
- (l) Insurance against loss of or damage to (i) equipment purchased in whole or in part with funds provided under this Contract, (ii) the Consultants' property used in the performance of the Services, and (iii) any documents prepared by the Consultants in the performance of the Services.

### 3.7(c) The other actions are

- "(i) taking any action under a civil works contract designating the Consultants as "Engineer", for which action, pursuant to such civil works contract, the written approval of the Client as "Employer" is required".

3.9 The Consultants shall not use these documents for purposes unrelated to this Contract without the prior written approval of the Client.

4.6 "The person designated as Team Leader cum Sr. Highway Engineer in Appendix C shall serve in that capacity, as specified in Clause GC 4.6."

6.1(b) The amount payable in foreign currency or currencies is: \_\_\_\_\_

The ceiling in local currency is: \_\_\_\_\_

6.2(a) "Payments made in accordance with Clause GC 6:2(a) in local currency shall be adjusted as follows:

- (i) Annual contract value shall be adjusted every twelve (12) months (and, the first time, applicable for the Annual contract value to be computed in the 13th calendar month after the date of the contract) by 5% per annum. Thus, Annual contract value in second year shall be 105% of Annual contract value in first year, so on and so forth.

Notwithstanding any other provisions in the agreement in this regard, this provision will prevail and over ride any other provision to the contrary in this agreement.

6.4(a) The following provisions shall apply to the interest bearing advance payment and the advance payment guarantee:

- 1) An advance payment. of 10% of the contract price in proportion to the quoted Indian currency (INR) & foreign currency (US dollar) in the bid shall be made within 60 days after receipt and verification of advance payment bank guarantee. The advance payment will be set off by the Client in equal instalments against the statements for the first 12 months of the Service until the advance payment has been fully set off.
- 1) The bank guarantee shall be in the amount and in the currency of the foreign and local currency portion of the advance payment.
- 2) Interest rate shall be 10% per annum (on outstanding amount) for local currency including converted foreign component into local currency.

6.4(c) The interest rate is 6% per annum for local currency.

6.4(e) The accounts are:

For foreign  
currency:

\_\_\_\_\_

For local currency:

\_\_\_\_\_

[Note: Insert account number, type of account and name and address of the Bank]

8.2 Disputes shall be settled by arbitration in accordance with the following provisions:

### 8.2.1 Selection of Arbitrators

Each dispute submitted by a Party to Arbitration shall be heard by a sole arbitrator. NHAI shall within 30 days propose names of five (5) Arbitrators from the list of Arbitrators maintained by SAROD (Society for Affordable Redressal of Disputes) and Consultant shall within 30 days select one name from the list of five and the name so selected by the Consultant shall be the Sole Arbitrator for the matter in dispute. In case NHAI delays in providing the list of 5 names, President, SAROD will provide 5 names within 30 days of receipt of reference from aggrieved party in this regard. In case the Consultant fails in selecting one from the list of five, President, SAROD shall select one from the list of five provided by NHAI within 30 days of receipt of reference from aggrieved party in this regard.

### 8.2.2 Rules of Procedure

Arbitration proceedings shall be conducted in accordance with the procedures of the Arbitration and Conciliation (Amendment) Act, 2015 of India unless the Consultant is a foreign national/ firm, where arbitration proceedings shall be conducted in accordance with the rules of procedure of arbitration of the United Nations Commission on International Trade Law (UNCITRAL) as in force on the date of this Contract.

### 8.2.3 Substitute Arbitrators

If for any reason an arbitrator is unable to perform his function, a substitute shall be appointed in the same manner as the original arbitrator.

### 8.2.4 Qualifications of Arbitrators

The list of five and the sole arbitrator selected pursuant to Clause 8.2.1 hereof shall be expert(s) with extensive experience in relation to the matter in dispute.

### 8.2.5 Miscellaneous

In any arbitration proceeding hereunder:

- (a) Proceedings shall, unless otherwise agreed by the parties be held in Delhi.
- (b) The English language shall be the official language for all purposes;
- (c) The decision of sole arbitrator shall be final and binding and shall be enforceable in any court of competent jurisdiction, and the Parties hereby waive any objections to or claims of immunity in respect of such enforcement; and
- (d) Fee structure shall be as given below:

S. No.	Particulars of fee and other charges	Schedule Amount payable per Arbitrator / per case
1.	Arbitrator fee	Rs.25,000/- per day Or Rs.7 lakhs (lump-sum) subject to publishing the Award within 6 months. Or Rs.5 lakhs (lump-sum) subject to publishing the Award after 6 months but before 12 months. Note:- The amount of fees already paid for the days of hearing @ Rs.25,000/- would be adjusted in the lump- sum payment.
2.	Reading Charges	Rs.25,000/- per Arbitrator per case including counter claim.
3.	Secretarial Assistance and Incidental Charges (telephone, fax, postage etc.)	Rs.20,000/-
4.	Charges for Publishing / declaration of the Award	Rs.35,000/-
5.	Other expenses (As per actuals against bills subject to maximum of the prescribed ceiling given below)	
	Traveling Expenses Lodging and Boarding	Economy class (by air), First class AC (by train) and AC car (by road) (a) Rs.15,000/- per day (Metro cities) (b) Rs.7,000/- per day (in other cities) (c) Rs.3,000/- per day, if any Arbitrator makes own arrangement.
6.	Local Travel	Rs.1,500/- per day
7.	Extra charges for days other than hearing / meeting days (maximum for 2 days)	Rs.5,000/- per day for outstation Arbitrator
Note:	<p>1. Lodging, boarding and travelling expenses shall be allowed only for those members who are residing 100 kms. away from place of meeting.</p> <p>2. Delhi, Mumbai, Chennai, Kolkata, Bangalore and Hyderabad shall be considered as Metro Cities.</p>	



## IV APPENDICES

### Appendix A: Description of the Services

*[Give detailed descriptions of the Services to be provided; dates for completion of various tasks, place of performance for different tasks; specific tasks to be approved by Client, etc.]*

#### Details as per TOR

### Appendix B: Reporting Requirements

*[List format, frequency, contents of reports and number of copies; persons to receive them; dates of submission, etc. If no reports are to be submitted, state here "Not applicable".]*

#### Please refer TOR

### Appendix C: Key Personnel and Sub-consultants

*[List under: C-1Titles [and names, if already available}, detailed job descriptions and minimum qualifications. experience of Personnel to be assigned to work in India, and staff-months for each.*

*C-2 Same information as C-1 for Key local Personnel.*

*C-3 Same as C-1 for Key foreign Personnel to be assigned to work outside India.*

*C-4 List of approved Sub-consultants [if already available]; same information with respect to their Personnel as in C-1 through C-4)*

### Appendix D: Medical Certificate

*Deleted*

### Appendix E: Hours of Work for Key Personnel

The Consultants Key personnel and all other Professional / Sub Professional / Support Staff / Sub-Consultancy personnel shall work 6 days (Mondays through Saturday) every week and observe the Gazetted Holidays of Government of India as Holidays. The Consultant shall work as per the work program of the contractor. In this context incase the work plan of the Consultant needs suitable modifications, the same shall be carried out and submitted to the client for consideration. The Consultants hours of work normally shall match with that of Contractor's activities on the site. No extra remuneration shall be claimed or paid for extra hours of work required in the interest of Project completion.

In respect of foreign personnel, one day per trip as travel time from and to the country of the Government shall be allowed.

**Please refer TOR**

**Appendix F: Duties of the Client**

- (a) Access to the quality control laboratory for performing various types of tests, which will be provided by the Contractor including the testing personnel.
- (b) RFQ, RFP, Contract Agreement, Bid submission, Site Data and information for field surveys and investigations
- (c) Detailed Work plan and Programme for Operation and Maintenance of Project Highway from Contractor.
- (d) Quality Assurance Plan and Quality Control Procedures from the Contractor.
- (e) All the reports and necessary data as per the reporting obligation of Contractor under the Contract Agreement.
- (f) Necessary letters, which will be required for Visa's of foreign personnel and procuring other services by the consultant for performing project services.

**Please refer TOR**

**Appendix G: Cost Estimates in Foreign Currency**

*Deleted*

**Appendix H: Cost Estimates in Local Currency**

*List hereunder cost estimate in local currency:*

1. Monthly rates for local Personnel (Key Personnel and other Personnel)
2. *Reimbursable / Rental / Fixed expenditures as follows:*
  - (a) *Per diem rates for subsistence allowance for foreign short-term Personnel plus estimated totals.*
  - (b) *Living allowances for long-term foreign Personnel, plus estimated totals.*
  - (c) *Cost of local transportation.*
  - (d) *Cost of other local services, rentals, utilities, etc.*

## Appendix I: FORM OF PERFORMANCE SECURITY

### (PERFORMANCE BANK GUARANTEE)

(Clause-20 of TOR)

To

General Manager (Tech) & Regional Officer,  
National Highways Authority of India  
Plot No. 3, Surya Towers,  
2<sup>nd</sup> Floor, 1<sup>st</sup> East Street,  
K.K Nagar,  
Madurai - 625 020.  
Tamil Nadu.

WHEREAS \_\_\_\_\_ [Name and address of Consultants]<sup>1</sup> (hereinafter called “the consultants”) has undertaken in pursuance of Contract No. \_\_\_\_\_ dated \_\_\_\_\_ to provide the services on terms and conditions set forth in this Contract \_\_\_\_\_ [Name of contract and brief description of works) (hereinafter called the “the Contract”).

AND WHEREAS it has been stipulated by you in the said Contract that the Consultants shall furnish you with a Bank Guarantee by a recognized bank for the sum specified therein as security for compliance with his obligations in accordance with the Contract;

AND WHEREAS we have agreed to give the Consultants such a Bank Guarantee;

NOW THEREOF we hereby affirm that we are the Guarantor and responsible to you, on behalf of the Consultants up to a total of \_\_\_\_\_ [amount of Guarantee]<sup>2</sup> \_\_\_\_\_ [in words], such sum being payable in the types and proportions of currencies in which the Contract Price is payable, and we undertake to pay you, upon your first written demand and without cavil or argument, any sum or sums within the limits of [amount of Guarantee] as aforesaid without your needing to prove or to show grounds or reasons for your demand for the sum specified therein.

We hereby waive the necessity of your demanding the said debt from the Consultants before presenting us with the demand.

We further agree that no change or addition to or other modification of the terms of the Contract or of the services to be performed there under or of any of the Contract documents which may be made between you and the Consultants shall in any way release us from any liability under this guarantee, and we hereby waive notice of any such change, addition or modification.

The liability of the Bank under this Guarantee shall not be affected by any change in the constitution of the consultants or of the Bank.

14. " This guarantee shall also be operatable at our \_\_\_\_\_ Branch at New Delhi, from whom, confirmation regarding the issue of this guarantee or extension / renewal thereof shall be made available on demand. In the contingency of this guarantee being invoked and payment there under claimed, the said branch shall accept such invocation letter and make payment of amounts so demanded under the said invocation."

Notwithstanding anything contained herein before, our liability under this guarantee is restricted to Rs. \_\_\_\_\_ (Rs. \_\_\_\_\_) and the guarantee shall remain valid till \_\_\_\_\_. Unless a claim or a demand in writing is made upon us on or before \_\_\_\_\_ all our liability under this guarantee shall cease.

This guarantee shall be valid for a period of 38 months i.e. upto 2 months beyond the expiry of contract of 36 months.

Signature and Seal of the Guarantor \_\_\_\_\_

In presence of

Name and Designation \_\_\_\_\_ 1.

(Name, Signature & Occupation)

Name of the Bank \_\_\_\_\_

Address \_\_\_\_\_ 2.

(Name & Occupation) Date

1. Give names of all partners if the Consultants is a Joint Venture.

## Appendix J: Form of Bank Guarantee for Advance Payments

### (Reference Clause 6.4 (a) of Contract)

(To be stamped in accordance with Stamp Act, if any, of the country of issuing bank)

Ref: \_\_\_\_\_

Bank Guarantee: \_\_\_\_\_

Date: \_\_\_\_\_

Dear Sir,

*In consideration of M/s. \_\_\_\_\_ (hereinafter referred as the "Client", which expression shall, unless repugnant to the context or meaning thereof include its successors, administrators and assigns) having awarded to M/s. \_\_\_\_\_ (hereinafter referred to as the "Consultant" which expression shall unless repugnant to the context or meaning thereof, include its successors, administrators, executors and assigns), a contract by issue of client's Contract Agreement No. \_\_\_\_\_ dated \_\_\_\_\_ and the same having been unequivocally accepted by the Consultant, resulting in a Contract valued at \_\_\_\_\_ for \_\_\_\_\_ Contract (hereinafter called the "Contract")*

(scope of work)

*and the Client having agreed to make an advance payment to the Consultant for performance of the above Contract amounting to (in words and figures) as an advance against Bank Guarantee to be furnished by the Consultant.*

We \_\_\_\_\_

*(Name of the Bank) having its Head Office at \_\_\_\_\_ (hereinafter referred to as the Bank), which expression shall, unless repugnant to the context or meaning thereof, include its successors, administrators executors and assigns) do hereby guarantee and undertake to pay the client immediately on demand any or, all monies payable by the Consultant to the extent of \_\_\_\_\_ as aforesaid at any time up to \_\_\_\_\_ @ \_\_\_\_\_ without any demur, reservation, contest, recourse or protest and/or without any reference to the consultant. Any such demand made by the client on the Bank shall be conclusive and binding notwithstanding any difference between the Client and the Consultant or any dispute pending before any Court, Tribunal, Arbitrator or any other authority. we agree that the Guarantee herein contained shall be irrevocable and shall continue to be enforceable till the Client discharges this guarantee.*

*The Client shall have the fullest liberty without affecting in any way the liability of the Bank under this Guarantee, from time to time to vary the advance or to extend the time for performance of the contract by the Consultant. The Client shall have the fullest liberty without affecting this guarantee, to postpone from time to time the exercise of any powers vested in them or of any right which they might have against the Client and to exercise the same at any time in any manner, and either to enforce or to forebear to enforce any*

*covenants, contained or implied, in the Contract between the Client and the Consultant any other course or remedy or security available to the Client. The bank shall not be relieved of its obligations under these presents by any exercise by the Client of its liberty with reference to the matters aforesaid or any of them or by reason of any other act or forbearance or other acts of omission or commission on the part of the Client or any other indulgence shown by the Client or by any other matter or thing whatsoever which under law would but for this provision have the effect of relieving the Bank.*

*The Bank also agrees that the Client at its option shall be entitled to enforce this Guarantee against the Bank as a principal debtor, in the first instance without proceeding against the Consultant and notwithstanding any security or other guarantee that the Client may have in relation to the Consultant's liabilities.*

*Notwithstanding anything contained herein above our liability under this guarantee is limited to \_\_\_\_\_ and it shall remain in force upto and including \_\_\_\_\_ and shall be extended from time to time for such period (not exceeding one year), as may be desired by M/s. \_\_\_\_\_ on whose behalf this guarantee has been given.*

Dated this \_\_\_\_\_ day of \_\_\_\_\_ 200 \_\_\_\_\_ at

**WITNESS**

\_\_\_\_\_ (signature)

(Signature)

\_\_\_\_\_

(Name)

(Name)

\_\_\_\_\_

\_\_\_\_\_

\_\_\_\_\_

\_\_\_\_\_

(Official Address) Designation (with Bank stamp) Attorney as per Power of

Attorney No. \_\_\_\_\_

Dated

\_\_\_\_\_

Strike out, whichever is not applicable.

*Note 1: The stamp papers of appropriate value shall be purchased in the name of bank who issues the "Bank Guarantee".*

*Note 2: The bank guarantee shall be from a Nationalized Indian Bank or reputed foreign commercial Bank acceptable to client for Foreign Consultant with counter guarantee from Nationalized Bank. Bank guarantee furnished by Foreign consultant shall be confirmed by any Nationalized Bank in India.*

**Appendix K: Letter of invitation**

**Appendix L: Letter of Award**

**Appendix M: Minutes of pre-bid meeting**

## Appendix N: Memorandum of Understanding between

\_\_\_\_\_  
**And**  
 \_\_\_\_\_

Whereas National Highways Authority of India (hereinafter called NHAI) has invited proposal for appointment of Supervision Consultant for (Name of project) hereinafter called the Project.

And Whereas \_\_\_\_\_ (Lead Partner) and \_\_\_\_\_ JV partner/s have agreed to form a Joint Venture to provide the said services to NHAI as Supervision Consultant; and

Now, therefore, it is hereby agreed by and on behalf of the partners as follows:

- (i) \_\_\_\_\_ will be the lead partner and \_\_\_\_\_ will be the other JV partner/s.
- (ii) \_\_\_\_\_ (Lead partner) shall be the incharge of overall administration of contract and shall be authorised representative of all JV partners for conducting all business for and on behalf of the JV during the bidding process and subsequently, represent the joint venture for and on behalf of the JV for all contractual matters for dealing with the NHAI/Contractor if Consultancy work is awarded to JV.
- (iii) All JV partners do hereby undertake to be jointly and severely responsible for all the obligation and liabilities relating to the consultancy work and in accordance with the Terms of Reference of the Request for Proposal for the Consultancy Services.
- (iv) Subsequently, if the JV is selected to provide the desired consultancy services, a detailed MOU indicating the specific project inputs and role of each partner/s along with percentage sharing of cost of services shall be submitted to NHAI (Consultant may submit the detailed MOU along with percentage sharing of cost at the time of bidding also).

For \_\_\_\_\_ (Name of Lead partner)

\_\_\_\_\_  
 Managing Director/Head of the Firm  
 Address

For \_\_\_\_\_ (Name of JV partner/s)

\_\_\_\_\_  
 Managing Director/Head of the Firm

Address

## PROCEDURE UNDER E-TENDERING INSTRUCTIONS TO APPLICANTS

(Note: RFP stands modified to the extent required as per these instructions).

### DEFINITIONS

**NHAI e-Procurement Portal:** An e-tendering portal of National Highways Authority of India (“NHAI”) introduced for the process of e-tendering which can be accessed on <https://etenders.gov.in>

Words in capital and not defined in this document shall have the same meaning as in the Request for Qualification (“RFP”).

### 1. ACCESSING/PURCHASING OF BID DOCUMENTS:

- (i) It is mandatory for all the Applicants to have Class-III digital signature certificate (with both Signing and Encryption certificate)(in the name of person who will sign the Application) from any of the licensed certifying agency (“CA”) [Applicants can see the list of licensed CAs from the link [www.cca.gov.in](http://www.cca.gov.in)] to participate in e-tendering of NHAI. The authorized signatory holding Power of Attorney shall only be the Digital signatory. In case authorized signatory holding Power of Attorney and Digital Signatory are not the same, the bid shall be considered non-responsive
- (ii) **RFP can be viewed/downloaded, free of cost w.e.f 13.01.2018 till 08.02.2018 up to 10.00 hours.**

Following may be noted:

- (a) Applications can be submitted only during the validity of registration with the <https://etenders.gov.in>.
- (b) The amendments/clarifications to the RFP, if any, will be posted on the NHAI website.
- (iii) To participate in bidding, Applicants have to pay a sum of **Rs. 5,000/-** (Rs. Five thousand only) as a cost of the RFP (non-refundable) to “**National Highways Authority of India**” through demand draft payable at Madurai.
- (iv) If the Applicant has already registered with the <https://etenders.gov.in> and validity of registration has not expired, then such Applicant does not require fresh registration.

### 2. PREPARATION AND SUBMISSION OF APPLICATIONS:

- (i) Detailed RFP may be downloaded from <https://etenders.gov.in> and the Bid may be submitted online following the instructions appearing on the screen. A Vendor manual

containing the detailed guidelines for e-tendering system is also available on <https://etenders.gov.in>.

- (ii) The following shall be the form of various documents in the Application:
- A. **Only Electronic Form (to be uploaded on the <https://etenders.gov.in>) [Refer to Clause 4.1 (preparation and submission of Application) of the RFP]**
  - (b) Technical proposal as indicated in para 'B' below
  - (c) Financial proposal as per format prescribed in SECTION-5 OF RFP.
  - B. **Original (in Envelope) [Refer to Clause 4.1 (preparation and submission of Application) of the RFP]**

**(I) Technical Proposal in Hard Bound for including:**

- (a) Power of Attorney for signing the Application
  - (b) If applicable, the Power of Attorney for Lead Member of JV;
  - (c) Copy of Memorandum of Understanding between JV partners, if applicable;
  - (d) Copy of Memorandum of Understanding with Associate if applicable
  - (e) Firms credentials as per format prescribed in SECTION-3 OF RFP.
  - (f) Technical proposal as per format as prescribed in SECTION-4 OF RFP.
- (II) Demand Draft (DD) of Rs.5,000/- (Rupees Five Thousand only) towards the cost of RFP in favor of National Highways Authority of India.
- (III) Duly executed on plain paper 'Integrity Pact' as per enclosed.
- (iii) The Applicant shall submit the original documents specified above in point no.2 (ii) B together with their respective enclosures and seal it in an envelope and mark the envelope as "Technical Proposal" for the Project for which proposal is submitted and name and address of the Applicant. The envelope must be clearly marked "**DO NOT OPEN, EXCEPT IN THE PRESENCE OF THE EVALUATION COMMITTEE**". In addition, the Application due date should be indicated on the right hand corner of the envelope. The original documents should be submitted before **12.00** hours Indian Standard Time on the Application due date i.e. on **09.02.2018**, at the below mentioned address in the manner and form as detailed in the RFP. A receipt thereof should be obtained from the below mentioned person.

ATTN.OF: Shri. GALI SREEDHAR

DESIGNATION General Manager (T) & Regional Officer

ADDRESS National Highways Authority of India,

Plot No. 3, Surya Towers,  
2<sup>nd</sup> Floor, 1<sup>st</sup> East Street,  
K.K Nagar,  
Madurai - 625 020.  
Tamil Nadu.

- (iv) The Applicant shall upload scanned copies of the documents as specified in point nos. 2 (ii) (A) & (B) above on the <https://etenders.gov.in> before 12:00 hours Indian Standard Time on the Application due date. No hard copy of the documents as specified in point nos. 2 (ii) (A) above is required to be submitted. In the event of any discrepancy between the original and the copy (in electronic form), the original shall prevail.
- (v) It may be noted that the scanned copies can be prepared in file format i.e. PDF and/or ZIP only. The Applicants can upload a single file of size of 10 MB only but can upload multiple files.

### **3. MODIFICATION / SUBSTITUTION / WITHDRAWAL OF BIDS:**

- (i) The Bidder may modify, substitute or withdraw its e- bid after submission. Prior to the Bid Due Date. No Bid shall be modified, substituted or withdrawn by the Bidder on or after the Bid Due Date.
- (ii) Any alteration/modification in the Bid or additional information supplied subsequent to the Bid Due Date, unless the same has been expressly sought for by the Authority, shall be disregarded.
- (iii) For modification of e-bid, bidder has to detach its old bid from e-tendering portal and upload/resubmit digitally signed modified bid.
- (iv) For withdrawal of bid, bidder has to click on withdrawal icon at e-tendering portal and can withdraw its e-bid.
- (v) Before withdrawal of a bid, it may specifically be noted that after withdrawal of a bid for any reason, bidder cannot re-submit e-bid again.

### **4. OPENING AND EVALUATION OF APPLICATIONS:**

- (i) Opening of Proposals will be done through online for Financial Proposal and both on-line and manually for Technical Proposal.
- (ii) For participating in the tender, the authorized signatory holding Power of Attorney shall be the Digital Signatory. In case the authorized signatory holding Power of Attorney and Digital Signatory are not the same, the bid shall be considered non-responsive. The Authority shall open Envelope containing Technical Proposal received as mentioned in point nos. 2 (ii) B at 15.00 hours Indian Standard Time on the Application due date i.e. **09.02.2018** in the presence of the Applicants who choose to attend. This Authority will subsequently open the Technical Proposal as mentioned in

point no.2 (ii) A (a) above and evaluate the Applications in accordance with the provisions set out in the RFP.

- (iii) The Financial Proposal 2 (ii) A (b) will be opened of the short listed applicants who qualify for financial opening as per RFP. The date of opening of Financial Proposal will be notified later on.

**DISCLAIMER**

The Applicant must read all the instructions in the RFP and submit the same accordingly.

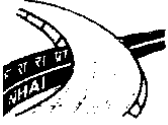

भारतीय राष्ट्रीय राजमार्ग प्राधिकरण  
(सड़क परिवहन और राजमार्ग मंत्रालय)  
**National Highways Authority of India**  
(Ministry of Road Transport and Highways)

जी-5 एवं 6, सेक्टर-10, द्वारका, नई दिल्ली-110075  
G-5 & 6, Sector-10, Dwarka, New Delhi-110075

दूरभाष / Phone : 91-11-25074100/25074200  
फैक्स / Fax : 91-11-25093507 / 25093514

No.13030/09/2008-vig.

Office Memorandum

Dated : 28<sup>th</sup> January, 2013

**Sub: Adoption of Integrity Pact (IP) for NHAI Projects-reg.**

In suppression of OM No. NHAI/CMC/IP/IEM/2011-12 dated 13.08.2012 and OM of NHAI/CMC/IP/IEM/2011-12 dated 14.08.2012, it has been decided to implement the concept of 'Integrity Pact' in NHAI projects. The Integrity Pact (IP) envisages an agreement between the prospective bidders and the buyers committing the persons/officials of both the parties, not to exercise any corrupt influence on any aspect of the contract. The IP also envisages empanelment of Independent External Monitors (IEM). The IEM may review independently and objectively whether and to what extent parties have complied with their obligations under the pact.

2. NHAI is going to appoint IEM shortly for implementation of the IP in NHAI. MoRT&H vide its letter no. C-13019/8/2009-Vig. dated 18.11.2011 has approved applicability of adoption of IP in NHAI works as mentioned below:

- (i) Civil Works above Rs.100.00 crore
- (ii) Services such as consultancy, engineering etc. above Rs.5.00 crore

3. In this connection, all the officers of NHAI are hereby requested to implement and follow the concept of IP and adopt the same in all future projects of NHAI as scrupulously in works included in para.2 above as per Model Agreements (copy enclosed) for each category. This Model Agreement would be provided to the bidders at NIT/ Pre-bid /Technical bid stage, whichever applicable, with instruction to submit the same after signing it. Contractor/ concessionaire / consultant / bidder would be required to submit this duly signed agreement (signed by the same signatory competent/authorized to sign the relevant contract agreement) along with their Technical Bid/Tender Documents. The representative authorized to sign contract agreement, on behalf of NHAI, would sign the same while signing the contract so that this may be made a part of the contract document and binding for both the parties signing the contract.

4. It is clarified that IP should cover all phases of the contract, i.e. from the stage of Notice Inviting Tender (NIT) / pre-bid stage till the conclusion of the contract, i.e. the final payment or the duration of warranty / guarantee / defect liability / concession period, whichever applicable. The IEM would be, invariably, cited in the NIT. Further, information relating to tender in progress and under finalization would need to be shared with IEM on monthly basis.

..2..

5. After implementation of Integrity Pact, NHAI has to send progress/status in the implementation of IP enabling CVC to include the same in their annual report as prescribed in the CVC circular no. 10/5/09 dated 18.05.2009 and subsequent circular no.31/08/10 dated 13.08.2010 (copies enclosed). Further, an internal assessment of the impact of IP shall be carried out periodically by the CVO and reported to the CVC through their report or special report, wherever necessary. In view of this, status of implementation of IP would be reported by all divisions to CVO on monthly basis.
6. All the Divisions engaged in purchase/procurement shall ensure strict compliance of this.

This issues with the approval of Chairman, NHAI.

- Encl: (1) Model Agreement for category (i) works  
(2) Model Agreement for category (ii) works  
(3) CVC's Circular no. 10/5/09 dt. 18.05.09  
(4) CVC's Circular no.31/08/10 dt.13.08.10

To

1. All PIUs/CMUs
2. All ROs
3. All CGMs at HQ
4. All GMs at HQ
5. CVO, NHAI

  
(B.N.Sahay)  
General Manager (CMC)

Copy for information to:

1. PS to Chairman
2. All PS to Members

**Integrity pact** *(Refer clause 29.19)*

Draft Integrity Pact Format applicable for works having value of Rs. 100 Cr and above

(Name of Project)

( \_\_\_\_\_ Division)

Tender No. \_\_\_\_\_

This Integrity Pact is made at \_\_\_\_\_ on this \_\_\_\_\_ day of \_\_\_\_\_ 2014

Between

National Highways Authority of India (NHA), a statutory body constituted under the National Highways Authority of India Act, 1988, which has been entrusted with the responsibility of development, maintenance and management of National Highways, having its office at G-5 & 6, Sector-10, Dwarka, New Delhi, hereinafter referred to as "The Principal", which expression shall unless repugnant to the meaning or contract thereof include its successors and permitted assigns.

and

\_\_\_\_\_, hereinafter referred to as "The Bidder/ Contractor/ Concessionaire/ Consultant" and which expression shall unless repugnant to be meaning or context thereof include its successors and permitted assigns.

**Preamble**

Whereas, the Principal intends to award, under laid down organizational procedures contract/s for ..... The Principal values full compliance with all relevant laws of the land, rules of land, regulations, economic use of resources and of fairness/ transparency in its relations with its Bidder(s) and /or Contractor(s)/Concessionaire(s)/Consultant(s).

And whereas in order to achieve these goals, the Principal will appoint an independent external Monitor (IEM), who will monitor the tender process and the execution of the contract for compliance with the Principles mentioned above.

And whereas to meet the purpose aforesaid, both the parties have agreed to enter into this Integrity Pact (hereafter referred to as Integrity Pact) the terms and conditions of which shall also be read as integral part and parcel of the Tender documents and contract between the parties. Now, therefore, in consideration of mutual covenants stipulated in this pact, the parties hereby agree as follows and this pact witnesseth as under:-

**Article-1-Commitments of the Principal**

- (1) The Principal commits itself to take all measures necessary to prevent corruption and to observe the following principle:-
- (a) No employee of the Principal, personally or through family members, will in connection with the tender for, or the execution of a contract, demand, take a promise for or accept, for self or third person, any material or immaterial benefit which the person is not legally entitled to.
  - (b) The Principal will, during the tender process treat all Bidder(s) with equity and reason. The Principal will in particular, before and during the tender process, provide to all Bidder(s) the same information and will not provide to any Bidder(s) confidential/ additional information through which the Bidder(s) could obtain an advantage in relation to the tender process or the contract execution.
  - (c) The Principal will exclude all known prejudiced persons from the process, whose conduct in the past has been of biased nature.
- (2) If the Principal obtains information on the conduct of any of its employees which is a criminal offence under the IPC/PC Act or any other Statutory Acts or if there be a substantive suspicion in this regard, the Principal will inform the Chief Vigilance Officer and in addition can initiate disciplinary actions as per its internal laid down Rules/ Regulations.

**Article-2 Commitments of the Bidder(s)/ Contractor(s)/ Concessionaire(s)/ Consultant(s)**

The Bidder(s)/ Contractor(s)/ Concessionaire(s)/ Consultant(s) commit himself to take all measures necessary to prevent corruption. He commits himself to observe the following principles during his participation in the tender process and during the contract execution.

- (a) The Bidder(s)/ Contractor(s)/ Concessionaire(s)/ Consultant(s) will not, directly or through any other person or firm, offer, promise or give to any of the Principal's employees involved in the tender process or the execution of the contract or to any third person any material or other benefit which he/she is not legally entitled to, in order to obtain in exchange any advantage of any kind whatsoever during the tender process or during the execution of the contract.
- (b) The Bidder(s)/ Contractor(s)/ Concessionaire(s)/ Consultant(s) will not enter with other Bidders into any undisclosed agreement or understanding, whether formal or informal. This applies in particular to prices, specifications, certifications, subsidiary contracts, submission or non-submission or bids or

any other actions to restrict competitiveness or to introduce cartelization in the bidding process.

- (c) The Bidder(s)/ Contractor(s)/ Concessionaire(s)/ Consultant(s) will not commit any offence under the relevant IPC / PC Act and other Statutory Acts; further the Bidder(s)/ Contractor(s)/ Concessionaire(s)/ Consultant(s) will not use improperly, for purposes of completion or personal gain, or pass on to others, any information or document provided by the Principal as part of the business relationship, regarding plans, technical proposals and business details, including information contained or transmitted electronically.
- (d) The Bidder(s)/ Contractor(s)/ Concessionaire(s)/ Consultant(s) of foreign origin shall disclose the name and address of the Agents/ representatives in India, if any. Similarly the Bidder(s)/ Contractor(s)/ Concessionaire(s)/ Consultant(s) of Indian Nationality shall furnish the name and address of the foreign principle, if any.
- (e) The Bidder(s)/ Contractor(s)/ Concessionaire(s)/ Consultant(s) will, when presenting his bid, disclose any and all payments he has made, is committed to or intends to make to agents, brokers or any other intermediaries in connection with the award of the contract. He shall also disclose the details of services agreed upon for such payments.
- (f) The Bidder(s)/ Contractor(s)/ Concessionaire(s)/ Consultant(s) will not instigate third persons to commit offences outlined above or be an accessory to such offences.
- (g) The Bidder(s)/ Contractor(s)/ Concessionaire(s)/ Consultant(s) will not bring any outside influence through any Govt. bodies/quarters directly or indirectly on the bidding process in furtherance of his bid.

**Article 3 Disqualification from tender process and exclusion from future contracts**

- (1) If the Bidder(s)/ Contractor(s)/ Concessionaire(s)/ Consultant(s), before award or during execution has committed a transgression through a violation of any provision of Article-2, above or in any other form such as to put his reliability or credibility in question, the Principal is entitled to disqualify the Bidder(s)/ Contractor(s)/ Concessionaire(s)/ Consultant(s) from the tender process.
- (2) If the Bidder/Contractor/Concessionaire/Consultant has committed a transgression through a violation of Article-2 such as to put his reliability or

credibility into question, the Principal shall be entitled to exclude including blacklist and put on holiday the Bidder/Contractor/Concessionaire/Consultant for any future tenders/contract award process. The imposition and duration of the exclusion will be determined by the severity of the transgression. The severity will be determined by the Principal taking into consideration the full facts and circumstances of each case particularly taking into account the number of transgressions, the position of the transgressors within the company hierarchy or the Bidder/Contractor/Concessionaire/Consultant and the amount of the damage. The exclusion will be imposed for a minimum of 1 year.

- (3) A transgression is considered to have occurred if the Principal after due consideration of the available evidence concludes that "On the basis of facts available there are no material doubts".
- (4) The Bidder/ Contractor/Concessionaire/Consultant will its free consent and without any influence agrees and undertakes to respect and uphold the Principal's absolute rights to resort to and impose such exclusion and further accepts and undertakes not to challenge or question such exclusion on any ground, including the lack of any hearing before the decision to resort to such exclusion is taken. This undertaking is given freely and after obtaining independent legal advice.
- (5) The decision of the Principal to the effect that a breach of the provisions of this Integrity Pact has been committed by the Bidder/ Contractor/Concessionaire/Consultant shall be final and binding on the Bidder/ Contractor/Concessionaire/Consultant, however, the Bidder/Contractor/Concessionaire/Consultant can approach IEM(s) appointed for the purposes of this pact..
- (6) On occurrence of any sanctions/ disqualification etc. arising out from violation of integrity pact, Bidder/ Contractor/Concessionaire/Consultant shall not be entitled for any compensation on this account.
- (7) Subject to full satisfaction of the Principal, the exclusion of the Bidder/Contractor/Concessionaire/Consultant could be revoked by the Principal if the Bidder/ Contractor/Concessionaire/Consultant can prove that he has restored/recouped the damage caused by him and has installed a suitable corruption prevention system in his organization.

#### Article 4 Compensation for Damages

- (1) If the Principal has disqualified the Bidder(s) from the tender process prior to the award according to Article 3, the Principal shall be entitled to forfeit the Earnest Money Deposit/Bid Security or demand and recover the damages

equivalent to Earnest Money Deposit/Bid Security apart from any other legal right that may have accrued to the Principal.

- (2) In addition to above, the Principal shall be entitled to take recourse to the relevant provisions of the contract related to Termination of Contract due to Contractor/Concessionaire/Consultant's Default. In such case, the Principal shall be entitled to forfeit the Performance Bank Guarantee of the Contractor/Concessionaire/Consultant and/or demand and recover liquidated and all damages as per the provisions of the contract/Concession agreement against Termination.

#### Article 5 Previous Transgressions

- (1) The Bidder declares that no previous transgression occurred in the last 3 years immediately before signing of this integrity pact with any other Company in any country conforming to the anti corruption/Transparency International (TI) approach or with any other Public Sector Enterprise/Undertaking in India or any Government Department in India that could justify his exclusion from the tender process.
- (2) If the Bidder makes incorrect statement on this subject, he can be disqualified from the tender process or action for his exclusion can be taken as mentioned under Article-3 above for transgression of Article-2 and shall be liable for compensation for damages as per Article-4 above.

#### Article 6 Equal treatment of all Bidders/ Contractors/ Concessionaires/ Consultants/ Subcontractors

- (1) The Bidder(s) / Contractor(s) / Concessionaire (s) / Consultant (s) undertake(s) to demand from all sub-contractors a commitment in conformity with this Integrity Pact, and to submit it to the Principal before contract signing.
- (2) The Principal will enter into agreements with identical conditions as this one with all Bidders/Contractors/Concessionaire/Consultant and Subcontractors.
- (3) The Principal will disqualify from the tender process all Bidders who do not sign this Pact or violate its provisions.

#### Article 7 Criminal charges against violating Bidder(s)/ Contractor(s)/ Concessionaire(s)/ Consultant(s)/ Sub-contractor(s)

If the Principal obtains knowledge of conduct of a Bidder/Contractor/ Concessionaire/Consultant or Subcontractor, or of an employee or a representative or an associate of a Bidder/Contractor/ Concessionaire/Consultant or Subcontractor, which constitutes corruption, or if

the Principal has substantive suspicion in this regard, the Principal will inform the same to the Chief Vigilance Officer.

**Article 8 Independent External Monitor (IEM)**

- 1) The Principal appoints competent and credible independent external monitor for this pact. The task of the monitor is to review independently and objectively, whether and to what extent the parties comply with obligation under this agreement.
- 2) The Monitor is not subject to instructions by the representatives of the parties and performs his functions neutrally and independently. He reports to the Chairman, NHAI.
- 3) The Bidder/ Contractor/ Concessionaire/ Consultant accepts that the Monitor has the right to access without restriction to all project documentation of the Principal including that provided by the Bidder/ Contractor/ Concessionaire/ Consultant. The Bidder/ Contractor/ Concessionaire/ Consultant will also grant the Monitor, upon his request and demonstration of a valid interest, unrestricted and unconditional access to his project. The Monitor is under contractual obligation to treat the information and documents of the Bidder/ Contractor/ Concessionaire/ Consultant/ Sub- Contractor with confidentiality.
- 4) The Principal will provide to the Monitor sufficient information about all meetings among the parties related to the Project provided such meetings could have an impact on the contractual relation between the principal and the Bidder/ Contractor/ Concessionaire/ Consultant. The Parties offer to the Monitor the option to participate in such meetings.
- 5) As soon as the Monitor notices or believes to notice any transgression as given in Article 2, he may request the Management of the Principal to take corrective action, or to take relevant action. The Monitor can in this regard submit non binding recommendations. Beyond this the Monitor has no right to demand from the parties that they act in a specific manner, refrain from action or tolerate action.
- 6) The Monitor will submit a written report to the Chairman, NHAI within 8-10 weeks from the date of reference or intimation to him by the Principal and, should the occasion arise, submit proposals for correcting problematic situations.
- 7) If the Monitor has reported to the Chairman, NHAI, a substantiated suspicion of under relevant IPC/PC Act or any other Statutory Acts, and the Chairman, NHAI has not, within the reasonable time taken visible action to proceed against such offence or reported it the Chief Vigilance Officer, the Monitor may also transmit this information directly to the Central Vigilance Commissioner.
- 8) The Word "**Monitor**" would include both singular and plural.

**Article 9 Pact Duration**

This Pact begins when both parties have Legally signed it. [In case of EPC i.e. for projects funded by Principal and consultancy services] It expires for the Contractor/Consultant 12 months after his Defect Liability Period is over or 12 months after his last payment under the contract whichever is later and for all other *unsuccessful* Bidders 6 months after his Contract has been awarded. [In case of BOT projects] It expires for the concessionaire 24 months after his concession period is over and for all other unsuccessful Bidders 6 months after this Contract has been awarded.

If any claim is made/lodged during this time, the same shall be biding and continue to be valid despite the lapse of this pact as specified above, unless it is discharged /determined by Chairman of NHAI.

**Article 10 Other Provisions**

- (1) This pact is subject to Indian Law, Place of performance and jurisdiction is the Registered Office of the Principal, i.e. New Delhi.
- (2) Changes and supplements as well as termination notices need to be made in writing.
- (3) If the Bidder/Contractor/Concessionaire/Consultant is a partnership or a consortium, this pact must be signed by all partners or consortium members.
- (4) Should one or several provisions of this agreement turn out to be invalid, the reminder of this agreement remains valid. In this case, the parties will strive to come to an agreement to their original intentions.
- (5) Any dispute/differences arising between the parties with regard to term of this Pact, any action taken by the Principal in accordance with this Pact or interpretation thereof shall not be subject to any Arbitration.
- (6) The actions stipulated in the integrity Pact are without prejudice to any other legal action that may follow in accordance with the provisions of the extant law in force relating to any civil or criminal proceedings.

In witness whereof the parties have signed and executed this pact at the place and date first done mentioned in the presence of following witnesses:-

\_\_\_\_\_  
(For & On behalf of the (Principal)

(Office Seal)

\_\_\_\_\_  
(For & On behalf of Bidder/

Contractor/Concessionaire/Consultant

Place \_\_\_\_\_

Date \_\_\_\_\_

Witness 1:

(Name & Address)

\_\_\_\_\_  
\_\_\_\_\_  
\_\_\_\_\_

Witness 2:

(Name & Address)

\_\_\_\_\_  
\_\_\_\_\_  
\_\_\_\_\_

**APPENDIX B-9: DRAFT INTEGRITY PACT**

*(To be executed on plain paper and submitted along with Technical Bid/Tender documents for tenders having a value between Rs.5 Cr and Rs.100 Cr. To be signed by the bidder and same signatory competent/ authorized to sign the relevant contract on behalf of the NHAI)*

Tender No. \_\_\_\_\_

This integrity Pact is made at \_\_\_\_\_ on this \_\_\_\_\_ day of \_\_\_\_\_ 2016.

Between

National Highways Authority of India (NHAI), a statutory body constituted under the National Highways Authority of India Act, 1988, which has been entrusted with the responsibility of development, maintenance and management of National Highways, having its office at Plot No. 3, Surya Towers, 2<sup>nd</sup> Floor, 1<sup>st</sup> East Street, K.K. Nagar, Madurai - 625 020, hereinafter referred to as “The Principal”, which expression shall unless repugnant to the meaning or contract thereof include its successors and permitted assigns.

and

\_\_\_\_\_ hereinafter referred to as “The Bidder / Contractor / Concessionaire / Consultant” and which expression shall unless repugnant to be meaning or context thereof include its successors and permitted assigns.

**Preamble**

Whereas, the Principal intends to award, under laid down organizational procedures, contract/s for “Supervision Consultant services during Operation & Maintenance Period for Operation & Maintenance of 4 laning of Madurai - Tirunelveli - Panagudi - Kanniyakumari Section from Km 0/000 to Km 243/170 of NH-7 (New NH.44) including construction of Bridge at Narikulam Tank Portion at km 230/700 to Km 231/250 and Improvement of Approach Road to ROB at Km 0/600 at Samayanallur of NH-7(New NH.44) and Operation & Maintenance of Tuticorin - Tirunelveli Section from Km 0/000 to km 47/250 of NH-7A (New NH.138) in the State of Tamil Nadu”. The Principal values full compliance with all relevant laws of the land, rules of land, regulations, economic use of resources and of fairness/transparency in its relations with its Bidder(s) and/ or Contractor(s)/Concessionaire(s)/Consultant(s).

And whereas to meet the purpose aforesaid, both the parties have agreed to enter into this Integrity Pact (hereafter referred to as Integrity Pact) the terms and conditions of which shall also be read as integral part and parcel of the Tender documents and contract between the parties. Now, therefore, in consideration of mutual covenants stipulated in this pact, the parties hereby agree as follows and this pact witnesseth as under:-

**Article 1 Commitments of the Principal**

1. The Principal commits itself to take all measures necessary to prevent corruption and to observe the following principles:-

- (a) No employee of the Principal, personally or through family members, will in connection with the tender for, or the execution of a contract, demand, take a promise for or accept, for self, or third person, any material or immaterial benefit which the person is not legally entitled to.
  - (b) The Principal will, during the tender process treat all Bidder(s) with equity and reason. The Principal will in particular, before and during the tender process, provide to all Bidder(s) the same information and will not provide to any Bidder(s) confidential/ additional information through which the Bidder(s) could obtain an advantage in relation to the tender process or the contract execution.
  - (c) The Principal will exclude all known prejudiced persons from the process, whose conduct in the past has been of biased nature.
2. If the Principal obtains information on the conduct of any of its employees which is a criminal offence under the IPC/PC Act or any other Statutory Acts or if there be a substantive suspicion in this regard, the Principal will inform the Chief Vigilance Officer and in addition can initiate disciplinary actions as per its internal laid down Rules/Regulations.

#### **Article 2 Commitments of the Bidder(s) / Contractor(s) / Concessionaire(s) / Consultant(s).**

The Bidder(s) / Contractor(s) / Concessionaire(s) / Consultant(s) commit himself to take all measures necessary to prevent corruption. He commits himself to observe the following principles during his participation in the tender process and during the contract execution.

- (a) The Bidder(s) / Contractor(s) / Concessionaire(s) / Consultant(s) will not, directly or through any other person or firm, offer, promise or give to any of the Principal's employees involved in the tender process or the execution of the contract or to any third person any material or other benefit which he/she is not legally entitled to, in order to obtain in exchange any advantage of any kind whatsoever during the tender process or during the execution of the contract.
- (b) The Bidder(s) / Contractor(s) / Concessionaire(s) / Consultant(s) will not enter with other Bidders into any undisclosed agreement or understanding, whether formal or informal. This applies in particular to prices, specifications, certifications, subsidiary contracts, submission or non-submission of bids or any other actions to restrict competitiveness or to introduce cartelization in the bidding process.
- (c) The Bidder(s) / Contractor(s) / Concessionaire(s) / Consultant(s) will not commit any offence under the relevant IPC/PC Act and other Statutory Acts; further the Bidder(s) / Contractor(s) / Concessionaire(s) / Consultant(s) will not use improperly, for purposes of completion or personal gain, or pass on to others, any information or document provided by the Principal as part of the

business relationship, regarding plans, technical proposals and business details, including information contained or transmitted electronically.

- (d) The Bidder(s) / Contractor(s) / Concessionaire(s) / Consultant(s) of foreign-origin shall disclose the name and address of the Agents/ Representatives in India, if any. Similarly the Bidder(s) / Contractor(s) / Concessionaire(s) / Consultant(s) of Indian Nationality shall furnish the name and address of the foreign principle, if any.
- (e) The Bidder(s) / Contractor(s) / Concessionaire(s) / Consultant(s) will, when presenting his bid, disclose any and all payments he has made, is committed to or intends to make to agents, brokers or any other intermediaries in connection with the award of the contract. He shall also disclose the details of services agreed upon for such payments.
- (f) The Bidder(s) / Contractor(s) / Concessionaire(s) / Consultant(s) will not instigate third persons to commit offences outlined above or be an accessory to such offences.
- (g) The Bidder(s) / Contractor(s) / Concessionaire(s) / Consultant(s) will not bring any outside influence through any Govt. bodies/quarters directly or indirectly on the bidding process in furtherance of his bid.

### **Article 3 Disqualification from tender process and exclusion from future contracts.**

1. If the Bidder(s) / Contractor(s) / Concessionaire(s) / Consultant(s), before award or during execution has committed a transgression through a violation of any provision of Article-2, above or in any other form such as to put his reliability or credibility in question, the Principal is entitled to disqualify the Bidder(s) / Contractor(s) / Concessionaire(s) / Consultant(s) from the tender process.
2. If the Bidder / Contractor / Concessionaire / Consultant has committed a transgression through a violation of Article-2 such as to put his reliability or credibility into question, the Principal shall be entitled to exclude including blacklist and put on holiday the Bidder / Contractor / Concessionaire / Consultant for any future tenders/ contract award process. The imposition and duration of the exclusion will be determined by the severity of the transgression. The severity will be determined by the Principal taking into consideration the full facts and circumstances of each case particularly taking into account the number of transgressions, the position of the transgressors within the company hierarchy of the Bidder / Contractor / Concessionaire / Consultant and the amount of the damage. The exclusion will be imposed for a minimum of 1 year.
3. A transgression is considered to have occurred if the Principal after due consideration of the available evidence concludes that “On the basis of facts available there are no material doubts”.

4. The Bidder / Contractor / Concessionaire / Consultant with its free consent and without any influence agrees and undertakes to respect and uphold the Principal's absolute rights to resort to and impose such exclusion and further accepts and undertakes not to challenge or question such exclusion on any ground, including the lack of any hearing before the decision to resort to such exclusion is taken. This undertaking is given freely and after obtaining independent legal advice.
5. The decision of the Principal to the effect that a breach of the provisions of this Integrity Pact has been committed by the Bidder / Contractor / Concessionaire / Consultant shall be final and binding on the Bidder / Contractor / Concessionaire / Consultant.
6. On occurrence of any sanctions / disqualification etc arising out from violation of integrity pact, the Bidder / Contractor / Concessionaire / Consultant shall not be entitled for any compensation on this account.
7. Subject to full satisfaction of the Principal, the exclusion of the Bidder / Contractor / Concessionaire / Consultant could be revoked by the Principal if the Bidder / Contractor / Concessionaire / Consultant can prove that he has restored/ recouped the damage caused by him and has installed a suitable corruption prevention system in his organization.

#### **Article 4 Compensation for Damages.**

1. If the Principal has disqualified the Bidder(s) from the tender process prior to the award according to Article-3, the Principal shall be entitled to forfeit the Earnest Money Deposit / Bid Security or demand and recover the damages equivalent to Earnest Money Deposit / Bid Security apart from any other legal right that may have accrued to the Principal.
2. In addition to 1 above, the Principal shall be entitled to take recourse to the relevant provisions of the contract related to Termination of Contract due to Contractor / Concessionaire / Consultant's Default. In such case, the Principal shall be entitled to forfeit the Performance Bank Guarantee of the Contractor / Concessionaire / Consultant and / or demand and recover liquidated and all damages as per the provisions of the contract/concession agreement against Termination.

#### **Article 5 Previous Transgression**

1. The Bidder declares that no previous transgressions occurred in the last 3 years immediately before signing of this Integrity Pact with any other Company in any country conforming to the anti corruption / Transparency International (TI) approach or with any other Public Sector Enterprise / Undertaking in India or any Government Department in India that could justify his exclusion from the tender process.
2. If the Bidder makes incorrect statement on this subject, he can be disqualified from the tender process or action for his exclusion can be taken as mentioned under Article-

3 above for transgressions of Article-2 and shall be liable for compensation for damages as per Article-4 above.

**Article 6 Equal treatments of all Bidders / Contractors / Concessionaires / Consultants / Subcontractors.**

1. The Bidder(s) / Contractor(s) / Concessionaire(s) / Consultant(s) undertake(s) to demand from all sub-contractors a commitment in conformity with this Integrity Pact, and to submit it to the Principal before contract signing.
2. The Principal will enter into agreements with identical conditions as this one with all Bidders / Contractors / Concessionaires / Consultants and Subcontractors.
3. The Principal will disqualify from the tender process all Bidders who do not sign this Pact or violate its provisions.

**Article 7 Criminal charges against violating Bidder(s) / Contractor(s) / Concessionaire(s) / Consultant(s) / Sub-contractor(s).**

If the Principal obtains knowledge of conduct of a Bidder / Contractor / Concessionaire / Consultant or Subcontractor, or of an employee or a representative or an associate of a Bidder / Contractor / Concessionaire / Consultant or Subcontractor, which constitutes corruption, or if the Principal has substantive suspicion in this regard, the Principal will inform the same to the Chief Vigilance Officer.

**Article 8 Pact Duration**

This Pact begins when both parties have legally signed it. (In case of EPC i.e. for projects funded by Principal and consultancy services). It expires for the Contractor / Consultant 12 months after his Defect Liability period is over or 12 months after his last payment under the contract whichever is later and for all other unsuccessful Bidders 6 months after this Contract has been awarded. (In case of BOT / DBFOT/OMT Projects) It expires for the concessionaire 24 months after his concession period is over and for all other unsuccessful Bidders 6 months after this Contract has been awarded. If any claim is made / lodged during this time, the same shall be binding and continue to be valid despite the lapse of this pact as specified above, unless it is discharged / determined by Chairman of NHAI.

**Article 9 Other Provisions.**

1. This pact is subject to Indian Law. Place of performance and jurisdiction is the Registered Office of the Principal, i.e. Chennai.
2. Changes and supplements as well as termination notices need to be made in writing.
3. If the Bidder / Contractor / Concessionaire / Consultant is a partnership or a consortium, this pact must be signed by all partners or consortium members.

4. Should one or several provisions of this agreement turn out to be invalid, the remainder of this agreement remains valid. In this case, the parties will strive to come to an agreement to their original intentions.
5. Any disputes / differences arising between the parties with regard to term of this pact, any action taken by the Principal in accordance with this Pact or interpretation thereof shall not be subject to any Arbitration.
6. The actions stipulated in this Integrity Pact are without prejudice to any other legal action that may follow in accordance with the provisions of the extant law in force relating to any civil or criminal proceedings.

In witness whereof the parties have signed and executed this Pact at the place and date first done mentioned in the presence of following witness:-

\_\_\_\_\_  
(For & On behalf of the Principal) (For & On behalf of the Bidder / Contractor /  
Concessionaire / Consultant)

(Office Seal)

Place: \_\_\_\_\_

Date: \_\_\_\_\_

**Witness 1:** (Name & Address): \_\_\_\_\_

**Witness 2:** (Name & Address): \_\_\_\_\_